

Design No. HI/BPF 120-14
PERIMETER FIRE BARRIER SYSTEM
Firestop Joint Spray CFS-SP WB
ASTM E 2307, UL 2079 (Air Leakage)

HI/BPF 120-14

Table 1

	FIRESTOP JOINT SPRAY CFS-SP WB	SILICONE JOINT SPRAY CFS-SP SIL
F-RATING	2-HR.	2-HR.
T-RATING	45 MINUTE	45 MINUTE
L-Rating	< 1.0 SCFM/LF	< 1.0 SCFM/LF
APPLICATION THICKNESS	1/8 IN. WET FILM (1/16 IN. DRY)	2 MM (0.08 IN.) WET FILM
CYCLING (%) HORIZONTAL VERTICAL	$\pm 12.5\%$ $\pm 12.5\%$	$\pm 12.5\%$ $\pm 12.5\%$

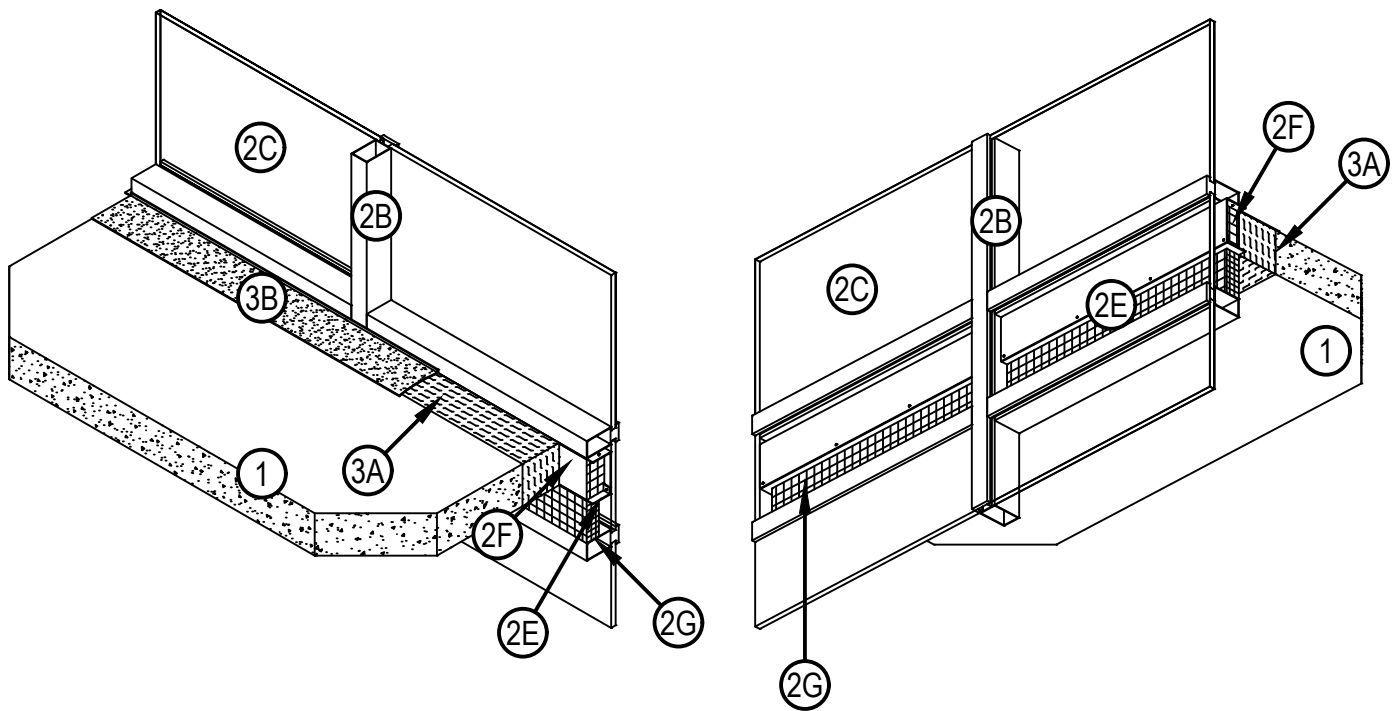

1. CONCRETE FLOOR ASSEMBLY: 2 hour rated concrete floor assembly made from either lightweight or normal weight concrete with a density of 100 to 150 pcf, having a min. thickness of 6 in. at the joint face. When a longitudinal recess (blockout) is required to contain an architectural joint system, increase concrete floor assembly thickness to maintain a min. thickness of 6 in. and accommodate depth of blockout formed in the concrete: blockout width unrestricted.
2. CURTAIN WALL ASSEMBLY: The curtain wall assembly shall incorporate the following construction features:
 - A. Mounting Attachment (Not Shown) - Attach aluminum framing (Item 2B) to the structural framing according to the curtain wall manufacturer's instructions. Connect the mounting attachments to the joint face of the concrete floor assembly (Item 1) according to the curtain wall manufacturer's instructions.
 - B. Aluminum Framing - Use hollow rectangular aluminum extruded tubing with min. overall dimensions of 0.100 in. thick, 4 in. high and 2-1/2 in. wide. Locate mullions (vertical aluminum framing) min. 60 in. on center (oc). Locate the upper transom (horizontal aluminum framing) such that the bottom surface of the transom is at the same height as the top surface of the floor assembly. For the spandrel region, the lower transom (horizontal aluminum framing) must be spaced a min. of 6 in. below the concrete floor as measured from the underside of the floor to the top side of the transom.
 - C. Glass Panels - Sized and installed into aluminum framing (Item 2B) in accordance with the curtain wall manufacturer's instructions. Use min. 1/4 in. thick, clear, heat strengthened (HS) or tempered glass with a max. width and height less than the aluminum framing (Item 2B) oc spacing. OC spacing shall allow glass to be secured to the aluminum framing (Item 2B) between the notched shoulders. Secure glass panels with a thermal break (rubber extrusion), pressure bar (aluminum extrusion), min. 1/4-20 x 5/8 in. long screws, and a snap face (aluminum extrusion).
 - D. Aluminum Anchor Brackets (Not Shown) - Use min. 1/2 in. thick aluminum anchor brackets to serve as part of the mounting attachment (Item 2A) rigidly secured to the aluminum framing (Item 2B) and the concrete floor assembly (Item 1).
 - E. Sheet Metal Pan - Attach a fabricated 18 GA galvanized or plain steel box pan, 6 in. high and 3 in. deep composed of two L-shaped sections, to the aluminum framing with No. 10 self-drilling sheet metal screws at 12 in. oc along the top, and with four No. 10 self-drilling sheet metal screws at each vertical end (two installed at the top and two at the bottom). Install a bead of Hilti CFS-S SIL GG Firestop Silicone on the underside of the horizontal member prior to installation of the 3 in. x 6 in. 18 GA steel box pan. This box pan shall create a cavity that is 3 in. deep and 6 in. tall underneath the aluminum member to house the curtain wall insulation (Item 2F). The box may be fabricated by either method below:
 - a. An 18 GA galvanized or plain steel angle is attached to the underside of the aluminum framing. The angle shall be formed such that it has a 3 in. leg and a 6 in. leg, with the 3 in. leg attached to the aluminum framing. A second 1 in. x 3 in. 18 GA galvanized or plain steel angle is attached to the first with the 1 in. leg secured to the 6 in. leg of the first angle with No. 10 self-drilling sheet metal screws, spaced 12 in. oc. The 3 in. portion of the 3 in. x 1 in. angle is to be sized such that a 6 in. leg can be bent and formed into a vertical leg at the ends to secure the angle to the vertical framing members on each side.
 - b. (Not Whown) An 18 GA galvanized or plain steel angle is attached to the underside of the aluminum framing. The angle shall be formed such that it has a 3 in. leg and a 1 in. leg, with the 3 in. leg attached to the aluminum framing. The 3 in. portion of the 3 in. x 1 in. angle is to be sized such that a 7 in. leg can be bent and formed into a 6 in. vertical leg, to secure the angle to the vertical framing members on each side, with a 1 in. horizontal flange at the bottom ends. A second 6 in. x 3 in. 18 GA galvanized or plain steel angle is attached to the first with the 6 in. leg secured to the 1 in. leg of the first angle with No. 10 self-drilling sheet metal screws, spaced 12 in. oc along the 1 in. leg and with at least one No. 10 self-drilling sheet metal screw at each end, secured to the 1 in. flange on the vertical legs of the first angle.
 - D. CERTIFIED MANUFACTURER: Thermafiber, Inc.
CERTIFIED PRODUCT: FireSpan® 90
Curtain Wall Insulation - Fill the cavity of the metal pan (Item 2E) with nominal 3 in. thick, min. 6 in. tall, 8 pcf density, mineral wool batt insulation. Tightly fit, compress at least 1/8 in. in all directions.
 - E. CERTIFIED MANUFACTURER: Thermafiber, Inc.
CERTIFIED PRODUCT: FireSpan® 90
CURTAIN WALL INSULATION - Friction fit nominal 2 or 3 in. thick, 8 pcf density, mineral wool batt insulation in the area below the sheet metal pan flush with the front surface of the mullions. Tape all adjacent edges between curtain wall insulation, or between aluminum framing (Item 2B) and curtain wall insulation, with pressure sensitive aluminum foil tape, centered over the seam.

3. PERIMETER JOINT PROTECTION: Do not exceed a 4 in. nominal joint width (joint width at installation). Incorporate the following construction features for the perimeter joint protection (also known as perimeter fire barrier system):

A. CERTIFIED MANUFACTURER: Thermafiber, Inc.

CERTIFIED PRODUCT: Safing

Packing Material - Use min. 6 in. tall, 4 pcf density, mineral wool batt insulation and cut packing material width to achieve 25% compression when installed in the nominal joint width, and use no more than two adjacent strips. Install insulation with the fibers running parallel to the edge of concrete floor assembly (Item 1) and curtain wall assembly (Item 2A). Tightly compress together splices (butt joints) in the lengths of packing material by using min. 1/4 in. compression per piece of packing material. Locate the top surface of the packing material flush with the top surface of the concrete floor assembly (Item 1).

B. CERTIFIED MANUFACTURER: Hilti Corporation

CERTIFIED PRODUCT: Firestop Joint Spray CFS-SP WB or Silicone Joint Spray CFS-SP SIL

Fill, Void, or Cavity Material - Apply over the packing material (Item 3A) as follows:

Apply at the thickness specified in Table 1 and overlap the material 1/2 in. onto the adjacent curtain wall assembly and concrete floor slab assembly. When the spraying process is stopped and the applied liquid cures to an elastomeric film before application is restarted, overlap the edge of the cured material at least 1/8 in. with the spray. Reference Product Section of the Intertek Directory for more details on the Listed product.



Hilti Firestop Systems

Reproduced by HILTI, Inc.
Courtesy of Intertek Group
December 21, 2018

Intertek