



The following excerpt are pages from the North American Product Technical Guide, Volume 2: Anchor Fastening, Edition 22.

Please refer to the publication in its entirety for complete details on this product including data development, product specifications, general suitability, installation, corrosion and spacing and edge distance guidelines.

US&CA: <https://submittals.us.hilti.com/PTGVol2/>





To consult directly with a team member regarding our anchor fastening products, contact Hilti's team of technical support specialists between the hours of 7:00am – 6:00pm CST.

US: 877-749-6337 or HNATechnicalServices@hilti.com

CA: 1-800-363-4458, ext. 6 or CATechnicalServices@hilti.com

3.3.2 HSL4 HEAVY-DUTY EXPANSION ANCHORS

PRODUCT DESCRIPTION

Anchor system				Features and benefits
HSL4 Heavy-duty Expansion Anchor	HSL4-B Heavy-duty Expansion Anchor with Torque Cap	HSL4-G Heavy-duty Expansion Anchor with Threaded Rod	HSL4-SK Countersunk version available as special	<ul style="list-style-type: none"> • Approved for use in the concrete tension zone (cracked concrete) • Approved for use with cored drilled holes using the Hilti diamond coring tool, DD-30 or DD-EC-1 with the SPX-T core bits or with the Hilti Diamond Coring Tool DD-110 to DD-250 with the SPPX-H, SPX-L or SPX-L Handheld core bits • Data for use with the Strength Design provisions of ACI 318 Chapter 17 and ACI 349 Appendix B • High load capacity • Force-controlled expansion which allows for follow-up expansion • Suitable for dynamic loading, including seismic¹, fatigue and shock • No spinning of the anchor in hole when tightening bolt or nut • Seismic qualification per ICC-ES AC193 and the requirements of ACI 318 Chapter 17
				

3.3.2

¹ HSL4-G M24 is not approved for seismic design.

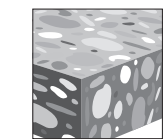

Uncracked concrete

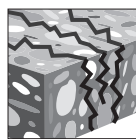

Cracked concrete

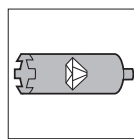

Diamond cored holes for cracked and uncracked concrete

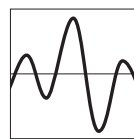

Seismic Design Categories A-F



Profis Anchor design software



Hollow Drill Bit

Approvals/Listings	
ICC-ES (International Code Council)	ESR-4386 in concrete per ACI 318 Ch. 17 / ACI 355.2/ ICC-ES AC193
European Technical Approval	ETA-19/0556
City of Los Angeles	2020 LABC Supplement (within ESR-4386)
Nuclear Quality Assurance	Qualified under NQA-1 Nuclear Quality Program



MATERIAL SPECIFICATIONS

Carbon steel bolt or threaded rod for HSL4, HSL4-G, HSL4-B and HSL4-SK conform to the steel strength requirements of ISO 898-1, grade 8.8, $f_{ya} > 93$ ksi, $f_{uta} > 116$ ksi.

Nut, washer, expansion cone, expansion sleeve and spacing sleeve are all made of carbon steel.

Collapsible sleeve is made from acetal polyoxymethylene (POM) resin and thermoplastic elastomer (TPE).

INSTALLATION PARAMETERS

Table 1 — HSL4 Specifications

Details			HSL4 anchor thread diameter													
			M8		M10		M12			M16			M20		M24	
Nominal drill bit diameter ¹	d_{bit}	mm	12		15		18			24			28		32	
Minimum concrete thickness	h_{min}	mm (in.)	See table 5													
Minimum hole depth	h_o	mm (in.)	80 (3-1/8)		90 (3-1/2)		105 (4-1/8)			125 (4-7/8)			155 (6-1/8)		180 (7-1/8)	
Effective minimum embedment	$h_{ef,min}$	mm (in.)	60 (2-3/8)		70 (2-3/4)		80 (3-1/8)			100 (3-7/8)			125 (4-7/8)		150 (5-7/8)	
Fixture hole diameter	d_h	mm (in.)	14 (9/16)		17 (11/16)		20 (13/16)			26 (1)			31 (1-1/4)		35 (1-3/8)	
Maximum thickness of part fastened HSL4, HSL4-B	t_{fix}	mm (in.)	20 (3/4)	40 (1-1/2)	20 (3/4)	40 (1-1/2)	5 (1/5)	25 (1)	50 (2)	10 (2/5)	25 (1)	50 (2)	30 (1-1/8)	60 (2-1/4)	30 (1-1/8)	60 (2-1/4)
Maximum thickness of part fastened HSL4-G	t_{fix}	mm (in.)	20 (3/4)		20 (3/4)	100 (4)	25 (1)	50 (2)	25 (1)	50 (2)	30 (1-1/8)	60 (2-1/4)	-	-	-	-
Washer diameter	d_w	mm (in.)	20 (3/4)		25 (1)		30 (1-1/8)			40 (1-9/16)			45 (1-3/4)		50 (2)	
Installation torque HSL4	T_{inst}	Nm (ft-lb)	15 (11)		25 (18)		60 (44)			75 (55)			145 (107)		210 (155)	
Installation torque HSL4-G	T_{inst}	Nm (ft-lb)	20 (15)		27 (20)		60 (44)			70 (52)			105 (77)		180 (132)	
Installation torque HSL4-SK	T_{inst}	Nm (ft-lb)	25 (18)		32 (24)		65 (48)			-			-		-	
Wrench size HSL4, HSL4-G	SW	mm	13		17		19			24			30		36	
Wrench size HSL4-B	SW	mm	-		-		24			30			36		41	
Wrench size HSL4-SK	SW	mm	5		6		8			-			-		-	
Diameter of countersunk hole HSL4-SK	d_{sk}	mm	22.5		25.5		32.9			-			-		-	

¹ Use metric bits only.

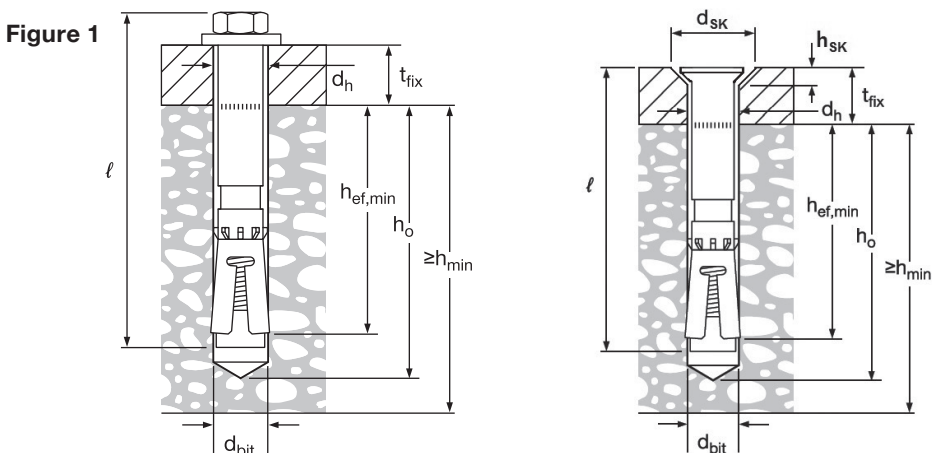

DESIGN DATA IN CONCRETE PER ACI 318

ACI 318 Chapter 17 Design

The load values contained in this section are Hilti Simplified Design Tables. The load tables in this section were developed using the Strength Design parameters and variables of ESR-4386 and the equations within ACI 318 Chapter 17. For a detailed explanation of the Hilti Simplified Design Tables, refer to section 3.1.8 of the North American Product Technical Guide, Volume 2: Anchor Fastening Technical Guide, Edition 22 (PTG Ed. 21). Data tables from ESR-4386 are not contained in this section but can be found at www.icc-es.org or at www.hilti.com.

Table 2 — Hilti HSL4 design strength with concrete / pullout failure in uncracked concrete^{1,2,3,4,5}

Nominal anchor diameter	Effective embed. mm (in.)	Tension - ϕN_n				Shear - ϕV_n			
		$f'_c = 2,500$ psi lb (kN)	$f'_c = 3,000$ psi lb (kN)	$f'_c = 4,000$ psi lb (kN)	$f'_c = 6,000$ psi lb (kN)	$f'_c = 2,500$ psi lb (kN)	$f'_c = 3,000$ psi lb (kN)	$f'_c = 4,000$ psi lb (kN)	$f'_c = 6,000$ psi lb (kN)
M8	60 (2.4)	2,735 (12.2)	2,995 (13.3)	3,455 (15.4)	4,235 (18.8)	3,050 (13.6)	3,340 (14.9)	3,860 (17.2)	4,725 (21.0)
M10	70 (2.8)	3,570 (15.9)	3,910 (17.4)	4,515 (20.1)	5,530 (24.6)	7,685 (34.2)	8,420 (37.5)	9,720 (43.2)	11,905 (53.0)
M12	80 (3.2)	4,360 (19.4)	4,775 (21.2)	5,515 (24.5)	6,755 (30.0)	9,390 (41.8)	10,285 (45.7)	11,880 (52.8)	14,550 (64.7)
M16	100 (3.9)	6,095 (27.1)	6,675 (29.7)	7,705 (34.3)	9,440 (42.0)	13,125 (58.4)	14,375 (63.9)	16,600 (73.8)	20,330 (90.4)
M20	125 (4.9)	8,515 (37.9)	9,330 (41.5)	10,770 (47.9)	13,190 (58.7)	18,340 (81.6)	20,090 (89.4)	23,200 (103.2)	28,415 (126.4)
M24	150 (5.9)	11,195 (49.8)	12,260 (54.5)	14,160 (63.0)	17,340 (77.1)	24,110 (107.2)	26,410 (117.5)	30,495 (135.6)	37,350 (166.1)

3.3.2

Table 3 — Hilti HSL4 design strength with concrete / pullout failure in cracked concrete^{1,2,3,4,5}

Nominal anchor diameter	Effective embed. mm (in.)	Tension - ϕN_n				Shear - ϕV_n			
		$f'_c = 2,500$ psi lb (kN)	$f'_c = 3,000$ psi lb (kN)	$f'_c = 4,000$ psi lb (kN)	$f'_c = 6,000$ psi lb (kN)	$f'_c = 2,500$ psi lb (kN)	$f'_c = 3,000$ psi lb (kN)	$f'_c = 4,000$ psi lb (kN)	$f'_c = 6,000$ psi lb (kN)
M8	60 (2.4)	1,825 (8.1)	2,000 (8.9)	2,310 (10.3)	2,830 (12.6)	2,160 (9.6)	2,365 (10.5)	2,730 (12.1)	3,345 (14.9)
M10	70 (2.8)	2,920 (13.0)	3,200 (14.2)	3,695 (16.4)	4,525 (20.1)	7,685 (34.2)	8,420 (37.5)	9,720 (43.2)	11,905 (53.0)
M12	80 (3.2)	4,360 (19.4)	4,775 (21.2)	5,515 (24.5)	6,755 (30.0)	9,390 (41.8)	10,285 (45.7)	11,880 (52.8)	14,550 (64.7)
M16	100 (3.9)	6,095 (27.1)	6,675 (29.7)	7,705 (34.3)	9,440 (42.0)	13,125 (58.4)	14,375 (63.9)	16,600 (73.8)	20,330 (90.4)
M20	125 (4.9)	8,515 (37.9)	9,330 (41.5)	10,770 (47.9)	13,190 (58.7)	18,340 (81.6)	20,090 (89.4)	23,200 (103.2)	28,415 (126.4)
M24 ⁵	150 (5.9)	11,195 (49.8)	12,260 (54.5)	14,160 (63.0)	17,340 (77.1)	24,110 (107.2)	26,410 (117.5)	30,495 (135.6)	37,350 (166.1)

1 See PTG Ed. 21 section 3.1.8 to convert design strength value to ASD value.

2 Linear interpolation between concrete compressive strengths is not permitted.

3 Apply spacing, edge distance, and concrete thickness factors in tables 5 to 8 as necessary. Compare to the steel values in table 4. The lesser of the values is to be used for the design.

4 Tabular values are for normal-weight concrete only. For lightweight concrete multiply design strength by λ_a as follows: for sand-lightweight, $\lambda_a = 0.68$; for all-lightweight, $\lambda_a = 0.60$.

5 Tabular values are for static loads only. Seismic design is not permitted for uncracked concrete. For all seismic tension loads for all other anchors, multiply cracked concrete tabular values in tension only by the following reduction factors:

M24 - $\alpha_{N,seis} = 0.62$. HSL4-G M24 is not approved for seismic design.All other sizes - $\alpha_{N,seis} = 0.75$

No reduction needed for seismic shear. See PTG Ed. 21 section 3.1.8 for additional information on seismic applications.

Table 4 – Steel strength for Hilti HSL4 anchors^{1,2}

Nominal anchor diameter	HSL4, HSL4-B, HSL4-SK			HSL4-G		
	Tensile ³ ϕN_{sa} lb (kN)	Shear ⁴ ϕV_{sa} lb (kN)	Seismic shear ⁵ $\phi V_{sa,eq}$ lb (kN)	Tensile ³ ϕN_{sa} lb (kN)	Shear ⁴ ϕV_{sa} lb (kN)	Seismic shear ⁵ $\phi V_{sa,eq}$ lb (kN)
M8	4,960 (22 .1)	4,705 (20 .9)	2,995 (13 .3)	4,960 (22 .1)	3,945 (17 .5)	2,455 (10 .9)
M10	7,830 (34 .8)	6,650 (29 .6)	5,495 (24 .4)	7,830 (34 .8)	5,450 (24 .2)	4,500 (20 .0)
M12	11,395 (50 .7)	9,570 (42 .6)	7,730 (34 .4)	11,395 (50 .7)	7,905 (35 .2)	6,385 (28 .4)
M16	21,140 (94 .0)	17,360 (77 .2)	16,115 (71 .7)	21,140 (94 .0)	14,745 (65 .6)	13,690 (60 .9)
M20	33,060 (147 .1)	25,690 (114 .3)	18,940 (84 .2)	33,060 (147 .1)	21,555 (95 .9)	15,900 (70 .7)
M24	47,590 (211 .7)	29,870 (132 .9)	24,810 (110 .4)	47,590 (211 .7)	28,060 (124 .8)	n/a

1 See PTG Ed. 21 section 3.1.8 to convert design strength value to ASD value.

2 Hilti HSL4 Carbon Steel anchors are to be considered ductile steel elements.

3 Tensile $\phi N_{sa} = \phi_{Asb} N_{f_{uta}}$ as noted in ACI 318 Chapter 17

4 Shear values determined by static shear tests with $\phi V_{sa} \leq \phi 0.60 A_{sa,V} f_{uta}$ as noted in ACI 318 Chapter 17

5 Seismic shear values determined by seismic shear tests with $\phi V_{sa,eq} \leq \phi 0.60 A_{sa,V} f_{uta}$ as noted in ACI 318 Chapter 17
See PTG Ed. 21 section 3.1.8 for additional information on seismic applications.

Table 5 – Edge distance, spacing and member thickness requirements¹

Condition	Dimensional parameter	Symbol	Units	Nominal anchor diameter						
				M8	M10	M12	M16	M20	M24	
A	Minimum concrete thickness	h_{min}	in. (mm)	4-3/4 (120)	5-1/2 (140)	6-1/4 (160)	7-7/8 (200)	9-7/8 (250)	11-7/8 (300)	
	Critical edge distance	c_{ac}	in. (mm)	4-3/8 (110)	4-3/8 (110)	4-3/4 (120)	5-7/8 (150)	8-7/8 (225)	8-7/8 (225)	
	Case 1	Minimum edge distance	$c_{min,1}$	in. (mm)	2-3/8 (60)	2-3/4 (70)	3-1/2 (90)	4-3/4 (120)	5 (125)	5-7/8 (150)
		Minimum anchor spacing	$s_{min,1}$	in. (mm)	5-1/2 (140)	9-1/2 (240)	11 (280)	12-5/8 (320)	13-3/4 (350)	11-7/8 (300)
	Case 2	Minimum edge distance	$c_{min,2}$	in. (mm)	3-3/8 (85)	5 (125)	6-1/8 (155)	7-7/8 (200)	8-1/4 (210)	8-1/4 (210)
		Minimum anchor spacing	$s_{min,2}$	in. (mm)	2-3/8 (60)	2-3/4 (70)	3-1/8 (80)	4 (100)	5 (125)	5-7/8 (150)
B	Minimum concrete thickness	h_{min}	in. (mm)	4-3/8 (110)	4-3/4 (120)	5-3/8 (135)	6-1/4 (160)	7-1/2 (190)	8-7/8 (225)	
	Critical edge distance	c_{ac}	in. (mm)	5-7/8 (150)	6-7/8 (175)	7-7/8 (200)	9-7/8 (250)	12-3/8 (312.5)	14-3/4 (375)	
	Case 1	Minimum edge distance	$c_{min,1}$	in. (mm)	2-3/8 (60)	3-1/2 (90)	4-3/8 (110)	6-1/4 (160)	7-7/8 (200)	8-7/8 (225)
		Minimum anchor spacing	$s_{min,1}$	in. (mm)	7 (180)	10-1/4 (260)	12-5/8 (320)	15 (380)	15-3/4 (400)	15 (380)
	Case 2	Minimum edge distance	$c_{min,2}$	in. (mm)	4 (100)	6-1/4 (160)	7-7/8 (200)	10-5/8 (270)	11-7/8 (300)	12-5/8 (320)
		Minimum anchor spacing	$s_{min,2}$	in. (mm)	2-3/8 (60)	2-3/4 (70)	3-1/8 (80)	4 (100)	5 (125)	5-7/8 (150)

3.3.2

¹ Linear interpolation is permitted to establish an edge distance and spacing combination between Case 1 and Case 2. Linear interpolation for a specific edge distance c , where $c_{min,1} < c < c_{min,2}$ will determine the permissible spacing s as follows:

$$s \geq s_{min,2} + \frac{(s_{min,1} - s_{min,2})}{(c_{min,1} - c_{min,2})} (c - c_{min,2})$$

Figure 2

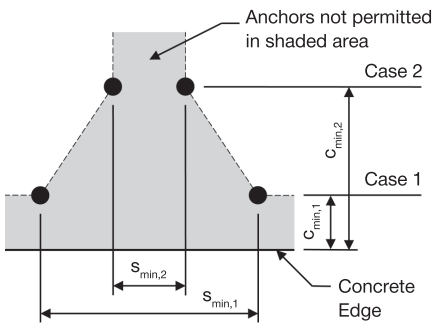

For a specific edge distance, the permitted spacing is calculated as follows:

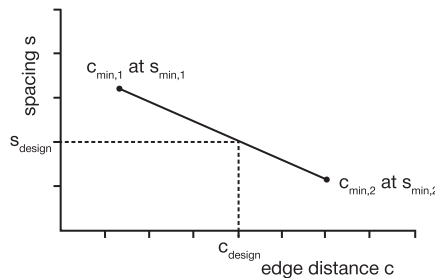

Table 6 – Load adjustment factors for M8, M10, and M12 Hilti HSL4 anchors in uncracked concrete^{1,2}

M8, M10 and M12 HSL4 uncracked concrete		Spacing factor in tension f_{AN}			Edge distance factor in tension f_{RN}			Spacing factor in shear f_{AV} ³			Edge distance in shear						Concrete thickness factor in shear f_{HV} ⁴		
											⊥ Toward edge f_{RV}			to and away from edge f_{RV}					
Nominal dia.		M8	M10	M12	M8	M10	M12	M8	M10	M12	M8	M10	M12	M8	M10	M12	M8	M10	M12
Effective embedment h_{ef}	in. (mm)	2.38 (60)	2.76 (70)	3.15 (80)	2.36 (60)	2.76 (70)	3.15 (80)	2.38 (60)	2.76 (70)	3.15 (80)	2.38 (60)	2.76 (70)	3.15 (80)	2.38 (60)	2.76 (70)	3.15 (80)	2.38 (60)	2.76 (70)	3.15 (80)
Spacing (s) / edge distance (c_a) / concrete thickness (h), - in (mm)	2-3/8 (60)	0.67	n/a	n/a	0.45	n/a	n/a	0.58	n/a	n/a	0.32	n/a	n/a	0.45	n/a	n/a	n/a	n/a	n/a
	2-1/2 (64)	0.68	n/a	n/a	0.47	n/a	n/a	0.58	n/a	n/a	0.35	n/a	n/a	0.47	n/a	n/a	n/a	n/a	n/a
	2-3/4 (70)	0.69	0.67	n/a	0.50	0.45	n/a	0.59	0.55	n/a	0.40	0.18	n/a	0.50	0.36	n/a	n/a	n/a	n/a
	3 (76)	0.71	0.68	n/a	0.53	0.48	n/a	0.60	0.56	n/a	0.46	0.20	n/a	0.53	0.41	n/a	n/a	n/a	n/a
	3-1/8 (79)	0.72	0.69	0.67	0.55	0.49	n/a	0.60	0.56	0.56	0.49	0.22	n/a	0.55	0.44	n/a	n/a	n/a	n/a
	3-1/2 (89)	0.75	0.71	0.69	0.60	0.53	0.48	0.62	0.57	0.56	0.58	0.26	0.23	0.60	0.52	0.46	n/a	n/a	n/a
	4 (102)	0.78	0.74	0.71	0.68	0.59	0.53	0.63	0.58	0.57	0.71	0.32	0.28	0.71	0.59	0.53	n/a	n/a	n/a
	4-3/8 (111)	0.81	0.76	0.73	0.74	0.64	0.56	0.65	0.58	0.58	0.81	0.36	0.32	0.81	0.64	0.56	0.76	n/a	n/a
	4-1/2 (114)	0.82	0.77	0.74	0.77	0.65	0.58	0.65	0.59	0.58	0.85	0.38	0.34	0.85	0.65	0.58	0.77	n/a	n/a
	4-3/4 (121)	0.84	0.79	0.75	0.81	0.69	0.60	0.66	0.59	0.59	0.92	0.41	0.37	0.92	0.69	0.60	0.79	0.61	n/a
	5 (127)	0.85	0.80	0.76	0.85	0.73	0.63	0.67	0.60	0.59	0.99	0.44	0.40	0.99	0.73	0.63	0.81	0.62	n/a
	5-3/8 (137)	0.88	0.83	0.78	0.91	0.78	0.68	0.68	0.60	0.60	1.00	0.49	0.44	1.00	0.78	0.68	0.84	0.64	0.62
	6 (152)	0.92	0.86	0.82	1.00	0.87	0.76	0.70	0.62	0.61		0.58	0.52		0.87	0.76	0.89	0.68	0.66
	7 (178)	0.99	0.92	0.87		1.00	0.89	0.73	0.64	0.63		0.73	0.65		1.00	0.89	0.96	0.73	0.71
	8 (203)	1.00	0.98	0.92			1.00	0.77	0.65	0.64		0.89	0.80			1.00	1.00	0.79	0.76
	9 (229)		1.00	0.98				0.80	0.67	0.66		1.00	0.95					0.83	0.80
	10 (254)		1.00	1.00				0.83	0.69	0.68			1.00					0.88	0.85
	12 (305)		1.00	1.00				0.90	0.73	0.72								0.96	0.93
	14 (356)			1.00				0.96	0.77	0.75								1.00	1.00
	16 (406)							1.00	0.81	0.79									
18 (457)								0.85	0.82										
20 (508)								0.89	0.86										
24 (610)								0.96	0.93										
> 30 (762)								1.00	1.00										

Table 7 – Load adjustment factors for M8, M10, and M12 Hilti HSL4 anchors in cracked concrete^{1,2}

M8, M10 and M12 HSL4 cracked concrete		Spacing factor in tension f_{AN}			Edge distance factor in tension f_{RN}			Spacing factor in shear f_{AV} ³			Edge distance in shear						Concrete thickness factor in shear f_{HV} ⁴		
											⊥ Toward edge f_{RV}			to and away from edge f_{RV}					
Nominal dia.		M8	M10	M12	M8	M10	M12	M8	M10	M12	M8	M10	M12	M8	M10	M12	M8	M10	M12
Effective embedment h_{ef}	in. (mm)	2.38 (60)	2.76 (70)	3.15 (80)	2.36 (60)	2.76 (70)	3.15 (80)	2.38 (60)	2.76 (70)	3.15 (80)	2.38 (60)	2.76 (70)	3.15 (80)	2.38 (60)	2.76 (70)	3.15 (80)	2.38 (60)	2.76 (70)	3.15 (80)
Spacing (s) / edge distance (c_a) / concrete thickness (h), - in (mm)	2-3/8 (60)	0.67	n/a	n/a	0.75	n/a	n/a	0.58	n/a	n/a	0.33	n/a	n/a	0.65	n/a	n/a	n/a	n/a	n/a
	2-1/2 (64)	0.68	n/a	n/a	0.78	n/a	n/a	0.58	n/a	n/a	0.35	n/a	n/a	0.71	n/a	n/a	n/a	n/a	n/a
	2-3/4 (70)	0.69	0.67	n/a	0.83	0.75	n/a	0.59	0.54	n/a	0.41	0.13	n/a	0.82	0.28	n/a	n/a	n/a	n/a
	3 (76)	0.71	0.68	n/a	0.88	0.79	n/a	0.60	0.55	n/a	0.46	0.15	n/a	0.88	0.29	n/a	n/a	n/a	n/a
	3-1/8 (79)	0.72	0.69	0.67	0.91	0.81	n/a	0.60	0.55	0.54	0.49	0.16	n/a	0.91	0.31	n/a	n/a	n/a	n/a
	3-1/2 (89)	0.75	0.71	0.69	0.99	0.88	0.80	0.62	0.55	0.55	0.59	0.18	0.17	0.99	0.37	0.33	n/a	n/a	n/a
	4 (102)	0.78	0.74	0.71	1.00	0.97	0.88	0.63	0.56	0.56	0.72	0.23	0.20	1.00	0.45	0.40	n/a	n/a	n/a
	4-3/8 (111)	0.81	0.76	0.73		1.00	0.94	0.65	0.57	0.56	0.82	0.26	0.23		0.51	0.46	0.76	n/a	n/a
	4-1/2 (114)	0.82	0.77	0.74		1.00	0.96	0.65	0.57	0.56	0.85	0.27	0.24		0.54	0.48	0.77	n/a	n/a
	4-3/4 (121)	0.84	0.79	0.75		1.00	1.00	0.66	0.57	0.57	0.93	0.29	0.26		0.58	0.52	0.80	0.54	n/a
	5 (127)	0.85	0.80	0.76		1.00	1.00	0.67	0.58	0.57	1.00	0.31	0.28		0.63	0.56	0.82	0.56	n/a
	5-3/8 (137)	0.88	0.83	0.78		1.00	1.00	0.68	0.58	0.58		0.35	0.31		0.70	0.63	0.85	0.58	0.56
	6 (152)	0.92	0.86	0.82		1.00	1.00	0.70	0.59	0.59		0.41	0.37		0.83	0.74	0.89	0.61	0.59
	7 (178)	0.99	0.92	0.87		1.00	1.00	0.73	0.61	0.60		0.52	0.47		1.00	0.93	0.97	0.66	0.63
	8 (203)	1.00	0.98	0.92			1.00	0.77	0.62	0.61		0.64	0.57			1.00	1.00	0.70	0.68
	9 (229)		1.00	0.98				0.80	0.67	0.63		1.00	0.68					0.74	0.72
	10 (254)		1.00	1.00				0.83	0.65	0.64		0.89	0.80					0.79	0.76
	12 (305)		1.00	1.00				0.90	0.69	0.67		1.00	1.00					0.86	0.83
	14 (356)			1.00				0.96	0.72	0.70								1.93	0.90
	16 (406)							1.00	0.75	0.73								0.99	0.96
18 (457)								0.78	0.76								1.00	1.00	
20 (508)								0.81	0.86										
24 (610)								0.87	0.84										
> 30 (762)								0.96	0.93										

1. Linear interpolation not permitted.
 2. When combining multiple load adjustment factors (e.g. for a 4 anchor pattern in a corner with thin concrete member) the design can become very conservative. To optimize the design, use Hilti PROFIS Engineering software or perform anchor calculation using design equations from ACI 318 Chapter 17.
 3. Spacing factor reduction in shear, f_{AV} , assumes an influence of a nearby edge. If no edge exists, then $f_{AV} = f_{AN}$.
 4. Concrete thickness reduction factor in shear, f_{HV} , assumes an influence of a nearby edge. If no edge exists, then $f_{HV} = 1.0$.
 If a reduction factor value is in a shaded cell, it may not be permitted if both edge and spacing are less than "critical" distances. Check table 5 and figure 2 of this section to calculate permissible edge distance, spacing and concrete thickness combinations. For the HSL4-SH M8, M10 and M12 diameters, the minimum slab thickness must be increased by 5 mm (3/16-in.).

Table 8 – Load adjustment factors for M16, M20, and M24 Hilti HSL4 anchors in uncracked concrete^{1,2}

M16, M20 and M24 HSL4 uncracked concrete	Spacing factor in tension f_{AN}			Edge distance factor in tension f_{RN}			Spacing factor in shear ³ f_{AV}			Edge distance in shear						Concrete thickness factor in shear ⁴ f_{HV}			
										⊥ Toward edge f_{RV}			to and away from edge f_{RV}						
Nominal dia.	M16	M20	M24	M16	M20	M24	M16	M20	M24	M16	M20	M24	M16	M20	M24	M16	M20	M24	
Effective embedment h_{ef}	in. (mm)	3.948 (100)	4.92 (125)	5.91 (150)	3.948 (100)	4.92 (125)	5.91 (150)	3.948 (100)	4.92 (125)	5.91 (150)	3.948 (100)	4.92 (125)	5.91 (150)	3.948 (100)	4.92 (125)	5.91 (150)	3.948 (100)	4.92 (125)	5.91 (150)
Spacing (s) / edge distance (c_a) / concrete thickness (h_c) - in (mm)	4 (102)	0.67	n/a	n/a	n/a	n/a	n/a	n/a	n/a	0.56	n/a	n/a	n/a	n/a	n/a	n/a	n/a	n/a	n/a
	4-1/2 (114)	0.69	n/a	n/a	n/a	n/a	n/a	n/a	n/a	0.57	n/a	n/a	n/a	n/a	n/a	n/a	n/a	n/a	n/a
	4-3/4 (121)	0.70	n/a	n/a	0.51	n/a	n/a	0.58	n/a	n/a	0.30	n/a	n/a	0.51	n/a	n/a	n/a	n/a	n/a
	5 (127)	0.71	0.67	n/a	0.53	0.45	n/a	0.58	0.57	n/a	0.33	0.25	n/a	0.53	0.45	n/a	n/a	n/a	n/a
	5-1/2 (140)	0.73	0.69	n/a	0.57	0.48	n/a	0.59	0.57	n/a	0.38	0.29	n/a	0.57	0.48	n/a	n/a	n/a	n/a
	5-7/8 (149)	0.75	0.70	0.67	0.60	0.50	0.45	0.59	0.58	0.57	0.42	0.32	0.26	0.60	0.50	0.45	n/a	n/a	n/a
	6 (152)	0.75	0.70	0.67	0.61	0.51	0.45	0.59	0.58	0.57	0.43	0.33	0.27	0.61	0.51	0.45	n/a	n/a	n/a
	6-1/4 (159)	0.76	0.71	0.68	0.63	0.53	0.47	0.60	0.58	0.57	0.46	0.35	0.29	0.63	0.53	0.47	0.63	n/a	n/a
	7 (178)	0.80	0.74	0.70	0.71	0.57	0.50	0.61	0.59	0.58	0.54	0.42	0.34	0.71	0.57	0.50	0.67	n/a	n/a
	7-1/2 (191)	0.82	0.75	0.71	0.76	0.61	0.53	0.62	0.60	0.59	0.60	0.46	0.38	0.76	0.61	0.53	0.69	0.63	n/a
	8 (203)	0.84	0.77	0.73	0.81	0.65	0.55	0.63	0.61	0.59	0.66	0.51	0.41	0.81	0.65	0.55	0.71	0.65	n/a
	8-7/8 (225)	0.88	0.80	0.75	0.90	0.72	0.60	0.64	0.62	0.60	0.77	0.60	0.48	0.90	0.72	0.60	0.75	0.69	0.64
	9 (229)	0.88	0.80	0.75	0.91	0.73	0.61	0.64	0.62	0.60	0.79	0.61	0.49	0.91	0.73	0.61	0.75	0.69	0.65
	10 (254)	0.92	0.84	0.78	1.00	0.81	0.68	0.66	0.63	0.62	0.92	0.71	0.58	1.00	0.81	0.68	0.79	0.73	0.68
	11 (279)	0.97	0.87	0.81	1.00	0.89	0.75	0.67	0.65	0.63	1.00	0.82	0.67	1.00	0.89	0.75	0.83	0.77	0.71
	12 (305)	1.00	0.91	0.84		0.97	0.81	0.69	0.66	0.64		0.94	0.76		0.97	0.81	0.87	0.80	0.75
	14 (356)	1.00	0.97	0.90		1.00	0.95	0.72	0.69	0.66		1.00	0.96		1.00	0.96	0.94	0.86	0.80
	16 (406)	1.00	1.00	0.95			1.00	0.75	0.71	0.69			1.00			1.00	1.00	0.92	0.86
	18 (457)			1.00				0.78	0.74	0.71								0.98	0.91
20 (508)							0.82	0.77	0.73								1.00	0.96	
24 (610)							0.88	0.82	0.78									1.00	
30 (762)							0.97	0.90	0.85										
36 (914)							1.00	0.98	0.92										
> 48 (1219)							1.00	1.00											

3.3.2

Table 9 – Load adjustment factors for M8, M10, and M12 Hilti HSL4 anchors in cracked concrete^{1,2}

M16, M20 and M24 HSL4 cracked concrete	Spacing factor in tension f_{AN}			Edge distance factor in tension f_{RN}			Spacing factor in shear ³ f_{AV}			Edge distance in shear						Concrete thickness factor in shear ⁴ f_{HV}			
										⊥ Toward edge f_{RV}			to and away from edge f_{RV}						
Nominal dia.	M16	M20	M24	M16	M20	M24	M16	M20	M24	M16	M20	M24	M16	M20	M24	M16	M20	M24	
Effective embedment h_{ef}	in. (mm)	3.948 (100)	4.92 (125)	5.91 (150)	3.948 (100)	4.92 (125)	5.91 (150)	3.948 (100)	4.92 (125)	5.91 (150)	3.948 (100)	4.92 (125)	5.91 (150)	3.948 (100)	4.92 (125)	5.91 (150)	3.948 (100)	4.92 (125)	5.91 (150)
Spacing (s) / edge distance (c_a) / concrete thickness (h_c) - in (mm)	4 (102)	0.67	n/a	n/a	n/a	n/a	n/a	n/a	n/a	n/a	n/a	n/a	n/a	n/a	n/a	n/a	n/a	n/a	
	4-1/2 (114)	0.69	n/a	n/a	n/a	n/a	n/a	n/a	n/a	n/a	n/a	n/a	n/a	n/a	n/a	n/a	n/a	n/a	
	4-3/4 (121)	0.70	n/a	n/a	0.85	n/a	n/a	0.56	n/a	n/a	0.22	n/a	n/a	0.43	n/a	n/a	n/a	n/a	
	5 (127)	0.71	0.67	n/a	0.88	0.76	n/a	0.56	0.55	n/a	0.23	0.18	n/a	0.47	0.36	n/a	n/a	n/a	
	5-1/2 (140)	0.73	0.69	n/a	0.95	0.81	n/a	0.57	0.56	n/a	0.27	0.21	n/a	0.54	0.42	n/a	n/a	n/a	
	5-7/8 (149)	0.75	0.70	0.67	1.00	0.84	0.75	0.57	0.56	0.55	0.30	0.23	0.19	0.59	0.46	0.37	n/a	n/a	
	6 (152)	0.75	0.70	0.67	1.00	0.86	0.76	0.58	0.56	0.56	0.31	0.24	0.19	0.61	0.47	0.38	n/a	n/a	
	6-1/4 (159)	0.76	0.71	0.68	1.00	0.88	0.78	0.58	0.57	0.56	0.33	0.25	0.20	0.65	0.50	0.41	0.56	n/a	
	7 (178)	0.80	0.74	0.70	1.00	0.96	0.84	0.59	0.57	0.56	0.39	0.30	0.24	0.77	0.60	0.48	0.59	n/a	
	7-1/2 (191)	0.82	0.75	0.71	1.00	1.00	0.88	0.59	0.58	0.57	0.43	0.33	0.27	0.86	0.66	0.54	0.62	0.56	
	8 (203)	0.84	0.77	0.73	1.00	1.00	0.92	0.60	0.59	0.57	0.47	0.36	0.30	0.94	0.73	0.59	0.64	0.58	
	8-7/8 (225)	0.88	0.80	0.75	1.00	1.00	1.00	0.61	0.59	0.58	0.55	0.43	0.35	1.00	0.85	0.69	0.67	0.61	
	9 (229)	0.88	0.80	0.75	1.00	1.00	1.00	0.61	0.60	0.58	0.56	0.43	0.35	1.00	0.87	0.71	0.67	0.62	
	10 (254)	0.92	0.84	0.78	1.00	1.00	1.00	0.63	0.61	0.59	0.66	0.51	0.41	1.00	1.00	0.83	0.71	0.65	
	11 (279)	0.97	0.87	0.81	1.00	1.00	1.00	0.64	0.62	0.60	0.76	0.59	0.48	1.00	1.00	0.95	0.75	0.68	
	12 (305)	1.00	0.91	0.84		1.00	1.00	0.65	0.63	0.61	0.87	0.67	0.54		1.00	1.00	0.78	0.71	
	14 (356)	1.00	0.97	0.90			1.00	0.68	0.65	0.63	1.00	0.84	0.68			1.00	0.84	0.77	
	16 (406)	1.00	1.00	0.95				0.70	0.67	0.65		1.00	0.84				0.90	0.82	
	18 (457)			1.00				0.73	0.69	0.67			1.00				0.95	0.87	
20 (508)							0.75	0.71	0.68			1.00				1.00	0.92		
24 (610)							0.80	0.76	0.72								1.00		
30 (762)							0.88	0.82	0.78										
36 (914)							0.95	0.88	0.83										
> 48 (1219)							1.00	1.00	0.94										

1. Linear interpolation not permitted.
 2. When combining multiple load adjustment factors (e.g. for a 4 anchor pattern in a corner with thin concrete member) the design can become very conservative. To optimize the design, use Hilti PROFIS Engineering software or perform anchor calculation using design equations from ACI 318 Chapter 17.
 3. Spacing factor reduction in shear, f_{AV} , assumes an influence of a nearby edge. If no edge exists, then $f_{AV} = f_{AN}$.
 4. Concrete thickness reduction factor in shear, f_{HV} , assumes an influence of a nearby edge. If no edge exists, then $f_{HV} = 1.0$.
 If a reduction factor value is in a shaded cell, it may not be permitted if both edge and spacing are less than "critical" distances. Check table 5 and figure 2 of this section to calculate permissible edge distance, spacing and concrete thickness combinations. For the HSL4-SH M8, M10 and M12 diameters, the minimum slab thickness must be increased by 5 mm (3/16-in.).

DESIGN INFORMATION IN CONCRETE PER CSA A23.3

Limit State Design of anchors is described in the provisions of CSA A23.3 Annex D for post-installed anchors tested and assessed in accordance with ACI 355.2 for mechanical anchors and ACI 355.4 for adhesive anchors. This section contains the Limit State Design tables with unfactored characteristic loads that are based on the published loads in ICC Evaluation Services ESR-4386. These tables are followed by factored resistance tables. The factored resistance tables have characteristic design loads that are prefactored by the applicable reduction factors for a single anchor with no anchor-to-anchor spacing or edge distance adjustments for the convenience of the user of this document. All the figures in the previous ACI 318 Chapter 17 design section are applicable to Limit State Design and the tables will reference these figures.

For a detailed explanation of the tables developed in accordance with CSA A23.3 Annex D, refer to PTG Ed. 21 Section 3.1.8. Technical assistance is available by contacting Hilti Canada at (800) 363-4458 or at www.hilti.com.

Table 10 — Steel strength for Hilti HSL4 anchors^{1,2}



Nominal anchor diameter	HSL4, HSL4-B, HSL4-SK			HSL4-G		
	Tensile ³ ϕN_{sa} lb (kN)	Shear ⁴ ϕV_{sa} lb (kN)	Seismic shear ⁵ $\phi V_{sa,eq}$ lb (kN)	Tensile ³ ϕN_{sa} lb (kN)	Shear ⁴ ϕV_{sa} lb (kN)	Seismic shear ⁵ $\phi V_{sa,eq}$ lb (kN)
M8	4,495 (20.0)	4,615 (20.5)	2,940 (13.1)	4,495 (20.0)	3,870 (17.2)	2,410 (10.7)
M10	7,100 (31.6)	6,520 (29.0)	5,390 (24.0)	7,100 (31.6)	5,345 (23.8)	4,415 (19.6)
M12	10,335 (46.0)	9,385 (41.7)	7,580 (33.7)	10,335 (46.0)	7,755 (34.5)	6,265 (27.9)
M16	19,170 (94.0)	17,025 (75.7)	15,805 (70.3)	19,170 (85.3)	14,460 (64.3)	13,430 (59.7)
M20	29,975 (133.3)	25,195 (112.1)	18,575 (82.6)	29,975 (133.3)	21,140 (94.0)	15,595 (69.4)
M24	43,145 (191.9)	29,295 (130.3)	24,335 (108.2)	43,145 (191.0)	27,520 (122.4)	n/a

1. See PTG Ed. 21 section 3.1.8 to convert design strength value to ASD value.
2. Hilti HSL4 anchors are to be considered ductile steel elements.
3. Tensile $N_{sar} = A_{se} N \phi_s f_{uta} R$ as noted in CSA A23.3 Annex D.
4. Shear determined by static shear tests with $V_{sar} < A_{se} V \phi_s 0.6 f_{uta} R$ as noted in CSA A23.3 Annex D.
5. Seismic shear values determined by seismic shear tests with $V_{sar,eq} < A_{se} V \phi_s 0.6 f_{uta} R$ as noted in CSA A23.3 Annex D. See Section 3.1.8 for additional information on seismic applications.



Table 11 – Hilti HSL4 design information in accordance with CSA A23.3 Annex D¹

Design parameter	Symbol	Units	Nominal anchor diameter						Ref A23.3
			M8	M10	M12	M16	M20	M24	
Anchor O.D.	d_a	mm (in.)	12 (0.47)	15 (0.59)	18 (0.71)	21 (0.94)	28 (1.10)	32 (1.26)	
Effective minimum embedment ²	h_{ef}	mm (in.)	60 (2.4)	70 (2.8)	80 (3.1)	100 (3.9)	125 (4.9)	150 (5.9)	
Minimum concrete thickness	h_{min}	mm (in.)	See table 5						
Critical edge distance	c_{ac}	mm (in.)	See table 5						
Minimum edge distance	c_{min}	mm (in.)	See table 5						
	for $s >$	mm (in.)	See table 5						
Minimum anchor spacing	s_{min}	mm (in.)	See table 5						
	for $c >$	mm (in.)	See table 5						
Minimum hole depth in concrete	h_o	mm (in.)	80 (3.1)	90 (3.5)	105 (4.1)	125 (4.9)	155 (6.1)	190 (7.5)	
Minimum specified yield strength	f_{ya}	N/mm ² (psi)	641 (93,000)						
Minimum specified ultimate strength	f_{uta}	N/mm ² (psi)	800 (116,000)						
Effective tensile stress area	$A_{se,N}$	mm ² (in ²)	36.8 (0.057)	58.1 (0.090)	84.5 (0.131)	156.8 (0.243)	245.2 (0.380)	352.9 (0.547)	
Steel embed. material resistance factor for reinforcement	ϕ_s	-	0.85						8.4.3
Resistance modification factor for tension, steel failure modes ³	R	-	0.80						D.5.3
Resistance modification factor for shear, steel failure modes ³	R	-	0.75						D.5.3
Factored steel resistance in tension	N_{sar}	lb (kN)	4,495 (20.0)	7,100 (31.6)	10,335 (46.0)	19,170 (85.3)	29,975 (133.3)	43,145 (191.9)	D.6.1.2
Factored steel resistance in shear HSL4, HSL-B, HSL4-SK	V_{sar}	lb (kN)	4,615 (20.5)	6,520 (29.0)	9,385 (41.7)	17,025 (75.7)	25,195 (112.1)	29,295 (130.3)	D.7.1.2
Factored steel resistance in shear HSL4-G		lb (kN)	3,870 (17.2)	5,345 (23.8)	7,755 (34.5)	14,460 (62.3)	21,140 (94.0)	27,520 (122.4)	D.7.1.2
Factored steel resistance in shear, seismic HSL4, HSL-B, HSL4-SK	$V_{sar,eq}$	lb (kN)	2,940 (13.1)	5,390 (24.0)	7,580 (33.7)	15,805 (70.3)	18,575 (82.6)	24,335 (108.3)	
Factored steel resistance in shear, seismic HSL4-G		lb (kN)	2,410 (10.7)	4,415 (19.6)	6,265 (27.9)	13,430 (59.7)	15,595 (69.4)	n/a ⁷	
Coeff. for factored conc. breakout resistance, uncracked concrete	$k_{c,uncr}$	-	10						D.6.2.2
Coeff. for factored conc. breakout resistance, cracked concrete	$k_{c,cr}$	-	7	10					D.6.2.2
Modification factor for anchor resistance, tension, uncracked concrete ⁴	$\psi_{c,N}$	-	1.0						D.6.2.6
Anchor category	-	-	1.0						D.5.3(c)
Concrete material resistance factor	ϕ_c	-	0.65						8.4.2
Resistance modification factor for tension and shear, concrete failure modes, Condition B ⁵	R	-	1.0						D.5.3(c)
Factored pullout resistance in 20 MPa uncracked concrete ⁶	$N_{pr,uncr}$	lb (kN)	2,945 (13.1)	n/a	n/a	n/a	n/a	n/a	D.6.3.2
Factored pullout resistance in 20 MPa cracked concrete ⁶	$N_{pr,cr}$	lb (kN)	1,970 (8.8)	3,150 (14.0)	n/a	n/a	n/a	n/a	D.6.3.2
Factored seismic pullout resistance in 20 MPa cracked concrete ⁶	$N_{pr,eq}$	lb (kN)	1,970 (8.8)	3,150 (14.0)	n/a	n/a	n/a	10,030 ⁷ (44.6)	
Load bearing length of anchor in shear	l_e	mm (in.)	24 (0.94)	30 (1.18)	36 (1.42)	48 (1.89)	56 (2.20)	64 (2.52)	D.7.2.2

3.3.2

1 Design information in this table is taken from ICC-ES ESR-4386, table 3, and converted for use with CSA A23.3 Annex D.
 2 See Figure 1 of this document.
 3 The HSL4 is considered a ductile steel element as defined by CSA A23.3 Annex D section D.2.
 4 For all design cases, $\psi_{c,N} = 1.0$. The appropriate coefficient for breakout resistance for cracked concrete ($k_{c,cr}$) or uncracked concrete ($k_{c,uncr}$) must be used.
 5 For use with the load combinations of CSA A23.3 chapter 8. Condition B applies where supplementary reinforcement in conformance with CSA A23.3 section D.5.3 is not provided, or where pullout or pryout strength governs. For cases where the presence of supplementary reinforcement can be verified, the resistance modification factors associated with Condition A may be used.
 6 For all design cases, $\psi_{c,p} = 1.0$. NA (not applicable) denotes that this value does not control for design. See section 4.1.4 of ESR-4386 for additional information.
 7 HSL4-G M24 is not permitted for seismic applications.

Table 12 — Hilti HSL4 anchors factored resistance with concrete/pullout failure in uncracked concrete^{1,2,3,4,5}

Nominal anchor diameter	Effective embedment, mm (in.)	Tension - ϕN_n				Shear - ϕV_n			
		$f'_c = 20$ MPa (2,900psi) lb (kN)	$f'_c = 25$ MPa (3,625 psi) lb (kN)	$f'_c = 30$ MPa (4,350 psi) lb (kN)	$f'_c = 40$ MPa (5,800 psi) lb (kN)	$f'_c = 20$ MPa (2,900 psi) lb (kN)	$f'_c = 25$ MPa (3,625 psi) lb (kN)	$f'_c = 30$ MPa (4,350 psi) lb (kN)	$f'_c = 40$ MPa (5,800 psi) lb (kN)
M8	60 (2.4)	2,945 (13.1)	3,290 (14.6)	3,605 (16.0)	4,165 (18.5)	3,035 (13.5)	3,395 (15.1)	3,720 (16.5)	4,295 (19.1)
M10	70 (2.8)	3,825 (17.0)	4,280 (19.0)	4,685 (20.9)	5,415 (24.1)	7,655 (34.0)	8,560 (38.1)	9,375 (41.7)	10,825 (48.2)
M12	80 (3.1)	4,675 (20.8)	5,230 (23.3)	5,725 (25.5)	6,615 (29.4)	9,350 (41.6)	10,455 (46.5)	11,455 (50.9)	13,225 (58.8)
M16	100 (3.9)	6,535 (29.1)	7,305 (32.5)	8,005 (35.6)	9,240 (41.1)	13,070 (58.1)	14,615 (65.0)	16,005 (71.2)	18,485 (82.2)
M20	125 (4.9)	9,135 (40.6)	10,210 (45.4)	11,185 (49.8)	12,915 (57.5)	18,265 (81.3)	20,420 (90.8)	22,370 (99.5)	25,830 (114.9)
M24	150 (5.9)	12,005 (53.4)	13,425 (59.7)	14,705 (65.4)	16,980 (75.5)	24,010 (106.8)	26,845 (119.4)	29,405 (130.8)	33,955 (151.0)

Table 13 — Hilti HSL4 anchor factored resistance with concrete / pullout failure in cracked concrete^{1,2,3,4,5}

Nominal anchor diameter	Effective embedment, mm (in.)	Tension - ϕN_n				Shear - ϕV_n			
		$f'_c = 20$ MPa (2,900psi) lb (kN)	$f'_c = 25$ MPa (3,625 psi) lb (kN)	$f'_c = 30$ MPa (4,350 psi) lb (kN)	$f'_c = 40$ MPa (5,800 psi) lb (kN)	$f'_c = 20$ MPa (2,900 psi) lb (kN)	$f'_c = 25$ MPa (3,625 psi) lb (kN)	$f'_c = 30$ MPa (4,350 psi) lb (kN)	$f'_c = 40$ MPa (5,800 psi) lb (kN)
M8	60 (2.4)	1,970 (8.8)	2,200 (9.8)	2,410 (10.7)	2,785 (12.4)	2,125 (9.5)	2,375 (10.6)	2,605 (11.6)	3,005 (13.4)
M10	70 (2.8)	3,150 (17.0)	3,520 (19.0)	3,855 (20.9)	4,455 (24.1)	7,655 (34.0)	8,560 (38.1)	9,375 (41.7)	10,825 (48.2)
M12	80 (3.1)	4,675 (20.8)	5,230 (23.3)	5,725 (25.5)	6,615 (29.4)	9,350 (41.6)	10,455 (46.5)	11,455 (50.9)	13,225 (58.8)
M16	100 (3.9)	6,535 (29.1)	7,305 (32.5)	8,005 (35.6)	9,240 (41.1)	13,070 (58.1)	14,615 (65.0)	16,005 (71.2)	18,485 (82.2)
M20	125 (4.9)	9,135 (40.6)	10,210 (45.4)	11,185 (49.8)	12,915 (57.5)	18,265 (81.3)	20,420 (90.8)	22,370 (99.5)	25,830 (114.9)
M24 ⁵	150 (5.9)	12,005 (53.4)	13,425 (59.7)	14,705 (65.4)	16,980 (75.5)	24,010 (106.8)	26,845 (119.4)	29,405 (130.8)	33,955 (151.0)

1 See PTG Ed. 21 section 3.1.8 to convert design strength value to ASD value.

2 Linear interpolation between embedment depths and concrete compressive strengths is not permitted.

3 Apply spacing, edge distance, and concrete thickness factors in tables 6 to 9 as necessary. Compare to the steel values in table 10. The lesser of the values is to be used for the design.

4 Tabular values are for normal weight concrete only. For lightweight concrete multiply design strength by λ_s as follows: for sand-lightweight, $\lambda_s = 0.68$; for all-lightweight, $\lambda_s = 0.60$.

5 Tabular values are for static loads only. Seismic design is not permitted for uncracked concrete. For seismic tension loads, multiply cracked concrete tabular values in tension only by the following reduction factors:

M24 - $\alpha_{N,seis} = 0.62$. HSL4-G M24 is not permitted for seismic applications.

All other sizes - $\alpha_{N,seis} = 0.75$

No reduction needed for seismic shear. See PTG Ed. 21 section 3.1.8 for additional information on seismic applications.

INSTALLATION INSTRUCTIONS

Installation Instructions For Use (IFU) are included with each product package. They can also be viewed or downloaded online at www.hilti.com. Because of the possibility of changes, always verify that downloaded IFU are current when used. Proper installation is critical to achieve full performance. Training is available on request. Contact Hilti Technical Services for applications and conditions not addressed in the IFU.

ORDERING INFORMATION



HSL4 Bolt version

Description	Box qty
HSL4 M8 d12x97 20/-/-	40
HSL4 M8 d12x117 40/20/-	40
HSL4 M10 d15x109 20/-/-	20
HSL4 M10 d15x129 40/20/-	20
HSL4 M12 d18x131 25/-/-	20
HSL4 M12 d18x156 50/25/-	20
HSL4 M16 d24x138 10/-/-	10
HSL4 M16 d24x153 25/-/-	10
HSL4 M16 d24x178 50/25/-	10
HSL4 M20 d28x183 30/-/-	6
HSL4 M20 d28x213 60/30/-	6
HSL4 M24 d32x205 30/-/-	4
HSL4 M24 d32x235 60/30/-	4



HSL4-B Torque cap

Description	Box qty
HSL4-B M12 d18x121 5/-/-	20
HSL4-B M12 d18x141 25/-/-	20
HSL4-B M12 d18x166 50/25/-	10
HSL4-B M16 d24x151 10/-/-	10
HSL4-B M16 d24x166 25/-/-	10
HSL4-B M20 d28x198 30/-/-	6
HSL4-B M24 d32x223 30/-/-	4

3.3.2



HSL4-G Stud version

Description	Box qty
HSL4-G M8 d12x107 20/-/-	40
HSL4-G M10 d15x121 20/-/-	20
HSL4-G M10 d15x201 100/80/60	20
HSL4-G M12 d18x147 25/-/-	20
HSL4-G M12 d18x172 50/25/-	20
HSL4-G M16 d24x175 25/-/-	10
HSL4-G M16 d24x200 50/25/-	10
HSL4-G M20 d28x205 30/-/-	6
HSL4-G M20 d28x235 60/30/-	6



HSL4-SK Countersunk

Description	Box qty
HSL4-SK M8 d12x80 10/-/-	20
HSL4-SK M8 d12x90 20/-/-	20
HSL4-SK M10 d15x100 20/-/-	10
HSL4-SK M12 d18x120 25/-/-	10

Product nomenclature

HSL4-G M10 d15x201 100/80/60

A B C D E

- A: Anchor Name
- B: Threaded rod diameter
- C: Drill bit diameter
- D: Total length of the anchor
- E: Maximum fixture thickness at Min/Std/Max effective embedment