

**POST-INSTALLED MECHANICAL ANCHORS**  
SUITABILITY AND EMBEDMENT TO BE VERIFIED BY ENGINEER OF RECORD

**POST-INSTALLED ADHESIVE ANCHORS**  
SUITABILITY AND EMBEDMENT TO BE VERIFIED BY ENGINEER OF RECORD

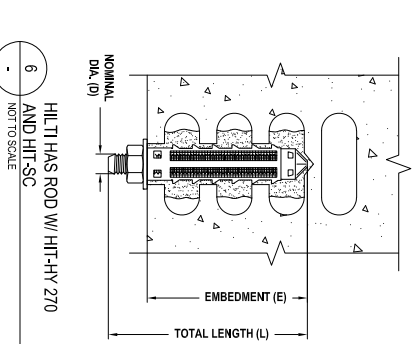

**CAST-IN ANCHORS**  
SUITABILITY AND EMBEDMENT TO BE VERIFIED BY ENGINEER OF RECORD

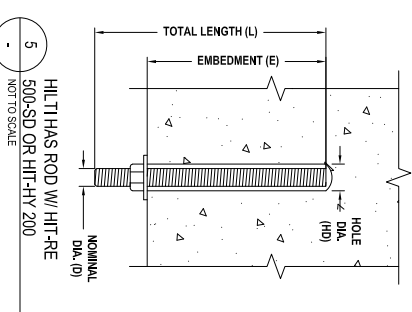
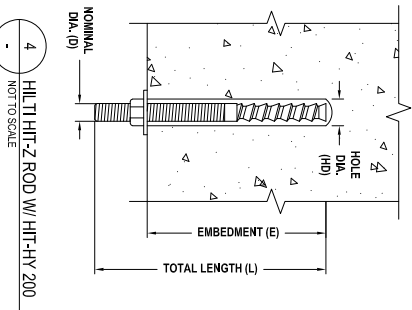
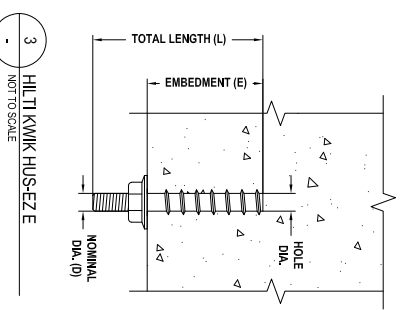
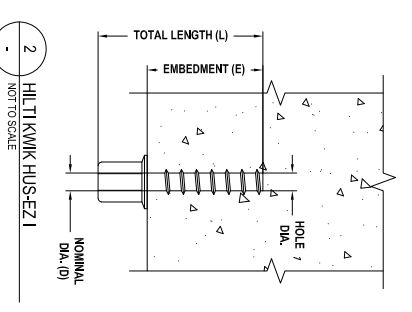
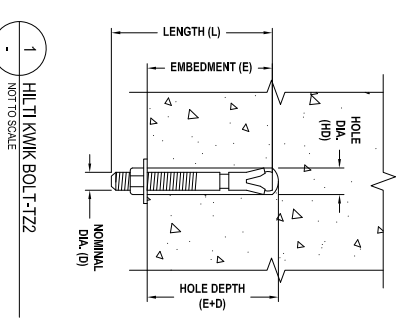
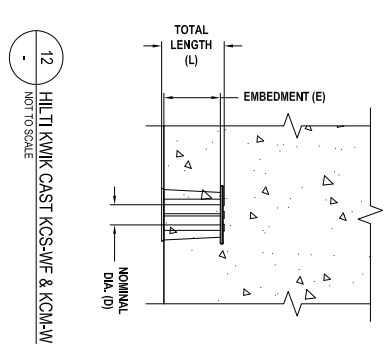
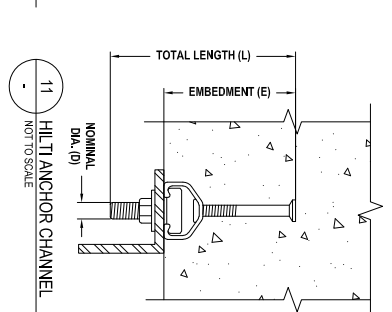
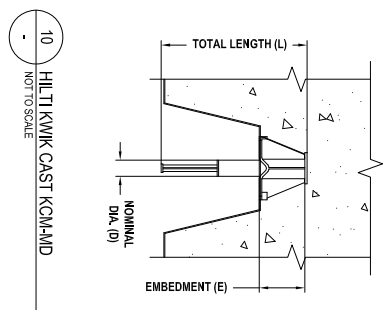
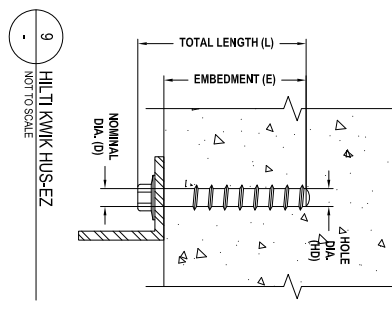
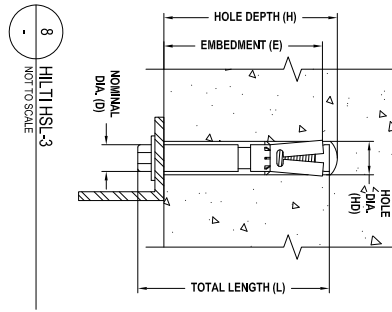
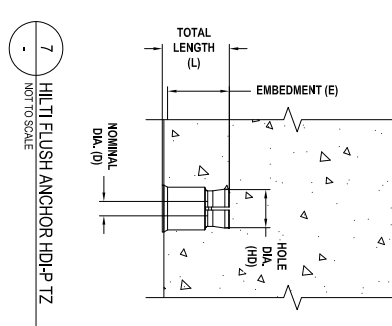

**Notes:**

1) Except where indicated on the drawings, post-installed anchors shall consist of the following anchor types as provided by Hilti, Inc. Contact Hilti at (800) 879-8000 for product related questions.

**a) Anchorage to concrete**

1) Adhesive anchors for cracked and uncracked concrete use:

(1) **HILTI HIT-HY 200 Safe Set System with HILTI HIT-Z ROD** Per ICC ESR-3187

(2) **HILTI HIT-HY 200 Safe Set System with HILTI HIT-Z ROD Per ICC ESR-3187**

(3) **HILTI HIT-RE 500 V3 Safe Set System with HILTI Hollow Drill Bit and Vacuum with HAS Threaded Rod per ICC ESR-3814**

(4) **HILTI HIT-RE 500 V3 Safe Set System with HILTI Roughening Tool (HIT RT) with HAS Threaded Rod per ICC ESR-3814 for Diamond Cored Holes**

(5) **Steel Elements for use with adhesive:**

(a) **HILTI HAS-V-36 GRADE 36 Carbon Steel Rod**

(b) **HILTI HAS-E-55 GRADE 55 Carbon Steel Rod**

(c) **HILTI HAS-B-105 GRADE 105 Carbon Steel Rod**

(d) **HILTI HAS-R-304 Stainless Steel Rod**

(e) **HILTI HAS-R-316 Stainless Steel Rod**

(f) **HILTI HIT-Z ROD (with HY 200 only)**

ii) **Medium Duty Mechanical Anchors for cracked and uncracked concrete use:**

(1) **HILTI KWIK HUS-EZ and KWIK HUS-EZ1, and KWIK HUS-EZ Expansion Anchor Safe Set System with Hollow Drill Bit and Vacuum per ICC ESR-3027**

(2) **HILTI KWIK BOLT-TZZ Expansion Anchor Safe Set System with Hollow Drill Bit and Vacuum and SHAT-A22 Tool with adaptive torque for applicable sizes per ICC ESR-4266**

(3) **HILTI KWIK BOLT-1 Expansion Anchor Safe Set System with Hollow Drill Bit and Vacuum and SHAT-A22 Tool with adaptive torque for applicable sizes per IAPMO ER-678**

**b) Anchorage to Solid Grouted Masonry**

i) **Adhesive Anchors Use:**

(1) **HILTI HIT-HY 270 Safe Set System with HILTI Hollow Drill Bit and Vacuum per ICC ESR-143**

(2) **Steel Anchor Element shall be HILTI HAS continuously threaded rod or continuously deformed steel rebar**

**c) Anchorage to Hollow / Multi-Wythe Masonry**

i) **Adhesive Anchors Use:**

(1) **HILTI HIT-HY 270 Safe Set System with HILTI Hollow Drill Bit and Vacuum per ICC ESR-143**

(2) **Steel Anchor Element shall be HILTI HAS continuously threaded rod or continuously deformed steel rebar**

(3) **The appropriate size screen tube shall be used per adhesive manufacturer's printed installation instructions**

ii) **Mechanical Anchors Use:**

(1) **HILTI KWIK HUS-EZ Screw Anchor per ICC ESR-3056**

(2) **HILTI KWIK BOLT-TZZ Expansion Anchor per ICC ESR-4266**

(3) **HILTI KWIK BOLT-1 Expansion Anchor per IAPMO ER-677**

2) Anchor capacity used in design shall be based on the technical data published by Hilti or other such method as approved by the structural engineer of record. Substitution requests for alternate products or drilling methods must be approved in writing by the structural engineer of record prior to use. Contractor shall provide calculations demonstrating that the substituted product meets or exceeds the performance capacities of the specified product. Substitutions will be evaluated by their having an ICC ESR showing compliance with the relevant building code for seismic uses, load resistance, installation category, and availability of comprehensive installation instructions. Adhesive anchor evaluation will also consider Creep, In-service temperature, and installation temperature.

3) Use of Diamond Core Bit with roughening tool for anchor holes requires approval from engineer of record prior to drilling. Unless otherwise shown in the drawings, all holes shall be drilled perpendicular to the concrete surface.

4) Install anchors per the manufacturer's printed installation instructions, as included in the anchor packaging.

5) Overhead Adhesive Anchors must be installed using the Hilti Proof Piston Plug System.

6) The contractor shall arrange an anchor manufacturer's representative to provide onsite installation training for all anchor products specified. The structural engineer of record must receive documented confirmation that all personnel who install anchors are trained prior to the commencement of anchor installation.

7) Anchor capacity is dependent upon spacing between adjacent anchors and proximity of anchors to edge of concrete. Install anchors in accordance with spacing and edge clearances indicated on the drawings.

8) Existing reinforcing bars in the concrete structure may conflict with specific anchor locations. Unless noted on the drawings that the bars can be cut, the contractor shall review the existing structural drawings and shall undertake to locate the position of the reinforcing bars at the locations of the concrete anchors by Hilti **PS 1000** or other GPR, x-ray, chipping or other approved means.

<Notes to designer (delete this note after reading and replace with title block information)>  
1. Any modification to these details could result in an application not meeting the requirements per the ICC ESR or technical data published by HILTI.  
2. Details shown are up to date as of May 2019.  
3. For additional information on the details, refer to the most current published HILTI technical guide or supplement located at [www.hilti.com](http://www.hilti.com)