

PLAN VIEW

BOLT DESCRIPTION	ITEM NUMBER	BOLT LENGTH, "L" IN. [MM]
HBC-B M12x40 4.6 F	433534	1.57 [40]
HBC-B M12x60 4.6 F	433535	2.36 [60]

NOTE: NUT IS INCLUDED WITH T-BOLT

ITEM	WASHER DESCRIPTION	ITEM NUMBER
A	FLAT WASHER A 13/24-F	304771
B	M12 SPLIT WASHER DIN127 HDG	2150395

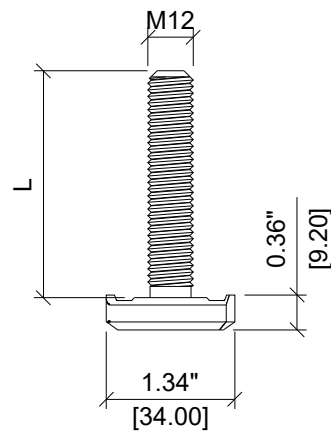

ELEVATION VIEW

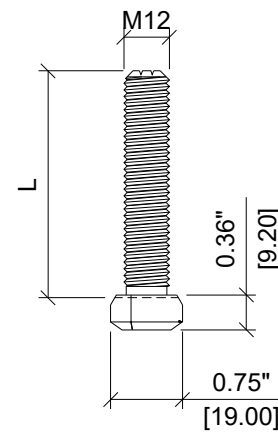

SIDE VIEW

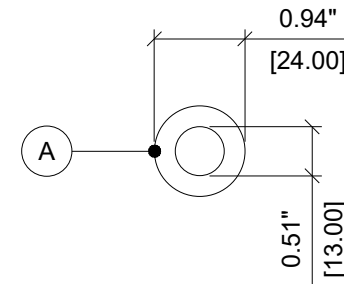

PLAN VIEW

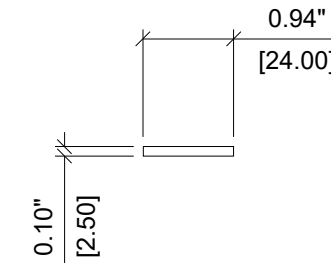

SIDE VIEW

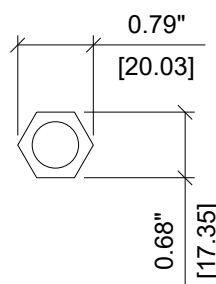

PLAN VIEW

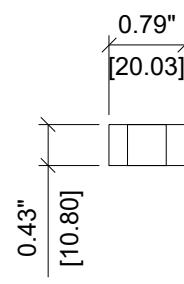

SIDE VIEW

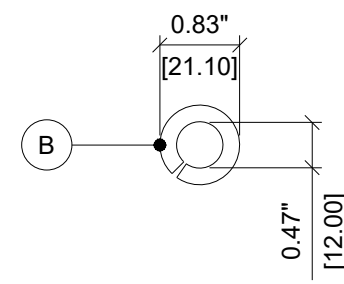

PLAN VIEW

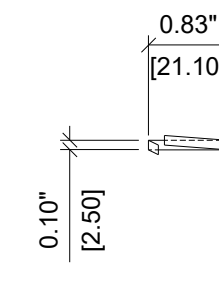

SIDE VIEW

Note:
T-BOLTS AND HARDWARE ARE METRIC SIZES. DIMENSIONS ARE CONVERTED TO IMPERIAL UNITS TO THE NEAREST TWO DECIMAL PLACES.

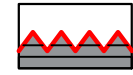

ITEM NUMBER: VARIES	CHANNEL LIP: SERRATED 
ITEM DESCRIPTION: HBC-B M12-T-BOLT, NUT & WASHERS	

