



The following pages are an excerpt from the North American Product Technical Guide, Volume 1: Direct Fastening Technical Guide, Edition 24.

Please refer to the publication in its entirety for complete details on this product including data development, base materials, general suitability, installation, corrosion, and product specifications.

[Direct Fastening Technical Guide, Edition 24](#)

To consult directly with a team member regarding our direct fastening products, contact Hilti's team of technical support specialists between the hours of 7:00am - 5:00pm CST.

US: 877-749-6337 or HNATechnicalServices@hilti.com

CA: 1-800-363-4458 ext. 6 or CATechnicalServices@hilti.com

3.2.10.1 Product description
 3.2.10.2 Material specifications
 3.2.10.3 Technical data
 3.2.10.4 Ordering information

3.2.10 SILL PLATE FASTENING SYSTEMS

3.2.10.1 PRODUCT DESCRIPTION

The 2-7/8" Hilti X-CF and X-CP fasteners are specifically designed for attaching wood sill plates to concrete substrates. Hilti offers a suitable fastener for most sill plate application conditions. The carbon steel thick coated X-CP 72 P8 S23 fastener complements the Hilti powder-actuated fastener portfolio specifically for sill plate applications where pressure treated lumber is being used.

The X-CP fasteners are suitable for use with pressure treated lumber sill plates. Reference General Guidelines on top of following page for fastener recommendation dependent on environment conditions and lumber type used. The X-CP fastener has a pre-mounted 0.905" (23 mm) 16 gauge washer for faster and more reliable installation. The X-CP fastener has an additional plastic washer that minimizes coating damage by the washer during installation. These sill plate fasteners are suitable for use with Hilti's powder-actuated tools and cartridges.

Product features:

- Fasteners for use with chemical pressure treated lumber (X-CP).
- Pre-assembled washer for faster and more reliable installation.
- Washer clearly stamped with material/coating for easier inspection.
- X-CP: Additional plastic insert to minimize coating damage during installation.

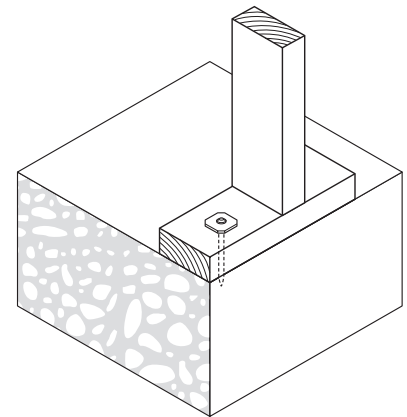
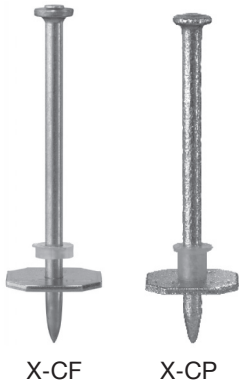

Listings/Approvals

ICC-ES (International Code Council)
 ESR-2379 with LABC/LARC Supplement





Installed X-CP fastener with "A 153" clearly marked on washer.

3.2.10.2 Material specifications

Fastener designation	Fastener material	Washer material	Fastener plating	Washer plating
X-CF 72 P8 S23	Carbon Steel	Carbon Steel	5 µm Zinc ¹	5 µm Zinc ¹
X-CP 72 P8 S23	Carbon Steel	Carbon Steel	Thick Mechanical Plated ² > 86 µm	Thick Mechanical Plated ² > 86 µm

¹ ASTM B633, SC 1, Type III. Refer to Section 2.3.3.1 for more information.
² Equivalent in corrosion resistance to ASTM A153 HDG. Refer to Section 2.3.3.1 for more information.

General guidelines for untreated and pressure-treated lumber^{1,2,3}

Environment	Indoor - dry: untreated lumber with no moisture exposure	Indoor and exterior - dry: pressure treated lumber with no moisture exposure
Wood type	Untreated lumber	SBX/DOT, Zinc borated ACQ, CA-B,CBA-A treated or untreated lumber
Fastener	Carbon Steel, electro-galvanized (min. 5 - 13 microns)	Carbon steel, thick mechanical plated (power driven fasteners > 86 microns)
Washer designation inspection	 X-CF washer	 X-CP washer denoting ASTM A153 corrosion resistance

- 1 If the moisture content of Pressure-Treated Lumber is high (> 18 %) or unknown, stainless steel fasteners are recommended. Select appropriate stainless steel grade for your application.
- 2 Guidelines based on fastener coating / material resistance to environmental corrosion (commonly called "rusting"). Evaluate site conditions which may affect these guidelines, such as: corrosive agents other than those listed; expected service life; other (non environmental) types of corrosion etc.
- 3 In highly corrosive environments (such as direct exposure to chlorides with average temperatures above 86 °F (30 °C)) it is generally recommended that a Highly Corrosive Resistant (HCR) Fastener be used such as Hilti HAS HCR Adhesive Anchor Rods. Contact Hilti Technical Support for more information.

3.2.10.3 TECHNICAL DATA

Allowable loads for sill plate fasteners installed in minimum $f'_c = 2,000$ psi normal weight concrete^{1,2,3}

Fastener designation	Shank diameter in. (mm)	Washer diameter in. (mm)	Fastener length in. (mm)	Tension lb (kN)	Shear lb (kN)
Interior shear wall or interior non-shear wall⁴					
X-CF 72 P8 S23	0.145 (3.7)	0.905 (23)	2-7/8 (72)	130 (0.58)	210 (0.93)
X-CP 72 P8 S23	0.145 (3.7)	0.905 (23)	2-7/8 (72)	175 (0.78)	250 (1.11)
Exterior Shear Wall⁵					
X-CF 72 P8 S23	0.145 (3.7)	0.905 (23)	2-7/8 (72)	130 (0.58)	165 (0.73)
X-CP 72 P8 S23	0.145 (3.7)	0.905 (23)	2-7/8 (72)	150 (0.73)	105 (0.42)

- 1 The tabulated allowable load values are for the low-velocity fasteners only, using a safety factor greater than or equal to 5.0, calculated in accordance with ICC-ES AC70. Wood sill plates connected to the substrate must be investigated in accordance with accepted design criteria.
- 2 Multiple fasteners are recommended for any attachment.
- 3 Allowable load values are for attachment of nominal 2x lumber with the steel washer bearing on the top surface of the wood.
- 4 These allowable load values based on testing performed at a minimum 3" edge distance (i.e. middle of slab).
- 5 These allowable load values based on testing performed at 1-3/4" edge distance.

3.2.10.4 ORDERING INFORMATION

Fastener description	Shank length in. (mm)	Shank Ø in. (mm)	Washer Ø in. (mm)	Packaging qty
Carbon steel - 5 µm zinc				
X-CF 72 P8 S23	2-7/8 (72)	0.145 (3.7)	0.905 (23)	100 pcs. / box
Carbon steel - thick mechanical plated > 86 µm				
X-CP 72 P8 S23	2-7/8 (72)	0.145 (3.7)	0.905 (23)	100 pcs. / box