



The following pages are an excerpt from the North American Product Technical Guide, Volume 1: Direct Fastening Technical Guide, Edition 24.

Please refer to the publication in its entirety for complete details on this product including data development, base materials, general suitability, installation, corrosion, and product specifications.

[Direct Fastening Technical Guide, Edition 24](#)

To consult directly with a team member regarding our direct fastening products, contact Hilti's team of technical support specialists between the hours of 7:00am - 5:00pm CST.

US: 877-749-6337 or [HNATechnicalServices@hilti.com](mailto:HNATechnicalServices@hilti.com)

CA: 1-800-363-4458 ext. 6 or [CATechnicalServices@hilti.com](mailto:CATechnicalServices@hilti.com)

## 3.5 STEEL DECK FASTENING SYSTEMS

### 3.5.1 STEEL DECK FASTENER DESIGN AND SELECTION

The following sections describe Hilti steel deck fastening solutions for the steel and metal trades. These solutions consist of powder-actuated and screw fastening systems which provide the installer with highly productive, high quality solutions which are designed to fit the needs of the particular application.

Hilti steel deck fastening systems are model code compliant alternatives to welds and offer many advantages to the building owner, designer and installer. Frame fastening systems consist of powder-actuated fasteners for attachment of a wide variety of steel deck profiles to structural steel and open web steel joists / bar joists or screw fasteners for attachment to bar joists or gauge purlins. Sidelap fastening systems consist of screw fasteners for attachment of steel deck panels to adjacent panels.

**X-HSN 24 Powder-Actuated and Racing Tip Screw Fastening Systems for bar joist or gauge purlin**

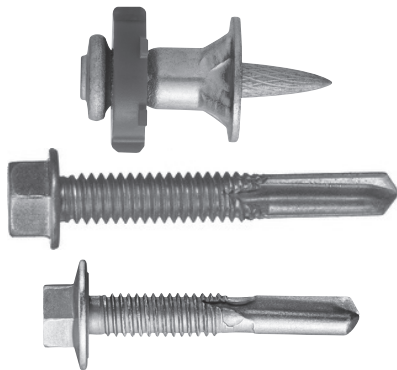

**X-ENP-19 Frame Fastener for structural steel**

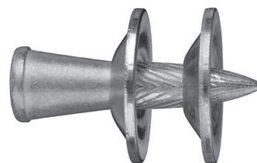

**SLC-01 and SLC-02 Sidelap Fasteners**

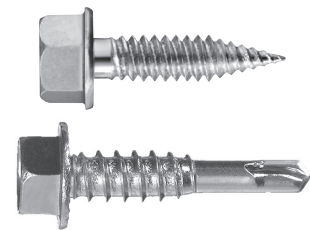

Hilti steel deck fastening systems have been extensively evaluated and hold all relevant model building code approvals and evaluations including International Code Council - Evaluation Service (ICC-ES), Steel Deck Institute (SDI), Los Angeles Department of Building and Safety (LADBS), Factory Mutual (FM), Underwriter's Laboratory (UL) and American Bureau of Shipping (ABS).

Please see the sections 3.5.2, 3.5.3, 3.5.4, 3.5.5 and 3.5.6 for more information on specific product approvals, evaluations and application limits.



In order to make selection and design with Hilti steel deck fasteners quicker and easier, Hilti developed the revolutionary Profis DF Diaphragm Software package. This design and submittal generator program incorporates a powerful design optimization feature to produce the most cost-effective and reliable steel deck design solutions. Producing project submittals including Hilti steel deck fasteners is also streamlined through an automatic design and submittal generator function. Visit the Hilti Decking Design Center to download your copy or ask your Hilti Field Engineer or Steel and Metal Account Manager for details today.



### 3.5.1.1 TERMINOLOGY AND DEFINITIONS

#### 3.5.1.1.1 Fastener terminology

<b>DX</b>	= Hilti terminology for direct fastening powder-actuated technology
<b>ENP</b>	= Hilti fastener type used for attaching steel deck to structural support steel with DX 76 and DX 9-ENP powder-actuated tools (X-ENP19 L15)
<b>F</b>	= diaphragm flexibility factor, micro-inch/lb (mm x 10 <sup>-6</sup> /N)
<b>G'</b>	= diaphragm shear stiffness lb/in. (N/mm x 10 <sup>-6</sup> )
<b>HSN</b>	= Hilti High Shear Nail fastener type for attaching steel deck to bar joist support steel used with DX 9-HSN and DX 5-SM powder-actuated tools (X-HSN 24)
<b>S<sub>n</sub></b>	= allowable diaphragm shear, plf (N/mm)
<b>P<sub>nf</sub></b>	= structural connector strength, lb (kN)
<b>P<sub>ns</sub></b>	= fastener strength, panel to panel, lb (kN)
<b>S<sub>f</sub></b>	= fastener flexibility factor, panel to frame, in./kip (mm/kN)
<b>S<sub>s</sub></b>	= fastener flexibility factor, panel to panel, in./kip (mm/kN)
<b>t<sub>f</sub>(t<sub>  </sub>)</b>	= flange thickness of beam or bar joist for steel deck applications, in. (mm)
<b>AISI</b>	= American Iron and Steel Institute
<b>ICC-ES</b>	= International Code Council - Evaluation Service
<b>SDI</b>	= Steel Deck Institute
<b>CSSBI</b>	= Canadian Sheet Steel Building Institute

#### 3.5.1.1.2 X-HVB Shear Connector terminology

<b>h<sub>r</sub></b>	= nominal rib height, in. (mm)
<b>H<sub>s</sub></b>	= connector height, in. (mm)
<b>N<sub>r</sub></b>	= number of connectors in one rib
<b>q</b>	= allowable shear strength, lb (kN)
<b>Q<sub>n</sub></b>	= nominal shear strength, lb (kN)
<b>R<sub>g</sub></b>	= coefficient to account for group effect
<b>w<sub>r</sub></b>	= average width of rib, in. (mm)
<b>Y<sub>con</sub></b>	= distance from top of steel beam to top of concrete slab, in. (mm)

#### 3.5.1.1.3 Steel deck definitions

<b>Base Material</b>	- The existing part of the work that is a base for the fastening. The structural steel or bar joist framing members in steel deck applications.
<b>Beam</b>	- One of the principal horizontal supporting members of a building.
<b>Burn through</b>	- Unintended welding-related holes created in steel deck.
<b>Button punch</b>	- A mechanical means of connecting two pieces of sheet metal together by crimping with a special tool. This method is used on BI or interlocking deck panels.
<b>Direct fastening</b>	- A fastening method in which the fastenings are made without any preparation steps such as drilling a hole. Examples are powder-actuated fastening and self-drilling screws.
<b>Diaphragm deck</b>	- A decking system which is designed to carry lateral loads due to wind or seismic action in addition to gravity loads and wind uplift.
<b>Endlap</b>	- The overlap of adjacent steel deck panels at the ends of the panels (end edges perpendicular to the steel deck panel fluting). Typically specified as 2 or 4 inches. Butted deck with no endlap is used for some steel deck (e.g., cellular).
<b>Fastener pattern</b>	- The number and spacing of fasteners at each support for a steel deck panel.
<b>Fastened material</b>	- The component that must be attached to the base or supporting material.
<b>Fastening</b>	- The combination of fastener, fastened material and base material all in final position.
<b>Fastening system</b>	- The fastener, fastening tool and driving power source all taken together as a system with specific performance characteristics.
<b>Gauge</b>	- A measure of thickness for sheet metal. Reference Section 3.5.1.6 for common steel deck gauges.
<b>Interlocking sidelap (BI connection)</b>	- Steel deck panels having male and female side edges. The adjacent deck panel male and female edges interlock into each other when the deck is installed. The interlocks are fastened together using button punches, proprietary punch systems, welds, or screws.
<b>Joist</b>	- A structural member in a building which is used to support a floor or roof.

**Nestable sidelap** - Steel deck type in which the side edge of a steel deck panel contains a partial valley profile and overlaps, or “nests” on top of the side edge of the adjacent steel deck panel, which contains a full valley profile. Often fastened together using self-drilling stitch screws.

**Non-diaphragm deck** - A steel deck system which is designed to carry only gravity loads.

**Powder-actuated cartridge** - A powder filled metal casing used as the source of driving energy in a powder-actuated tool. The ANSI A10.3 terminology for Hilti powder loads is a “cased powder load.”

**Powder-actuated fastener (PAF)** - A nail or threaded stud fastener capable of being driven into steel, concrete or masonry. Fasteners may be equipped with washers suitable for clamping the fastened material to the base or supporting material. Also referred to as Hilti DX, powder-actuated fasteners, power-driven fasteners (PDF), drive pins or shot pins.

**Low velocity powder-actuated tool** - A powder-actuated tool in which the expanding gas of the powder load acts on a captive piston, which in turn drives the fastener into the base material. If the average test velocity of the lightest fastener when using the strongest powder load does not exceed 328 fps (100 m/s), the tool meets the ANSI A10.3 requirements and is classified as a low-velocity tool. All Hilti powder-actuated tools used in the construction industry are classified as low-velocity.

**Profis DF Diaphragm Software** - Hilti developed, revolutionary design and submittal generator program. It incorporates a powerful design optimization feature to produce cost-effective and reliable steel deck solutions.

**Pullout** - As related to fasteners, a failure mode that occurs when the fastener pulls out of the base steel support.

**Pullover** - As related to fasteners, a failure mode that occurs when the steel deck panel pulls over the fastener head or washer(s).

**Punch systems** - A mechanical means of connecting two pieces of sheet metal together by punching through the steel to create a flap of metal which is then crimped. This is done with a proprietary pneumatic tool on interlocking deck panels.

**Purlin** - A secondary horizontal structural member attached to the primary frame and supporting the roof covering.

**Sidelap** - The side edge overlap of adjacent steel deck panels (side edges parallel to the steel deck panel fluting).

**Stitch screws** - Screws used to fasten the overlapping edges of two deck panels between joists or beams.

**Tack weld** - A weld of no structural significance. Used for temporary attachment of steel to the supporting frame. A weld made to hold the parts in proper alignment until the final welds are made.

**Uplift** - Vertical load on the steel deck panels due to wind forces.

**Wind tacking** - Limited fastening of the steel deck panel at the edges to hold the panels in place until all specified fastenings have been made.



### 3.5.1.2 STEEL DECK DIAPHRAGM DESIGN AND THEORY

#### 3.5.1.2.1 General discussion

A steel deck diaphragm is a horizontal assembly that resists wind, seismic and other lateral forces. A diaphragm can be modeled as a horizontal beam with interconnected floor and roof deck units that act as the beam web. Intermediate joists or beams act as web stiffeners and perimeter beams or reinforcement on the diaphragm perimeter act as the beam flanges. Figure 1, based on graphics from the Steel Deck Institute (SDI) Diaphragm Design Manual (DDM), depicts a roof deck diaphragm model.

Design of steel deck diaphragms can be done using the Steel Deck Institute (SDI) Diaphragm Design Manual (DDM) or American Iron and Steel Institute (AISI) S310. These methods provide the basic equations for determining the strength and stiffness of the diaphragm considering the following parameters:

1. Steel Deck Profile Type and Thickness
2. Supporting Steel Frame Spacing or Deck Span
3. Frame Fastener Type and Spacing (connector for steel deck to steel frame)
4. Sidelap Fastener Type and Spacing (connector for steel deck panel edge to edge)

5. Safety Factors (ASD) or Resistance Factors (LRFD/LSD) based on load type (wind, seismic, other) and fastening type (mechanical, weld)

ICC Evaluation Services (ICC-ES) recognizes the AISI S310 design methods as acceptable in AC43, "Acceptance Criteria for Steel Deck Roof and Floor Systems". An ICC Evaluation Service Report (ESR) based on ICC-ES AC43 provides recognition for use with the IBC. Hilti deck fasteners are currently listed in the SDI Deck Design Manual Version 04 (DDM04) and were evaluated in ICC-ES ESR-3693, ESR-2776 and ESR-2197. Hilti deck fastener performance with decking systems is also documented in ICC-ES ESR-1169, ESR-2635, ESR-2657 and IAPMO ER-0217, ER-2018, and ER-0329. Additional industry research has shown that metal deck systems, bare and filled, provide a high level of ductility and overstrength, when tested as part of a horizontal diaphragm. Metal deck fastened to the structure using specially designed Power-actuated fasteners perform especially well in absorbing excess energy in the inelastic range. The Steel Diaphragm Innovation Initiative, [www.steeli.org](http://www.steeli.org), has compiled a comprehensive report containing a database of small element and full scale static and cyclic tests.

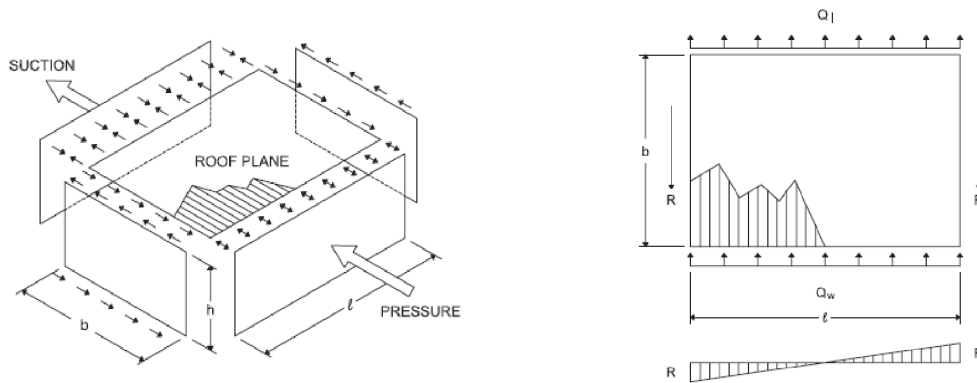

Figure 1: diaphragm model

#### 3.5.1.2.2 Fastener test programs

Many small element and full scale test programs have been conducted using Hilti deck fasteners to evaluate their performance.

##### 1. Small element connection tests

Small element connection tests are used to determine fastener pullout, pullover and lap-joint shear strength and stiffness with sheet steel and base steel representative of typical construction. The data is analyzed and used in a predictive model to calculate the performance of the larger steel deck diaphragm assembly or system. These tests are conducted in accordance with the following standards, and shown in Figure 2.

- AISI S905 Test Methods for Mechanically Fastened Cold-Formed Steel Connections
- ASTM E1190 Standard Test Methods for Strength of Power-Actuated Fasteners Installed In Structural Members
- ICC-ES AC70 Acceptance Criteria for Fasteners Power Driven Into Concrete, Steel and Masonry Elements
- ICC-ES AC118 Acceptance Criteria for Tapping Screw Fasteners

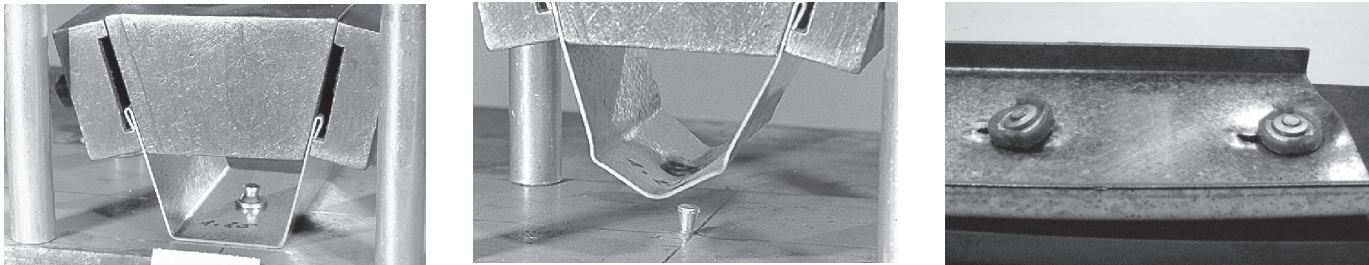

Figure 2: Small element connection tests

**2. Full scale diaphragm system tests (cantilever tests)**

Full scale diaphragm system tests are used to determine the strength and stiffness of a larger steel deck diaphragm assembly directly. The data is analyzed and fit in a predictive model to address varying configurations of base steel, steel deck, specific fastener combinations and spans. These tests are conducted in accordance with the following standards and shown in Figures 3, 4 and 5.

- ICC-ES AC43 Acceptance Criteria for Steel Deck Roof and Floor Systems
- AISI S907 Cantilever Test Method for Cold-Formed Steel Diaphragms
- ASTM E455 Standard Test Method for Static Load Testing of Framed Floor or Roof Diaphragm Constructions for Buildings

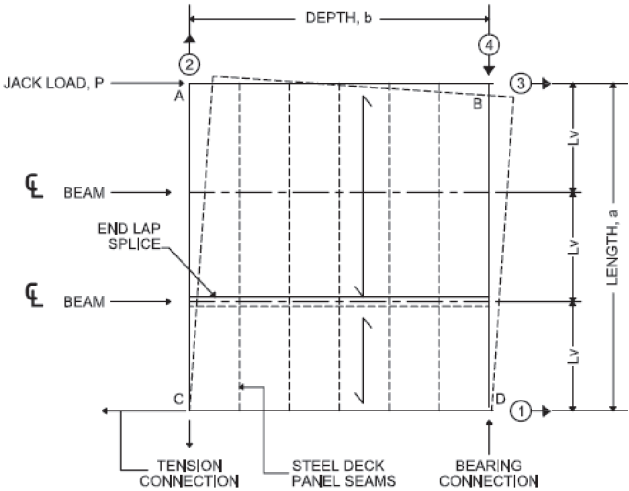
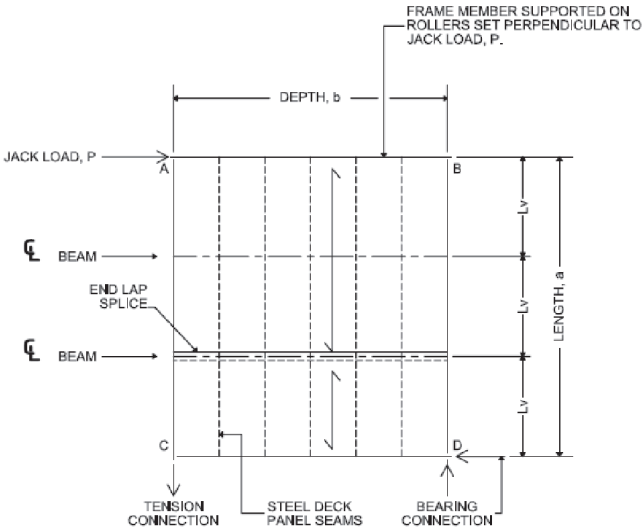

Figure 3: ICC-ES AC43 diaphragm test frame schematics

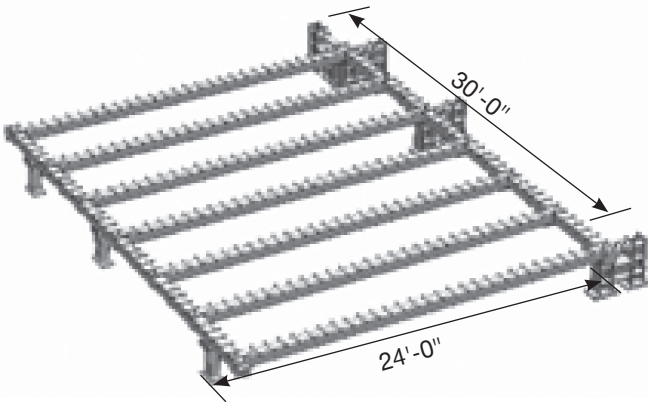
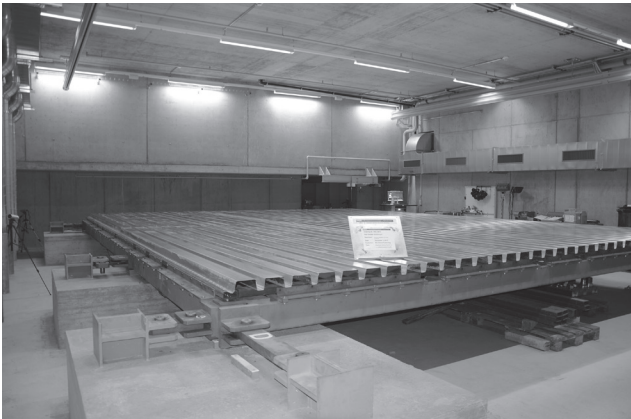

Figure 4: AC43 diaphragm test frame  
Fastening Systems Research Laboratory (FSRL), Schaan, Liechtenstein

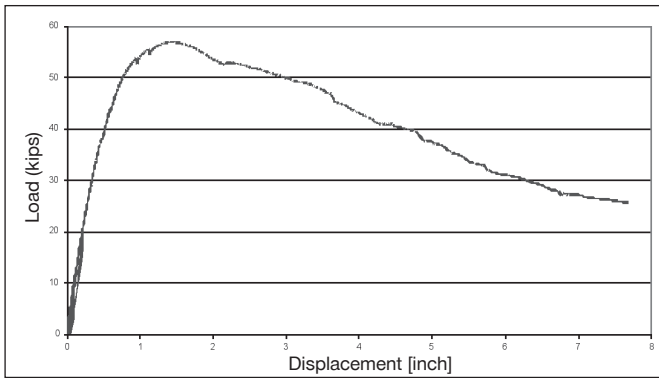

Figure 5: AC43 deck diaphragm load displacement curve

Hilti power-actuated deck fasteners are recognized alternatives to arc spot puddle welds and self-drilling screws. The fasteners can be used on roof deck diaphragms as well as composite concrete filled floor diaphragms. Hilti provides training for powder-actuated tool operators in accordance with ANSI A10.3 Safety Requirements for Powder-Actuated Fastening Systems.

**Hilti mechanical fastening systems provide superior solutions for attaching steel deck to steel support members**

- Consistent fastening quality
- High production rate
- No burn throughs or joist damage from welding
- Superior cyclic load performance and system ductility

**3.5.1.2.3 Proper fastener selection and steel deck layout (pre-fastener installation)**

Selection of the proper Hilti deck fastener depends on the supporting base steel thickness as shown in Section 3.5.1.3.1. The Hilti Deck Fastener Selection Gauge shown in Figure 6 should be used by the decking installer to confirm fastener selection. The cut-out slot on the gauge is fit against the bar joist top chord or steel beam flange. As the internal card slides in the gauge, the proper Hilti deck fastener is highlighted with a green box. A red box indicates that the corresponding Hilti deck fastener is outside the base material application limits and should not be used for steel deck fastening to the base material being gauged. Note that because of wide variations in base material hardness, on-site test installation is always required.

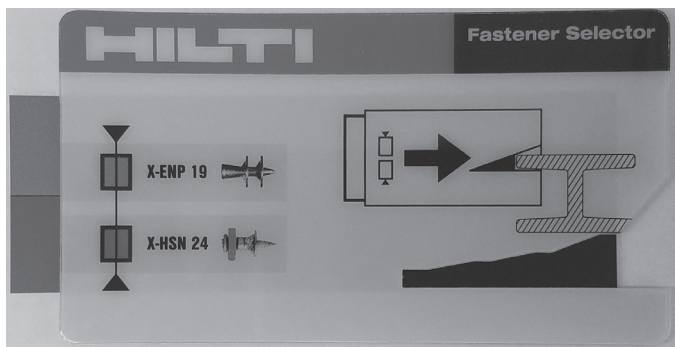

Figure 6: Hilti Deck Fastener Selection Gauge

Steel deck installers must layout deck properly and mark frame fastening lines in order to ensure that steel deck panels are connected to the supporting steel frame. Marking frame fastening lines is essential, especially when attaching steel deck to thin base steels ( $t_{II} < 1/4"$ ), including open web steel joists. For all applications, the fasteners should be installed at least  $3/8"$  (10 mm) from the edge or toe of the joist top chord or light steel beam flange. Additionally, when installing into a bar joist top chord (angle), the fasteners need to be installed at a distance from the angle,  $b_x \leq 8 \times t_{II}$ . Reference Figure 7 for edge distance and  $b_x$  dimensions.

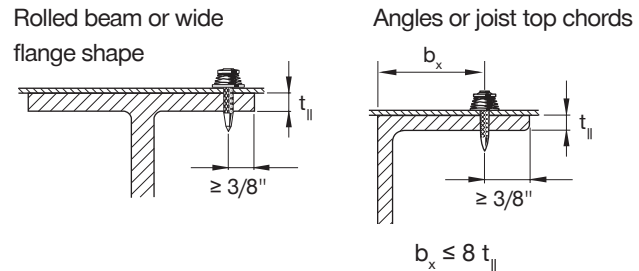

Figure 7: Edge distance recommendations

Extra care must be taken at the endlap and corner lap conditions where multiple layers of steel deck nest or interlock on adjacent panels. It is particularly important that endlap and corner lap conditions of two and four deck layers must be snug and tight against one another and the supporting steel frame in order for a proper fastening to be made as shown in Figure 8. Tight endlap and corner lap requirements are independent of the fastening type and contribute directly to the performance of arc spot welds, screws, power-actuated fasteners, punches and crimps/clinches. If the steel deck endlaps and corner laps are not tight, a proper fastening cannot be made.

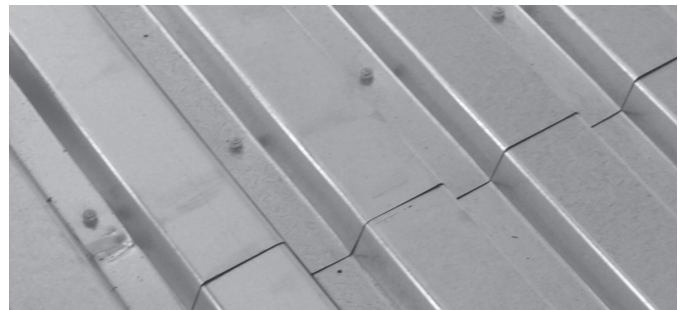

Figure 8: Tight nesting of steel deck sheets

### 3.5.1.2.4 Fastener inspection (post-fastener installation)

Steel deck construction projects may present a challenge with respect to the quality control of connections between sheet steel and the supporting steel structure. Quality control for traditional fastening methods may present a challenge as they typically consist of visual checks and dimensional or size verifications, which may or may not confirm a proper fastening. Field verification of the adequacy of power-actuated mechanical steel deck fastenings can be conducted as described in this section.

The use of mechanical fasteners does not imply a need to inspect every fastening point unless specified by the Structural Engineer. No guideline standards are published by SDI, AWS, AISC or OSHA for percentages of steel deck connections that must be checked or that can be unsatisfactory. This determination must be made by the Structural Engineer and Authority Having Jurisdiction.

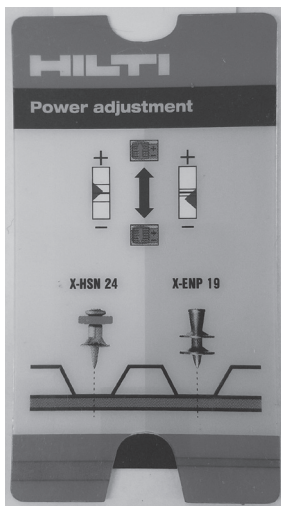

Figure 9:  
Hilti Power  
Adjustment Guide

Hilti has multiple systems in place that help ensure steel deck fastenings are done correctly the first time. Together with a commitment to field quality control by the steel deck installer, these systems may alleviate the need for post-fastener installation inspection. Hilti has over 1,000 Account Managers and Field Engineers available for training steel deck installers. This hands-on training includes the use of the Hilti Powder-Actuated Tools in accordance with ANSI A10.3 safety requirements, use of the Deck Fastener Selector Gauge, proper steel deck layout and end/corner lap nesting as discussed

in Section 3.5.1.2.3. Proper power-actuated fastener, tool and cartridge selection as discussed in Section 3.5.1.3, as well as the use of the Hilti Power Adjustment Guide, shown in Figure 9 and discussed in more detail in Section 3.5.1.3.3, are also key elements of the installer training. Furthermore, the Hilti DX9 -HSN tools come equipped with piston brakes, which virtually eliminate the possibility of overdriven fasteners, and punch-through if the base steel is missed.

There are three main characteristics of proper fastenings that must be considered:

**1. Fasteners installed in proper locations.** The fasteners must be installed in the proper steel deck valleys or flutes in accordance with the structural roof and floor deck plans and design, and in the proper location in the base steel (Reference Section 3.5.1.2.3). The fastener point must penetrate into, but not necessarily through, the supporting

steel (top chord or flange), depending on the fastener/deck/base steel configuration.

#### 2. Clamping of fastened part to base material.

The fasteners must clamp the steel deck down to the base steel (top chord or flange). There should not be any visible gaps between the steel deck and the base steel or between steel deck laps.

**3. Washer placement and condition.** In general, the fastener washer edges must be clamping the steel deck sheet to the base steel. The washers should not curl upwards away from the deck surface and must not be digging or cutting into the steel deck surface. For the X-HSN 24 fastener, the top hat washer must be compressed. For the X-ENP-19 fastener, the piston mark (indentation) should be clearly visible on the fastener washer as shown in Figure 10.

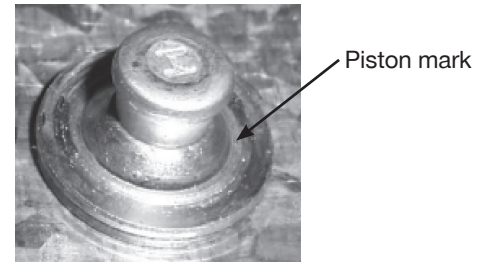

Figure 10: X-ENP-19 L15 piston mark (indentation)

When the compression of the top hat washer or the piston mark is unclear, the Hilti Power Adjustment Guide may be used to measure for optimal power-actuated fastener nailhead stand-off,  $h_{NVS}$ . Note that measuring nail head stand-off does not verify proper fastener embedment unless the steel deck and base material are tightly clamped, with the base steel not deformed or bent. Conversely, measuring nail head stand-off does not necessarily indicate an improper fastening. If slightly outside the range, further investigation into the three characteristics of proper fastenings given above should be completed.

The following Figures 11 and 12 provide visual examples of proper and improper steel deck fastenings for Hilti powder-actuated bar joist (X-HSN 24) and structural steel (X-ENP-19 L15) fasteners, respectively.

Inspection of the installed steel deck and installation of roof coverings, insulation and membrane should be done soon after steel deck installation to assist in alleviating corrosion or other issues that could arise due to long-term exposure.

Decking screws must be completely protected from the weather within 90 days after installation. Decking nails can be exposed to weather conditions for maximum 180 days. These standard values are only valid for typical atmospheric environments. Exposure time can be significantly affected by localized conditions like close distance to the sea, elevated temperatures and humidity, high levels of airborne pollutants, etc.



$h_{NVS}$  well above optimal range\*

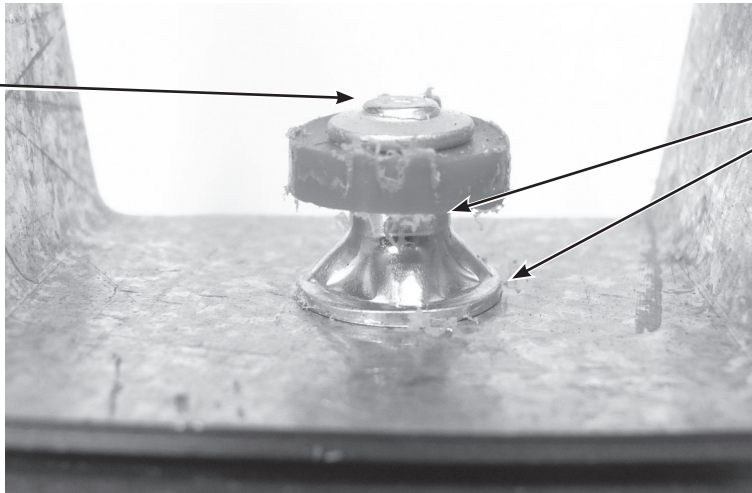

Top Hat not collapsed, not snug against steel deck and not clamping deck sheet to base steel

Figure 11a: Under driven X-HSN 24 fastener with single sheet to base steel

$h_{NVS}$  within optimal range\*

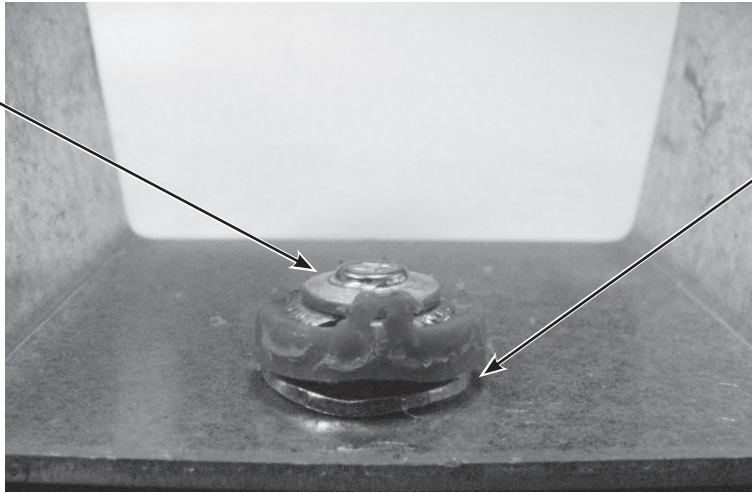

Top Hat properly collapsed, snug against steel deck and clamping deck sheet to base steel

Figure 11b: Properly driven X-HSN 24 fastener with single sheet to base steel

$h_{NVS}$  well below optimal range\*

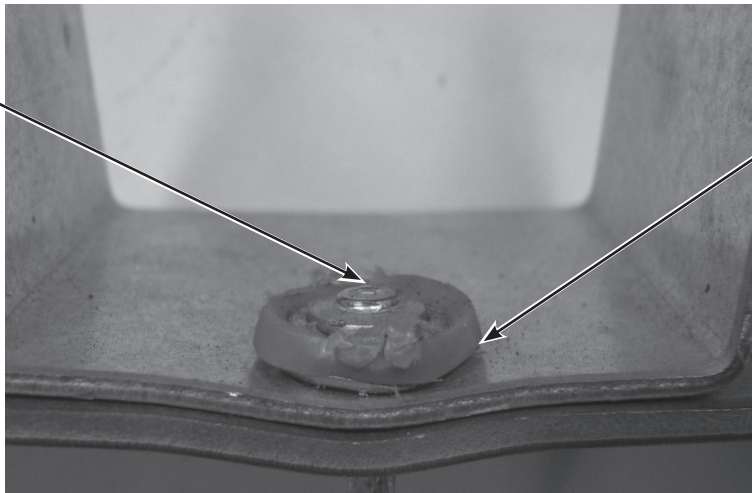

Washer cutting into deck sheet, deforming base steel and deck sheet

Figure 11c: Over driven X-HSN 24 fastener with single sheet to base steel

\* Optimal stand-off ( $h_{NVS}$ ) range for the X-HSN 24 fastener is  $5 \text{ mm} \leq h_{NVS} \leq 9 \text{ mm}$ .

$h_{NVS}$  well above optimal range\*

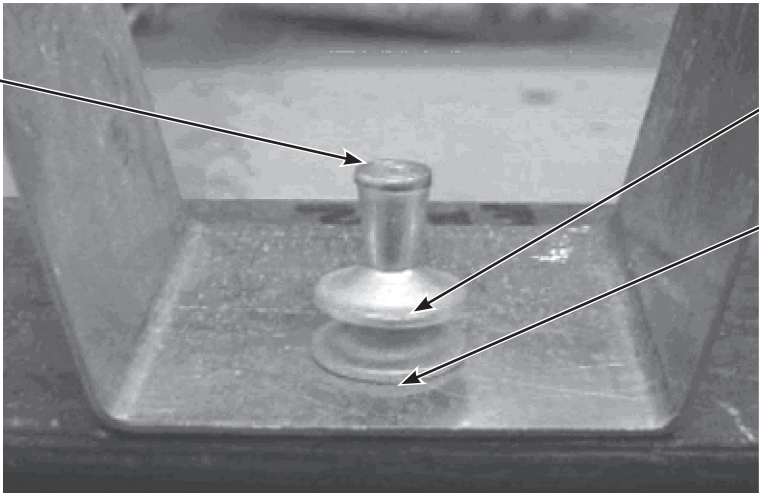

Piston mark (indentation) not visible on fastener  
Gap visible between washers  
Washers not clamping deck sheet to base steel

Figure 12a: Under driven X-ENP-19 fastener with single sheet to base steel.

$h_{NVS}$  within optimal range\*

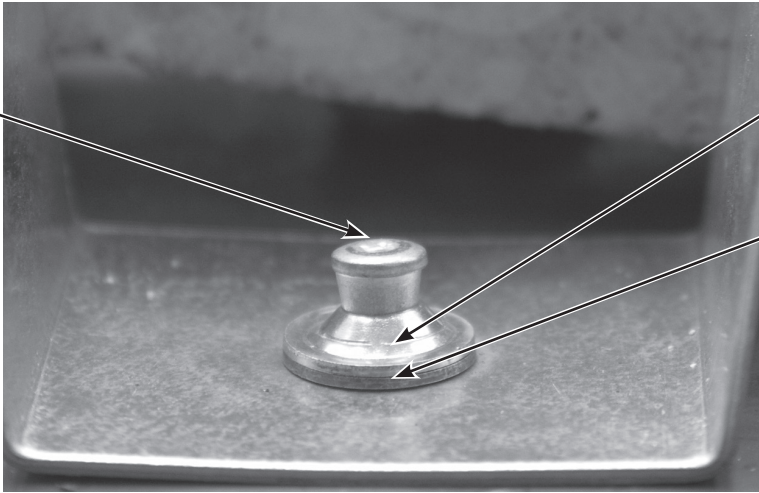

Piston mark (indentation) clearly visible on fastener  
Washers snug against one another and clamping deck sheet to base steel

Figure 12b: Properly driven X-ENP-19 fastener with single sheet to base steel

$h_{NVS}$  well below optimal range\*

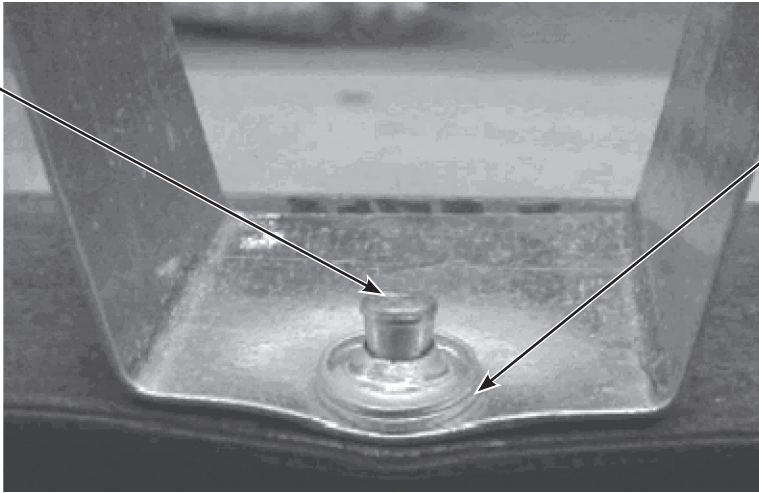

Washers cutting into deck sheet, deforming base steel and deck sheet

Figure 12c: Over driven X-ENP-19 fastener with single sheet to base steel

\* Optimal stand-off ( $h_{NVS}$ ) range for the X-ENP-19 fastener is  $8.2 \text{ mm} \leq h_{NVS} \leq 9.8 \text{ mm}$ .

### 3.5.1.3 FASTENER, TOOL AND CARTRIDGE SELECTION

#### Solutions for bar joist (open web joists) applications (Reference Section 3.5.2, 3.5.4 and 3.5.5)

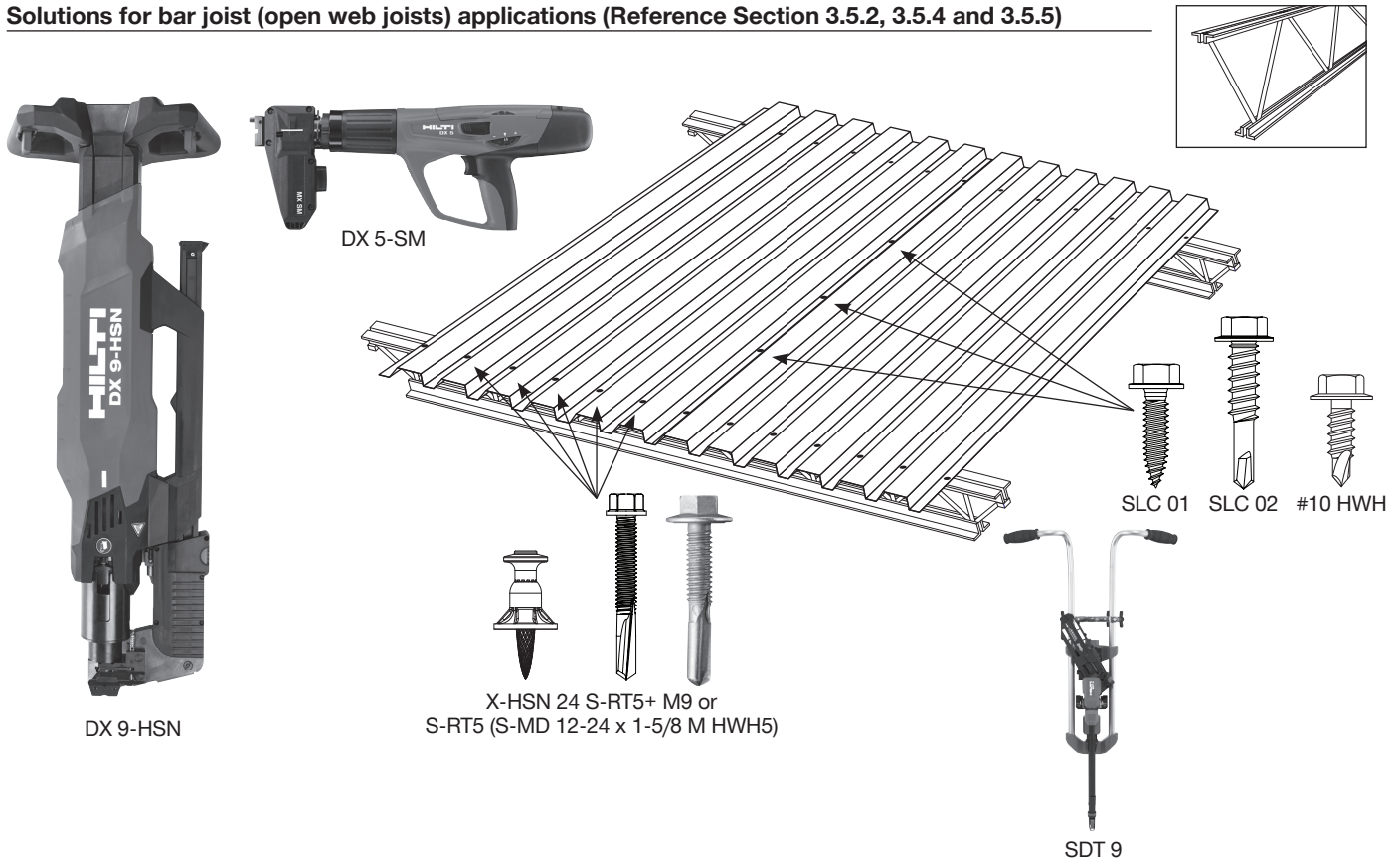

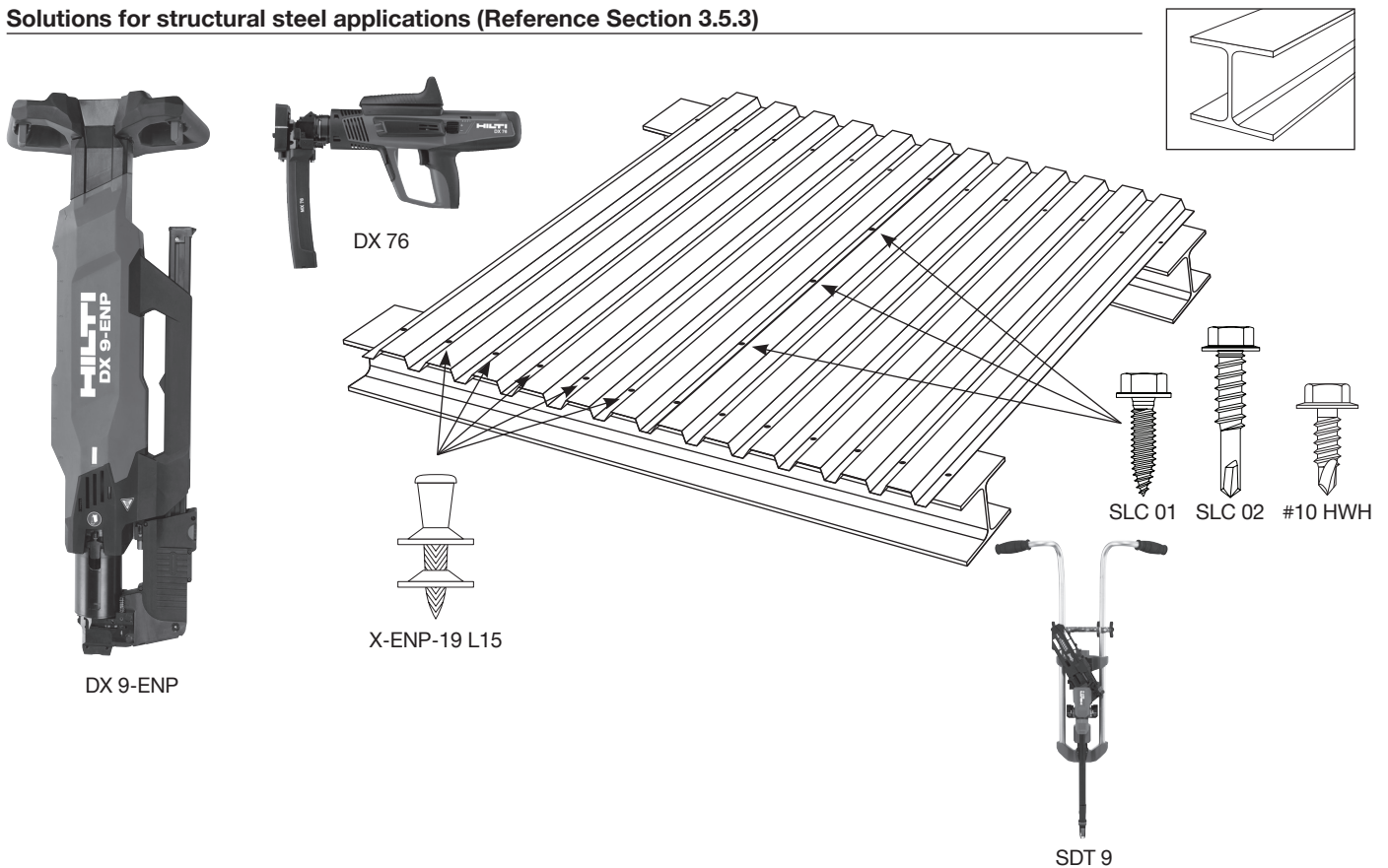

#### Solutions for structural steel applications (Reference Section 3.5.3)



3.5.1.3.1 Fastener selection

**Table 1 — Bar joist and light structural steel frame fasteners (Reference Section 3.5.2, 3.5.4 and 3.5.5)**

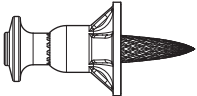

Base material <sup>1</sup>	Fastener type <sup>2</sup>	Recommended installation tool
Bar joist and structural steel $1/8'' (3 \text{ mm}) \leq t_f \leq 3/8'' (10 \text{ mm})$	<b>X-HSN 24</b> 	DX 9-HSN
	<b>S-RT5+ M9</b> 	SDT 9
Gauge purlin and light bar joist $0.0598'' (1.5 \text{ mm}) \leq t_f \leq 1/4'' (6 \text{ mm})$	<b>S-MD 12-24x1-5/8 M HWH5</b> 	SDT 9

- Steel base material strength ( $F_u$ ) shall be in the range of 58 to 91 ksi for base steel thicknesses ( $t_f$ ) less than or equal to  $5/16''$ . For base steel thicknesses greater than  $5/16''$ , the tensile strength shall be in the range of 58 to 75 ksi.
- The X-HSN 24 and Racing Tip Fastening Systems DO NOT fit in deck profiles Type A.

**Table 2 — Structural steel frame fasteners (Reference Section 3.5.3)**

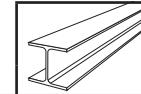

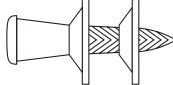
Base material <sup>1</sup>	Fastener type <sup>2</sup>	Recommended installation tool
Structural steel, hardened structural steel and heavy bar joist $t_f \geq 1/4'' (6 \text{ mm})$	<b>X-ENP-19 L15</b> 	DX 9-ENP

- Steel base material tensile strength ( $F_u$ ) shall be in a range of 58 to 91 ksi.
- X-ENP-19 L15 fasteners DO NOT fit in deck profiles Type A and Type F.

**Table 3 — Deck-to-deck sidelap fasteners (Reference Section 3.5.6)<sup>2</sup>**

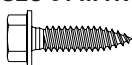
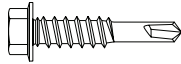
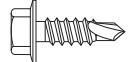
Deck gauges	Fastener Type <sup>1</sup>	Recommended installation tool
18 <sup>3</sup> to 26	<b>S-SLC 01 M HWH</b> 	SDT 9
18 to 22	<b>S-SLC 02 M HWH</b> 	SDT 9
16 <sup>4</sup> to 26	<b>Hilti #10 HWH Screw</b> 	SDT 9

- For use with all types of nestable deck or screwable interlocking deck.
- Other sidelap connector types are possible with Hilti's power actuated frame fasteners. Please reference the Steel Deck Institute (SDI) Diaphragm Design Manual 3rd Edition (DDM03).
- Use of S-SLC 01 M HWH with 18 gauge steel deck is recommended only for standard tensile strength ( $45 \leq F_u \leq 65 \text{ ksi}$ ) steel deck. For high tensile strength ( $F_u > 65 \text{ ksi}$ ) 18 gauge steel deck, use S-SLC 02 M HWH.
- Use of screws with full drill points recommended for 16 gauge steel deck.

**Sealing caps**

The SDK2 is an SAE 316 stainless steel sealing cap with a neoprene seal. This is installed over the head of the X-ENP-19 fastener using the SDK2 hand setting tool. The SDK2 sealing cap provides added corrosion protection for exposed exterior steel deck applications in accordance with IBC requirements.

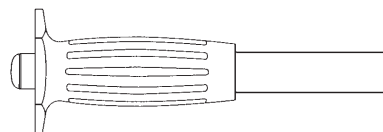

SDK2 Setting Tool

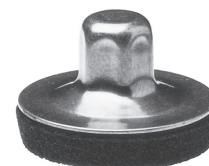

SDK2 Sealing Cap

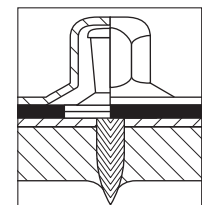

X-ENP-19 L15  
 $h_{nvs} = 8.2 \text{ mm} - 9.8 \text{ mm}$

Note: The sealing cap and fastener must be installed correctly to achieve a water-resistant seal. Contact Hilti for details.

### 3.5.1.3.2 Tool selection

#### Bar joist and light structural steel powder-actuated frame tools (Reference Section 3.5.2)

##### DX 9-HSN



The DX 9-HSN stand up decking tool is a digitally enabled fully automatic powder-actuated tool designed for attaching steel deck to bar-joist steel base materials. With a high fastening rate and 40-fastener magazine, the DX 9-HSN can significantly help reduce the time it takes to attach deck. Fastenings can be made on very thin support structures without the need for weld washers. Suitable for base steels with a thickness of 1/8" to 3/8". Fastens X-HSN 24 collated fasteners.



##### DX 5-SM



The DX 5-SM decking tool is a digitally enabled medium duty powder-actuated tool with adjustable power regulation used for attaching steel deck to bar-joist steel base materials. This system is best suited for deck with a flute width of 1/2" or greater and for base steels with a thickness of 3/16" to 3/8". Fastens X-HSN 24 collated fasteners.



#### Structural steel powder-actuated frame tools (Reference Section 3.5.3)

##### DX 9-ENP



The DX 9-ENP is a digitally enabled fully automatic powder-actuated tool designed for attaching steel deck to structural steel beams. The tool has capacity of 1 strip of 40 cartridges and 4 flexible strips of 10 each X-ENP-19 fasteners in an MXR collated configuration.

The DX 9-ENP is ergonomically designed to work in an upright position, and can be loaded without the operator bending over. The system is suitable for deck with a flute width of 3/4" or greater and base steels with a thickness of 1/4" or greater.



##### DX 76



The DX 76 decking system is a heavy duty fastening system consisting of semi-automatic, low-velocity powder-actuated tool, fasteners and cartridges for attaching steel deck to structural steel base materials. Special features include cartridge power regulation which allows for high productivity. This system is suitable for deck with a flute width of 3/4" or greater and base steels with a thickness of 1/4" or greater. Use with X-ENP-19 fasteners in single, MX or MXR collated configurations.



#### Gauge purlin and light bar joist screw frame tool and deck-to-deck sidelap fastening tool (Reference Section 3.5.4, 3.5.5 or 3.5.6)

##### SDT 9



The SDT 9 stand up decking tool is a steel deck sidelap and frame fastening tool. Combined with the DX 9-HSN or DX 9-ENP, these tools deliver a high speed, high productivity system for mechanical attachment of steel deck. The SDT 9 can consistently drive up to 50 S-MD 12-24x1-5/8 M HWH5 frame fasteners or SLC sidelap connectors before reloading. Its comfortable, durable design features an 18 position torque clutch to provide more consistent fastening quality. In a competitive market, the SDT 9 represents a major gain in productivity essential to staying on time and on budget.



3.5.1.3.3 Powder-actuated cartridge and power regulation selection

When installing powder-actuated deck fasteners, it is important for the installed fasteners to have a nailhead stand-off,  $h_{NVS}$ , within the specified range. The Hilti Power Adjustment Guide, shown in Figure 13, is a valuable quality assurance aid to the decking foreman. It is primarily intended for power adjustment of the powder-actuated tool. This is done by installing test fastenings into representative base steel and then checking the nailhead stand-off,  $h_{NVS}$ , at the beginning of the work to achieve the optimal cartridge and tool power level. This is a critical step in the work because of variations in the structural steel strengths ( $F_y$ ,  $F_u$ ) and member thicknesses. By investing time up front and properly correlating the fastening system to actual site materials, most fastening issues can be avoided. During installation, it is also advisable to check the work periodically to spot deficiencies before large portions of the deck might be fastened incorrectly. Failure to properly set the tool, fastener and cartridge prior to starting work can decrease fastening quality consistency.

Prior to starting work, the installer shall install a test fastening and check the  $h_{NVS}$  using the Hilti Power Adjustment Guide. If necessary, the installer shall adjust the power or force that drives the fastener into the base steel. There are two ways to accomplish this power adjustment. One is by use of different cartridge colors and the other is by adjusting the power regulator on the tool itself.

Cartridge colors available for Hilti decking tools are (in order of increasing power): yellow, blue, red and black. All Hilti decking tools come equipped with a power adjustment capability. The settings on the power regulation dials range from 1 to 4.

Figures 14 and 15 provide the installer with a recommended cartridge color and power setting for Hilti bar joist and structural steel deck fasteners, respectively. These charts are guidelines that the installer can use to start the process of test fastenings discussed above. This also helps ensure the installer will have the proper color cartridges on the project site.

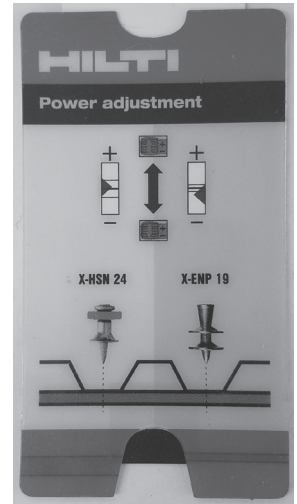

Figure 13: Hilti Power Adjustment Guide

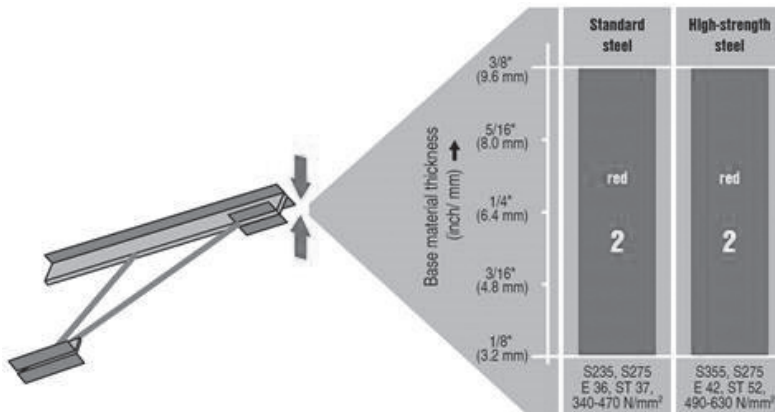

Figure 14: Cartridge and power regulation guidelines for bar joist deck fasteners installed with a DX 9-HSN<sup>1</sup>

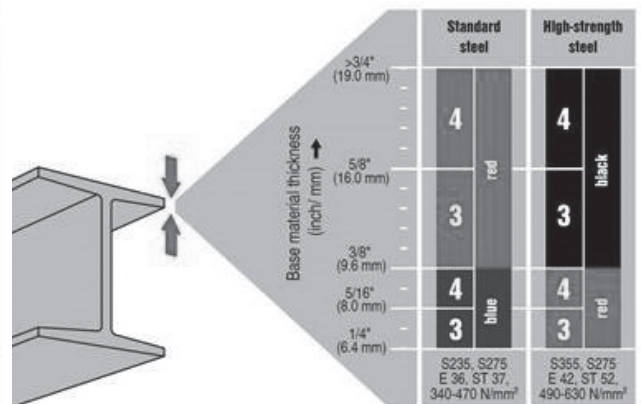

Figure 15: Cartridge and power regulation guidelines for structural steel deck fasteners<sup>1</sup>

<sup>1</sup> Cartridge recommendations for the X-ENP-19 fastener are acceptable for all current Hilti Decking Tools for attachment to structural steel. Cartridge recommendations for the X-HSN 24 fasteners are for the DX 9-HSN. Cartridge recommendations for the DX 5-SM can be found in the tool operator manual. **Recommendations are guidelines only and require verification on each site.**

3.5.1.4 SUBMITTAL INFORMATION FOR ROOF DECK

To download and submit Decking Submittal Forms and, please visit

<https://www.hilti.com/content/hilti/W1/US/en/engineering/design-centers/decking/decking-submittals.html>

### 3.5.1.5 FASTENER QUANTITY ESTIMATION

**Table 4 — Frame fasteners per square of roof<sup>1,2,3</sup>**

Fastener pattern	Fastener spacing	Support spacing, ft									
		4.0	4.5	5.0	5.5	6.0	6.5	7.0	8.0	9.0	10.0
36/14	6"	107	95	87	79	73	68	64	57	51	47
36/11	6"	81	72	66	60	56	52	48	43	39	36
36/9	6"	63	57	52	47	44	41	38	34	31	28
36/7	6"	55	49	45	41	38	35	33	30	27	25
36/5	6-12-12-6	37	33	31	28	26	24	23	21	19	17
36/4	12"	29	26	24	22	20	19	18	16	15	14
32/5	8"	42	37	34	31	29	27	25	23	21	19
32/3	16"	22	20	18	17	16	15	14	13	12	11
30/4	6-18-6	34	30	28	26	24	22	21	19	17	16
30/3	12-18	23	21	19	18	17	16	15	13	12	11
24/5	6"	55	49	45	41	38	35	33	30	27	25
24/3	6"	29	26	24	22	20	19	18	16	15	14
24/4	8"	42	37	34	31	29	27	25	23	21	19

1 Hilti Profis DF Diaphragm software also estimates fastener quantities.  
 2 Estimated quantities are for one square of decking. A square of roof decking is an area of 100 ft<sup>2</sup>. No provision is made for waste. Perimeter fastening spacing is based on 12" on-center assumption.  
 3 For interlocking sidelaps, add 15% to quantities in table.

### Sidelap fastener estimation

To estimate the number of sidelap screws on a steel roof or floor deck project, multiply the total deck area in square feet times the number of required stitch screws per span and then divide by the sheet width times the joist spacing (both in feet). A 5% contingency is also recommended for waste and loss.

**Example:**

Total area: . . . . . 50,000 square feet  
 Sheet width: . . . . . 36" = 3 ft  
 Joist spacing: . . . . . 5 ft  
 No. of sidelap fasteners per span: 5

$$\# \text{ of screws needed} = \frac{50,000 \text{ ft}^2}{3 \text{ ft} \times 5 \text{ ft}} \times 5 \times 1.05 = 17,500$$

### 3.5.1.6 COMMON STEEL DECK DIMENSIONS

**Table 5 — Common steel deck types and dimensions<sup>1,3</sup>**

Deck type	Common thickness	Standard dimensions
B	16-24 GA	
BI	16-24 GA	
N	16-22 GA	
N-32	16-22 GA	
F	18-22 GA	
Composite Deck	16-22 GA	
Form Deck	24-28 GA	

**Table 6 — Steel deck gauge (GA) inch and millimeter equivalent<sup>2,3</sup>**

Gauge (GA)	Nominal sheet steel thickness, t mils (mm)
16	54 (1.52)
18	43 (1.21)
20	33 (0.91)
22	27 (0.76)

1 Dimensions shown are typical. However, the Structural Engineer should always consult with the steel deck manufacturer on the dimensions for the specific product as they can vary depending on the manufacturer.  
 2 Deck gauge inch equivalents taken from SDI Diaphragm Design Manual. Millimeter equivalents taken from CSSBI Design of Steel Deck Diaphragms.  
 3 Calculations to produce diaphragm shear values with the deck profiles and gauges shown are possible with Hilti Profis DF Diaphragm software.

THE ABOVE FOOTNOTES APPLY TO TABLES 5 AND 6.

### 3.5.1.7 DIAPHRAGM SHEAR AND STIFFNESS CALCULATIONS

**Background:** An extensive independent laboratory test program was conducted investigating the performance of steel deck diaphragms attached with Hilti fasteners. The program test scope consisted of full scale diaphragm system tests conducted in accordance with ICC-ES AC43 and AISI S907, as well as comparative small element lap-joint shear tests conducted in accordance with AISI S905 Test Methods for Mechanically Fastened Cold-Formed Steel Connections. The resulting full scale and small element test data was analyzed and predictive equations were developed for the steel deck diaphragm system strength and stiffness using specific combinations of Hilti fasteners.

The American Iron and Steel Institute (AISI) Standard for the Design of Profiled Steel Diaphragm Panels (S310) method equations are used as the basis for determining the steel deck diaphragm strength and stiffness. Specific Hilti fastener strength and stiffness values and test data correlation adjustment factors were developed to provide 95% or greater accuracy with test results per ICC-ES AC43 requirements.

The resulting design information is documented in this section and in ICC-ES ESR-2776 and ESR-2197.

**Design:** Design equations for calculating steel deck diaphragm strength (S) and stiffness (G) or flexibility factor (F) with Hilti X-HSN 24, X-ENP-19 L15 or S-MD 12-24x1-5/8 M HWH5 (RT5) frame fasteners and Hilti Sidelap Connectors (SLC) are provided. The equation numbers in parenthesis correspond to the equation numbers provided in the AISI S310. The design equation variables needed for common steel deck diaphragm applications are found in Tables 7 through 9. The conversion factors for Allowable Stress Design (ASD), Load Resistance Factor Design (LRFD) and Limit States Design (LSD) provided in Table 11 shall be applied to the values determined from the design equations in order to produce the final Allowable Diaphragm Shear,  $S_{ASD}$  or Factored Resistance Diaphragm Shear,  $S_{LRFD}$  or  $S_{LSD}$ , respectively. The calculated  $S_{ASD}$ ,  $S_{LRFD}$  or  $S_{LSD}$  Diaphragm Shear values do not take into account steel deck buckling and must be checked against the appropriate buckling diaphragm shear value,  $S_{buckling}$ , found in Table 12. Reference Sections 3.5.2, 3.5.3, 3.5.4 and 3.5.5 for pre-calculated diaphragm shear and stiffness tables for the X-HSN 24, X-ENP-19, S-RT5+, and S-MD 12-24x1-5/8 M HWH5 fasteners, respectively.

The design equations and load values in this section are for 36" wide, 1-1/2" deep wide rib steel deck panels (B-Deck or BI-Deck types) and are limited to the fastener patterns shown in Figure 16 and sidelap connector spacings greater than 3" and in accordance with Table 10.

For other steel deck diaphragm conditions (e.g. deck profile, deck gauge, concrete-filled, etc.) not represented in the tables found in this section, use Hilti Profis DF Diaphragm software or reference ICC-ES ESR-2197.

#### AISI S310 steel deck diaphragm strength design equation

$$S_{ni} = [2 \times A \times (\lambda - 1) + \beta] \times \frac{P_{nf}}{L}, \text{ plf} \quad \text{Eq. D1-1}$$

$$S_{nc} = P_{nf} \times \sqrt{\frac{N^2 \times \beta^2}{L^2 \times N^2 + \beta^2}}, \text{ plf} \quad \text{Eq. D1-2}$$

$$S_{ne} = \frac{(2 \times \alpha_1 \times n_p \times \alpha_2) P_{nf} + n_e P_{nfs}}{L}, \text{ plf} \quad \text{Eq. D1-3}$$

$$S_{nf} = \min ( S_{ni}, S_{nc}, \text{ and } S_{ne} ), \text{ plf}$$

$$S_{nf} = c \times S_{nf}, \text{ plf}$$

with:

$$\beta = n_s \times \alpha_s + 2n_p X_p^2 + 4X_e^2$$

$$X_p^2 = \left( \frac{1}{w^2} \right) \sum x_p^2$$

$$X_e^2 = \left( \frac{1}{w^2} \right) \sum x_e^2$$

$$\lambda = 1 - \frac{D_d L_v}{240 \times \sqrt{t}} \geq 0.7 \quad \alpha_s = \frac{P_{ns}}{P_{nf}}$$

where:

t = nominal steel deck thickness, in. (Reference Table 6)

w = deck width

N = number of fasteners per unit length across the width, ft<sup>-1</sup>

$x_e = x_p$  = distance from panel centerline to any fastener in a panel at the end ( $x_e$ ) or purlin ( $x_p$ ) supports

S = nominal diaphragm shear strength, plf

L = span, ft      L = panel length = 3 x L, ft

$n_e = n_s = 3 \times L \times 12 \div$  (sidelap connector spacing in inches)

c = correlation factor for diaphragm system effect

Reference Tables 7 and 8 for description and values of other variables for common conditions.

**Uplift and combined loading:** Allowable loads to resist uplift forces are provided in the individual sections for each frame fastener. Reference SDI DDM04 Section 4.7 or Section D3 of AISI S310 for combined tension uplift and diaphragm shear interaction.





**AISI S310 steel deck diaphragm stiffness and flexibility factor design equations:**

$$G' = \left( \frac{Et}{2(1+\mu) \frac{s}{d} + \gamma_c D_n + C} \right) K = \left( \frac{Et}{3.78 + 0.9D + C} \right), \text{ kips/in.} \quad \text{Eq. D5.1.1-1}$$

$$F = \frac{1,000}{G'}$$

E = modulus of elasticity of steel = 29,500 ksi

$$D_n = \frac{D}{L} \quad \text{Eq. D5.1.1-1}$$

$$C = \left( \frac{Et}{w} \right) \left( \frac{2L}{2\alpha_3 + n_p \alpha_4 + 2n_s \frac{s_r}{s_s}} \right) S_f \quad \text{Eq. D5.1.1-2}$$

Reference Tables 7 and 9 for description and values of other variables for common conditions.

**Table 7 – Diaphragm strength (S) and stiffness factor (G') equation variable values<sup>1</sup>**

Deck type	Fastener pattern	$\alpha_1$ or $\alpha_3$ – end distribution factor	$\alpha_2$ or $\alpha_4$ – purlin distribution factor	$\sum x_{ee}^2$ or $\sum x_e^2$ , in. <sup>2</sup>	$\sum x_{pe}^2$ or $\sum x_{xp}^2$ , in. <sup>2</sup>	A	N, ft	D-Warping constant, in.			
								22 GA	20 GA	18 GA	16 GA
1-1/2" Wide Rib B- or BI-Deck	36/11	3.667	3.667	1,944	1,944	2	3.000	1,235	924	606	428
	36/9	3.000	3.000	1,656	1,656	2	2.333	1,235	924	606	428
	36/7	2.000	2.000	1,008	1,008	1	2.000	1,235	924	606	428
	36/5	1.667	1.667	936	936	1	1.333	7,288	5,452	3,578	2,525
	36/4	1.333	1.333	720	720	1	1.000	10,315	7,715	5,064	3,574
	36/3	1.000	1.000	648	648	1	0.667	21,217	15,871	10,417	7,315

<sup>1</sup> Reference ICC-ES ESR-2776 for Verco PLB deck and VSC2 sidelap connectors

Table 8 – Diaphragm strength (S) equation variable values

Configuration				Deck gauge (inches)								
				22 (0.0295)		20 (0.0358)		18 (0.0474)		16 (0.0598)		
Deck type <sup>3</sup>	Min. deck tensile (yield) strength, ksi	Frame fastener base material thickness, in.	Sidelap connector <sup>1,2</sup>	P <sub>nf</sub> , lb	P <sub>ns</sub> , lb	P <sub>nf</sub> , lb	P <sub>ns</sub> , lb	P <sub>nf</sub> , lb	P <sub>ns</sub> , lb	P <sub>nf</sub> , lb	P <sub>ns</sub> , lb	
				Correlation factor, c		Correlation factor, c		Correlation factor, c		Correlation factor, c		
B	65 (50) <sup>4</sup>	X-HSN 24 1/8 ≤ t <sub>f</sub> < 3/16	Hilti SLC	1357	844	1824	1260	1865	1701	-	-	
				1.184		1.201		1.233		-		
		X-HSN 24 3/16 ≤ t <sub>f</sub> ≤ 3/8	Hilti SLC	1590	844	2107	1260	2663	1701	3035	2024	
				1.149		1.127		1.087		1.044		
		X-ENP-19 t <sub>f</sub> ≥ 1/4	Hilti SLC	1597	844	2112	1260	2764	1701	3079	2024	
				1.315		1.259		1.156		1.046		
	65 (50) <sup>4</sup>	S-RT5+ M9 1/8 ≤ t <sub>f</sub> < 3/16	Hilti SLC	1357	844	1824	1260	1865	1701	-	-	
				1.184		1.201		1.233		-		
		S-RT5+ M9 3/16 ≤ t <sub>f</sub> ≤ 3/8	Hilti SLC	1590	844	2107	1260	2663	1701	3035	2024	
				1.149		1.127		1.087		1.044		
		S-RT5+ M9 1/8 ≤ t <sub>f</sub> < 3/16	Hilti #10 HWH Screw	1489	598 <sup>5</sup>	1795	799 <sup>5</sup>	2348	1217 <sup>5</sup>	-	-	
				1.000		1.000		1.000		-		
S-RT5+ M9 3/16 ≤ t <sub>f</sub> ≤ 3/8	Hilti #10 HWH Screw	1489	598 <sup>5</sup>	1795	799 <sup>5</sup>	2348	1217 <sup>5</sup>	2924	1725 <sup>5</sup>			
		1.000		1.000		1.000		1.000				
92 (80)	X-HSN 24 1/8 ≤ t <sub>f</sub> < 3/16	Hilti SLC	1357	844	1712	1111	1865	1701	-	-		
			1.155		1.172		1.203		-			
	X-HSN 24 3/16 ≤ t <sub>f</sub> ≤ 3/8	Hilti SLC	1941	954	2208	1341	2698	1859	3095	2343		
			1.052		1.054		1.058		1.062			
X-ENP-19 t <sub>f</sub> ≥ 1/4	Hilti SLC	1964	954	2165	1341	3022	1859	3577	2343			
		1.197		1.166		1.108		1.046				
BI	65 (50) <sup>4</sup>	X-HSN 24 1/8 ≤ t <sub>f</sub> < 3/16	Hilti SLC	1357	844	1712	1111	1865	1591	-	-	
				1.184		1.201		1.233		-		
		X-HSN 24 3/16 ≤ t <sub>f</sub> ≤ 3/8	Hilti SLC	1516	882	1712	1111	2450	1591	2553	2051	
				1.316		1.264		1.168		1.066		
		65 (50) <sup>4</sup>	S-RT5+ M9 1/8 ≤ t <sub>f</sub> < 3/16	Hilti SLC	1357	844	1712	1111	1865	1591	-	-
					1.184		1.201		1.233		-	
	S-RT5+ M9 3/16 ≤ t <sub>f</sub> ≤ 3/8		Hilti SLC	1516	882	1712	1111	2450	1591	2553	2051	
				1.316		1.264		1.168		1.066		
	S-RT5+ M9 1/8 ≤ t <sub>f</sub> < 3/16		Hilti #10 HWH Screw	1489	598 <sup>5</sup>	1795	799 <sup>5</sup>	2348	1217 <sup>5</sup>	-	-	
				1.000		1.000		1.000		-		
	S-RT5+ M9 3/16 ≤ t <sub>f</sub> ≤ 3/8	Hilti #10 HWH Screw	1489	598 <sup>5</sup>	1795	799 <sup>5</sup>	2348	1217 <sup>5</sup>	2924	1725 <sup>5</sup>		
			1.000		1.000		1.000		1.000			
B or BI	45 or 92 (33 or 80)	S-MD 12-24x1-5/8 M HWH5 0.0598 ≤ t <sub>f</sub> < 1/8	Hilti SLC	1016	844	1233	1260	1632	1701	1860	2024	
				1.000		1.000		1.000		1.000		
		S-MD 12-24x1-5/8 M HWH5 1/8 ≤ t <sub>f</sub> ≤ 1/4	Hilti SLC	1193	844	1661	1260	1860	1701	1860	2024	
				1.000		1.000		1.000		1.000		
		X-HSN 24 1/8 ≤ t <sub>f</sub> ≤ 3/8	Hilti #10 HWH Screw	1489	598 <sup>5</sup>	1795	799 <sup>5</sup>	2348	1217 <sup>5</sup>	2924	1725 <sup>5</sup>	
				1.000		1.000		1.000		1.000		
		X-ENP-19 t <sub>f</sub> ≥ 1/4	Hilti #10 HWH Screw	1603	598 <sup>5</sup>	1933	799 <sup>5</sup>	2529	1217 <sup>5</sup>	3149	1725 <sup>5</sup>	
				1.000		1.000		1.000		1.000		
S-MD 12-24x1-5/8 M HWH5 0.0598 ≤ t <sub>f</sub> ≤ 1/4	Hilti #10 HWH Screw	1193	633	1661	769	1860	1018	1860	1284			
		1.000		1.000		1.000		1.000				

1 Sidelap connector spacing must meet the requirements of Table 10.  
 2 Reference Table 3 and Section 3.5.6 for more information on the proper selection of Hilti Sidelap Connectors (SLC).  
 3 Reference ICC-ES ESR-2776 for Verco PLB deck and VSC2 sidelap connectors  
 4 For steel deck with minimum deck strength of 55 (40) Tensile, F<sub>u</sub>, (Yield, F<sub>y</sub>) ksi, the corresponding correlation factors (c) must be calculated by applying a reduction factor of 0.989.  
 5 For steel deck with minimum deck strength of 55 (40) Tensile, F<sub>u</sub>, (Yield, F<sub>y</sub>) ksi, the corresponding sidelap connector strength must be calculated by applying a reduction factor of 0.85.

**Table 9 – Diaphragm stiffness (G') and flexibility factor (F) equation variable values**

Configuration				Deck gauge (inches)			
				22 (0.0295)	20 (0.0358)	18 (0.0474)	16 (0.0598)
Deck type <sup>2</sup>	Min. deck tensile (yield) strength, ksi	Frame fastener	Sidelap connector <sup>1</sup>	S <sub>p</sub> , in./kip	S <sub>p</sub> , in./kip	S <sub>p</sub> , in./kip	S <sub>p</sub> , in./kip
				S <sub>s</sub> , in./kip	S <sub>s</sub> , in./kip	S <sub>s</sub> , in./kip	S <sub>s</sub> , in./kip
B or BI	45 or 92 (33 or 80)	X-HSN 24 or S-RT5+ M9	Hilti SLC or Hilti #10 HWH Screw	0.0073	0.0066	0.0057	0.0051
				0.0175	0.0159	0.0138	0.0123
		X-ENP-19	Hilti SLC or Hilti #10 HWH Screw	0.0044	0.0040	0.0034	0.0030
				0.0175	0.0159	0.0138	0.0123
		S-MD 12-24x1-5/8 M HWH5	Hilti SLC or Hilti #10 HWH Screw	0.0076	0.0069	0.0060	0.0053
				0.0175	0.0159	0.0138	0.0123

1 Reference Table 3 and Section 3.5.6 for more information on the proper selection of Hilti Sidelap Connectors (SLC).

2 Reference ICC-ES ESR-2776 for Verco PLB deck and VSC2 sidelap connectors.

**Table 10 – Minimum recommended sidelap connector spacing (Inches center-to-center) for X-HSN 24 and X-ENP-19 powder-actuated fasteners with B-Deck or BI-Deck type**

Frame fastener base material thickness, in.	Deck gauge	Frame fastener pattern											
		36/3		36/4		36/5		36/7		36/9 <sup>2</sup>		36/11 <sup>2</sup>	
		SLC <sup>1</sup>	#10	SLC <sup>1</sup>	#10	SLC <sup>1</sup>	#10	SLC <sup>1</sup>	#10	SLC <sup>1</sup>	#10	SLC <sup>1</sup>	#10
X-HSN 24 1/8 ≤ t <sub>f</sub> < 3/16	22	-	-	≥ 12	≥ 6	≥ 12	≥ 6	≥ 6	≥ 3	≥ 6	≥ 3	≥ 6	≥ 3
	20	-	-	≥ 12	≥ 6	≥ 12	≥ 6	≥ 6	≥ 3	≥ 6	≥ 3	≥ 6	≥ 3
	18	-	-	-	-	-	-	-	-	-	-	-	-
	16	-	-	-	-	-	-	-	-	-	-	-	-
X-HSN 24 3/16 ≤ t <sub>f</sub> ≤ 3/8	22	≥ 12	≥ 3	-	-	-	-	-	-	-	-	-	-
	20	≥ 12	≥ 3	≥ 6	≥ 3	≥ 6	≥ 3	≥ 3	≥ 3	≥ 3	≥ 3	≥ 3	≥ 3
	18	-	-	-	-	-	-	-	-	-	-	-	-
	16	-	-	-	-	-	-	-	-	-	-	-	-
X-ENP-19 t <sub>f</sub> ≥ 1/4	22	≥ 6	≥ 3	≥ 6	≥ 3	≥ 6	≥ 3	≥ 3	≥ 3	≥ 3	≥ 3	≥ 3	≥ 3
	20	≥ 6	≥ 3	≥ 6	≥ 3	≥ 6	≥ 3	≥ 3	≥ 3	≥ 3	≥ 3	≥ 3	≥ 3
	18	≥ 6	≥ 3	≥ 6	≥ 3	≥ 6	≥ 3	≥ 3	≥ 3	≥ 3	≥ 3	≥ 3	≥ 3
	16	≥ 6	≥ 3	≥ 6	≥ 3	≥ 6	≥ 3	≥ 3	≥ 3	≥ 3	≥ 3	≥ 3	≥ 3

1 Hilti SLC spacings less than those tabulated may be used. The tabulated spacing should be used in the calculation of diaphragm shear strength when using the P<sub>nf</sub>, P<sub>ns</sub> and c values from Table 8. Alternatively, only when the SLC spacings are less than those tabulated, the P<sub>nf</sub>, P<sub>ns</sub> and c values found in Table 8 can be replaced by the following values.

X-HSN 24 – All deck types, strengths and base steel thicknesses listed in Table 8

22 Gauge (0.0295 in.) - P<sub>nf</sub> = 1489 lb, P<sub>ns</sub> = 716 lb, c = 1.000

20 Gauge (0.0358 in.) - P<sub>nf</sub> = 1795 lb, P<sub>ns</sub> = 869 lb, c = 1.000

18 Gauge (0.0474 in.) - P<sub>nf</sub> = 2348 lb, P<sub>ns</sub> = 1151 lb, c = 1.000

16 Gauge (0.0598 in.) - P<sub>nf</sub> = 2924 lb, P<sub>ns</sub> = 1452 lb, c = 1.000

2 For 36/9 and 36/11 patterns, when wind (or seismic) diaphragm shear capacities exceed the values shown below, the fastening pattern must be increased at the building perimeter, chords, collectors or other shear transfer elements to two fasteners per rib (i.e. 36/14 pattern). The wind (or seismic) diaphragm shear capacity must not be greater than that determined from the 36/9 and 36/11 patterns, as applicable.

X-HSN 24 with steel support framing thicknesses 1/8" ≤ t<sub>f</sub> < 3/16"

	ASD wind (seismic)	LRFD wind (seismic)	LSD wind (seismic)
22 Gauge (0.0295 in.) -	1275 plf (1200 plf)	2100 plf (1950 plf)	28.5 N/mm (26.3 N/mm)
20 Gauge (0.0358 in.) -	1600 plf (1500 plf)	2625 plf (2450 plf)	35.8 N/mm (32.8 N/mm)
18 Gauge (0.0474 in.) -	1825 plf (1700 plf)	3000 plf (2675 plf)	39.0 N/mm (37.2 N/mm)

X-HSN 24 with steel support framing thicknesses 3/16" ≤ t<sub>f</sub> ≤ 3/8"

	ASD wind (seismic)	LRFD wind (seismic)	LSD wind (seismic)
22 Gauge (0.0295 in.) -	1400 plf (1300 plf)	2300 plf (2125 plf)	31.0 N/mm (28.8 N/mm)
20 Gauge (0.0358 in.) -	1700 plf (1600 plf)	2800 plf (2600 plf)	37.9 N/mm (35.0 N/mm)
18 Gauge (0.0474 in.) -	2250 plf (2100 plf)	3700 plf (3425 plf)	50.0 N/mm (46.3 N/mm)
16 Gauge (0.0598 in.) -	2775 plf (2600 plf)	4550 plf (4225 plf)	61.7 N/mm (56.9 N/mm)

**Table 11 – Safety factors for allowable stress design (ASD), load resistance factor design (LRFD) and limit states design (LSD)<sup>1,2</sup>**

Load type or combinations	Frame fastener	Connection related limit state		
		Ω (ASD)	Φ (LRFD)	Φ (LSD)
Wind	X-HSN 24 or X-ENP-19 L15	2.00	0.80	0.75
Earthquake and all others		2.30	0.70	0.55
Wind	S-RT5 + M9	2.00	0.80	0.75
Earthquake and all others		2.30	0.70	0.55
Wind	S-MD 12-24 x 1-5/8 M HWH5	2.00	0.80	0.75
Earthquake and all others		2.30	0.70	0.55

1 Safety factors based on AISI S310-13 and -16  
 2 Diaphragm capacities should be limited to the respective ASD, LRFD and LSD buckling diaphragm shear capacities found in Table 12

**Table 12 – ASD and LRFD diaphragm shears (plf) and LSD diaphragm shears (N/mm) for buckling,  $S_{buckling}$ <sup>1,2</sup>**

Deck type	Deck gauge no.	Minimum moment of inertia, $I_{xg}$ in <sup>4</sup> /ft	Span, $L_v$ (ft-in.)									
			3'-0"	4'-0"	5'-0"	6'-0"	7'-0"	8'-0"	9'-0"	10'-0"	11'-0"	12'-0"
<b>ASD – <math>S_{nb}/\Omega_{nb}</math> where <math>\Omega_{nb} = 2.00</math></b>												
B, BI, and Vercor PLB	22	0.173	7,750	4,360	2,790	1,938	1,424	1,090	861	698	576	484
	20	0.210	10,363	5,829	3,731	2,591	1,903	1,457	1,151	933	771	648
	18	0.279	15,829	8,904	5,698	3,957	2,907	2,226	1,759	1,425	1,177	989
	16	0.353	22,479	12,644	8,092	5,620	4,129	3,161	2,498	2,023	1,672	1,405
<b>LRFD - <math>\Phi S_{nb}</math> where <math>\Phi_{nb} = 0.80</math></b>												
B, BI, and Vercor PLB	22	0.173	12,401	6,975	4,464	3,100	2,278	1,744	1,378	1,116	922	775
	20	0.210	16,581	9,327	5,969	4,145	3,046	2,332	1,842	1,492	1,233	1,036
	18	0.279	25,327	14,246	9,118	6,332	4,652	3,562	2,814	2,279	1,884	1,583
	16	0.353	35,966	20,231	12,948	8,992	6,606	5,058	3,996	3,237	2,675	2,248
Steel deck type	Deck gauge no.	Moment of inertia, $I_{xg}$ in <sup>4</sup> /ft	Span, $L_v$ (mm)									
			900	1200	1500	1800	2100	2400	2700	3000	3300	3600
<b>LSD (N/mm)</b>												
Standard 1-1/2-inch deep flutes, 6-inches center-to-center	22	208	192.6	108.3	69.3	48.1	35.4	27.1	21.4	17.3	14.3	12.0
	20	270	250.0	140.6	90.0	62.5	45.9	35.2	27.8	22.5	18.6	15.6
	18	388	359.3	202.1	129.3	89.8	66.0	50.5	39.9	32.3	26.7	22.5
	16	485	449.1	252.6	161.7	112.3	82.5	63.2	49.9	40.4	33.4	28.1

1 Load values based upon a safety factor (Ω) of 2.00 for ASD, a phi factor (Φ) of 0.80 for LRFD or a phi factor (Φ) of 0.75 for LSD.  
 2 Diaphragm shears in this table are for steel deck buckling failure mode only and are to be used as prescribed in Section 3.5.1.7. If design condition is not tabulated, diaphragm shears for buckling may be calculated using the following equations:  
 For ASD,  $S_{buckling} = (1 \times 10^6 / (L_v)^2) / 2.0$ , plf  
 For LRFD,  $S_{buckling} = (1 \times 10^6 / (L_v)^2) \times 0.8$ , plf  
 For LSD,  $S_{buckling} = (1 \times 10^6 / (L_v)^2) \times 0.75$ , N/mm

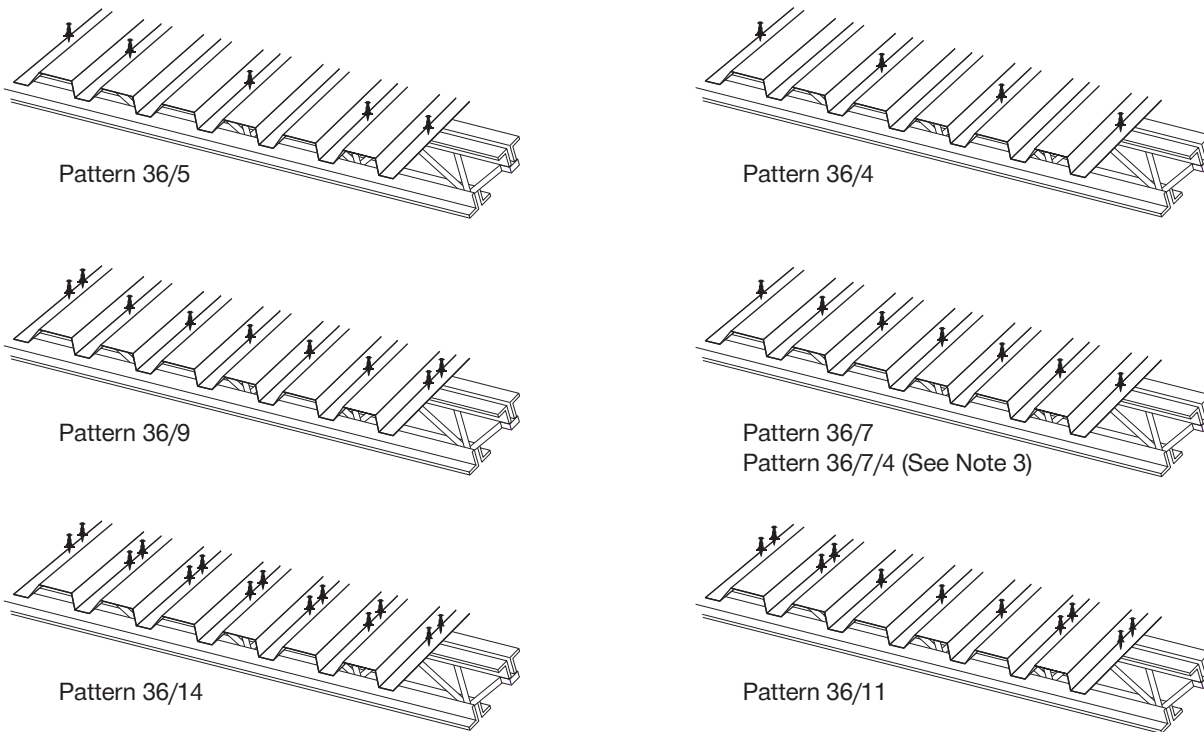

Note 1: Nestable B-Deck shown. Interlocking BI-Deck with screwable sidelap is also covered by the equations discussed in Section 3.5.1.7.  
 Note 2: Bar joist shown. Connection to structural steel members also covered by the equations discussed in Section 3.5.1.7.  
 Note 3: 36/7/4 attachment pattern utilizes 36/7 attachment at panel lap and panel end lap, 36/4 attachment at panel intermediate supports

Figure 16: Common frame fastener patterns

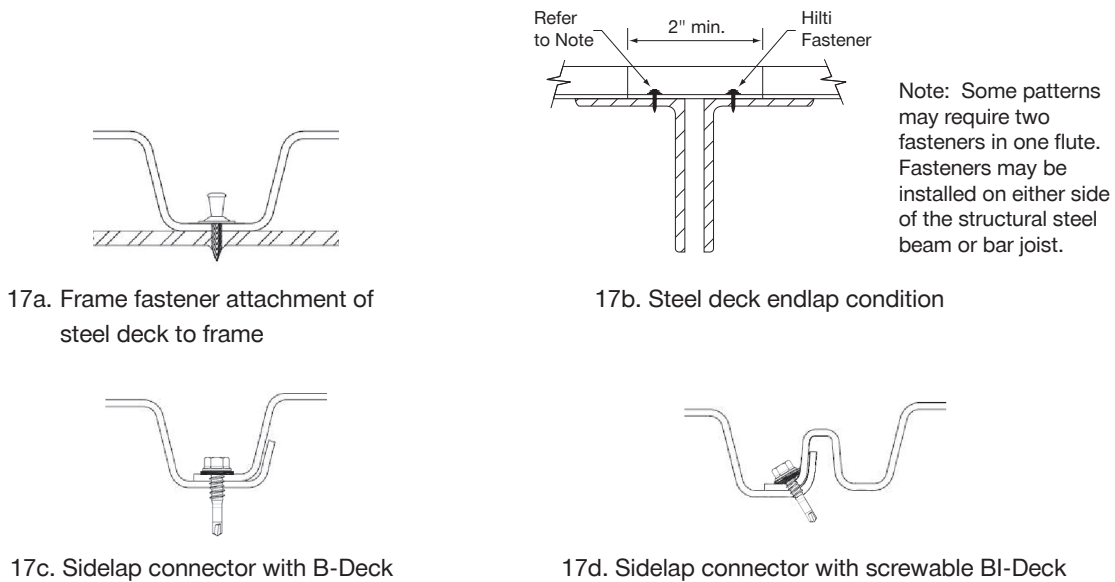
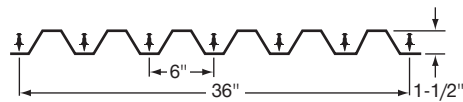

Figure 17: Typical frame, endlap and sidelap connections

**Example problem**

**Design parameters:**

Load type: Wind  
 Design method: ASD  
 Span,  $L_v$ : 6'-0"  
 No. of Spans: 3  
 Total Length, L: 18'-0"  
 Deck: No. 20 gage (0.0358 inch)  
 1-1/2" deep B-Deck ( $F_y = 50$  ksi)  
 Support Framing: Steel Bar Joist with 1/4" Thick Top Chord  
 Frame Fastener: X-HSN 24  
 Frame Fastener Pattern: 36/7  
 Sidelap Fastener: Hilti SLC  
 Sidelap fastener spacing (SS): 12" o.c.



**Design problem:**

Determine Allowable (ASD) Diaphragm Shear Strength  $\frac{S_n}{\Omega}$  and Stiffness (G') for the given steel deck diaphragm.

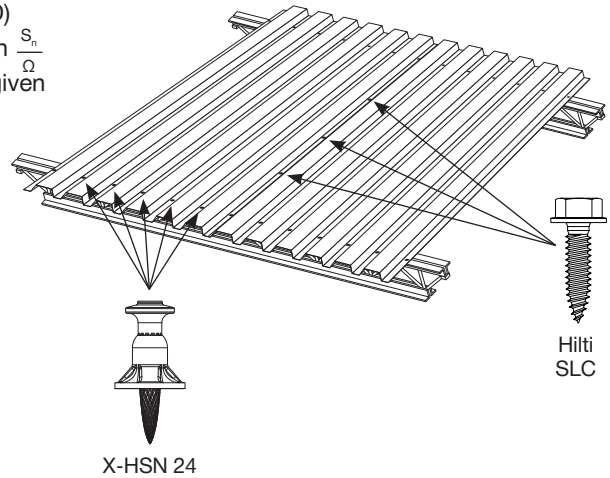

**Step 1:** Calculate nominal diaphragm shear strength limited by panel fasteners:

$$S_{ni} = \{2 \times A \times (\lambda - 1) + \beta\} \times \frac{P_{nf}}{L} = \{2 \times 1 \times (0.802 - 1) + 16.99\} \times \frac{2,107}{18} = 1,942 \text{ plf} \quad \text{AISI S310 Eq. D1-1}$$

Where:

$$A = 1 \quad \text{Technical Guide Table 7}$$

$$\lambda = 1 - \frac{D_d \times L_v}{240 \times \sqrt{t}} = 1 - \frac{1.5 \times 6}{240 \times \sqrt{0.0358}} = 0.802 \geq 0.7 \quad \text{AISI S310 Eq. D1-4a}$$

$$\beta = n_s \times \alpha_s + 2n_p \alpha_p^2 + 4\alpha_e^2 \quad \text{AISI S310 Eq. D1-5}$$

$$\alpha_p^2 = \left(\frac{1}{w^2}\right) \sum x_p^2 \quad \text{AISI S310 Eq. D1-7}$$

$$\alpha_e^2 = \left(\frac{1}{w^2}\right) \sum x_e^2 \quad \text{AISI S310 Eq. D1-8}$$

$$n_p = 2$$

$$\beta = n_s \times \alpha_s + 2n_p \alpha_p^2 + 4\alpha_e^2 = \frac{1}{w^2} \times [2 \times 2.0 \times S(x_p^2) + 4 S(x_e^2)] =$$

$$18 \times 0.598 + \frac{[2 \times 2 \times 1,008 + 4 \times 1,008]}{36^2} = 16.99$$

$$\sum(x_p^2) = \sum(x_e^2) = 1,008 \quad \text{Technical Guide Table 7}$$

$$\alpha_s = \frac{P_{ns}}{P_{nf}} = \frac{1,260}{2,107} = 0.598 \quad \text{AISI S310 Eq. D1-5}$$

**Step 2:** Calculate nominal diaphragm shear strength limited by corner fasteners:

$$S_{nc} = P_{nf} \times \sqrt{\frac{N^2 \times \beta^2}{L^2 \times N^2 + \beta^2}} = 2,107 \times \sqrt{\frac{2.00^2 \times 16.99^2}{18^2 \times 2.00^2 + 16.99^2}} = 1,798 \text{ plf} \quad \text{AISI S310 Eq. D1-2}$$

Where:

$$N = 2.00 \quad \text{Technical Guide Table 7}$$

$\beta$  = same as in step 1

**Step 3:** Calculate nominal diaphragm shear strength limited by edge fasteners:

$$S_{ne} = \frac{\{2\alpha_1 + n_p \times \alpha_2\} P_{nf} + n_e P_{nfs}}{L} = \frac{\{2 \times 2 + 2 \times 2\} \times 2,107 + 18 \times 2,107}{18} = 3,043 \text{ plf}$$

AISI S310 Eq. D1-3

Where:

$$\alpha_1 = \alpha_2 = 2$$

$$P_{nf} = P_{nfs}$$

$$n_e = \frac{L \times 12}{SS} = \frac{18 \times 12}{12} = 18$$

Technical Guide Table 7

**Step 4:** Calculate nominal diaphragm shear strength controlled by connections and adjusted by the correlation factor:  $S_{nf} = \min(S_{ni}, S_{nc}, \text{ and } S_{ne}) \quad c = 1,798 \times 1.127 = 2,026 \text{ plf}$

Where:

$$c = 1.127$$

Technical Guide Table 8

**Step 5:** Calculation allowable diaphragm shear strength controlled:

$$\frac{S_{nf}}{\Omega_{nf}} = \frac{2,026}{2.30} = 881 \text{ plf}$$

Where:

$$\Omega_{nf} = 2.30$$

Technical Guide Table 11

**Step 6:** Select allowable diaphragm buckling strength:

$$\frac{S_{nb}}{\Omega_{nb}} = 2,591 \text{ plf}$$

Technical Guide Table 12

**Step 7:** Determine allowable diaphragm shear strength:

$$\frac{S_{nf}}{\Omega} = \left( \frac{S_{nf}}{\Omega_{nf}}, \frac{S_{nb}}{\Omega_{nb}} \right) = 881 \text{ plf}$$

AISI S310 Eq. D-1

**Step 8:** Determine diaphragm stiffness:

$$G' = \left( \frac{Et}{2(1+\mu) \frac{s}{d} + Y_c D_n + C} \right) K, \text{ kips / in.}$$

AISI S310 Eq. D5.1.1-1

$$G' = \left( \frac{Et}{2(1+\mu) \frac{s}{d} + Y_c D_n + C} \right) K = \left( \frac{Et}{3.78 + 0.9D + C} \right) = \frac{29,500 \times 0.0358}{3.78 + 0.9D_n + C} = 93.61 \text{ kips/in.}$$

AISI S310 Eq. D1-5

$$F = \frac{1,000}{G'} = \frac{1,000}{93.61} = 10.68 \text{ micro-inches/lb}$$

AISI S310 Eq. D1-7

Where:

$$D_n = \frac{D}{L} = \frac{924}{18 \times 12} = 4.28$$

AISI S310 Eq. D1-8

$$D = 1,164 \text{ in.}$$

Technical Guide Table 7

$$C = \left( \frac{Et}{w} \right) \left( \frac{2L}{2\alpha_3 + n_p \alpha_4 + 2n_s \frac{S_f}{S_s}} \right) \quad S_f = \left( \frac{29,500 \times 0.0358}{36} \right) = \left( \frac{2 \times 18 \times 12}{2 \times 2 + 2 \times 2 + 2 \times 18 \times \frac{0.0066}{0.0159}} \right) 0.0066 = 5.65$$

AISI S310 Eq. D5.1.1-2

Where:

$$n_s = 18, \text{ same as Step 3}$$

$$n_p = 2$$

$$\alpha_3 = \alpha_4 = 2$$

Technical Guide Table 7

$$S_f = 0.0066$$

Technical Guide Table 9

$$S_s = 0.0159$$

Technical Guide Table 9

**NOTE:** Straight-line interpolation between different steel deck thicknesses and steel deck strengths for the calculation of diaphragm shear strength values is permitted. For example, to calculate the allowable diaphragm shear strength,  $\frac{S_n}{\Omega}$ , for 65 ksi steel deck, the following formula would be used.

$$\frac{S_n}{\Omega} (80 \text{ ksi}) = \frac{S_n}{\Omega} (65 \text{ ksi}) + (80 \text{ ksi} - 65 \text{ ksi}) \times \frac{\frac{S_n}{\Omega} (92 \text{ ksi}) - \frac{S_n}{\Omega} (65 \text{ ksi})}{92 - 65}$$

Where:

$$\frac{S_n}{\Omega} (65 \text{ ksi}) = \text{Allowable diaphragm shear for 45 ksi steel deck.}$$

$$\frac{S_n}{\Omega} (92 \text{ ksi}) = \text{Allowable diaphragm shear for 92 ksi steel deck.}$$

$$\frac{S_n}{\Omega} (80 \text{ ksi}) = \text{Allowable diaphragm shear for 65 ksi steel deck.}$$

Similarly, to calculate the allowable diaphragm shear,  $S_{ASD}$ , for 19 gauge (0.0418 in.) steel deck, the following formula would be used.

$$\frac{S_n}{\Omega} (19 \text{ Ga.}) = \frac{S_n}{\Omega} (20 \text{ Ga.}) + (0.0418 \text{ in.} - 0.0358 \text{ in.}) \times \frac{\frac{S_n}{\Omega} (18 \text{ ga.}) - \frac{S_n}{\Omega} (20 \text{ ga.})}{0.0474 \text{ in.} - 0.0358 \text{ in.}}$$

Where:

$$\frac{S_n}{\Omega} (20 \text{ Ga.}) = \text{Allowable diaphragm shear for 20 gauge (0.0358 in.) steel deck.}$$

$$\frac{S_n}{\Omega} (18 \text{ Ga.}) = \text{Allowable diaphragm shear for 18 gauge (0.0474 in.) steel deck.}$$

$$\frac{S_n}{\Omega} (19 \text{ Ga.}) = \text{Allowable diaphragm shear for 19 gauge (0.0418 in.) steel deck.}$$

Hilti is a leading manufacturer of direct fastening systems for steel and metal applications. As an associate member of the Steel Deck Institute (SDI), Hilti participates in and supports steel deck industry research at leading universities and test labs. Recent research projects with Hilti direct fastening systems have included inelastic seismic deck diaphragms and deep deck / cellular deck diaphragms.

Independent tests are the best guide to product performance and reliability, a philosophy to which Hilti and the SDI subscribe. The support for ongoing research programs is indicated by the number and scope of tests already performed and by the policy of sponsoring new tests when new products or applications are introduced. Hilti provides direct fastening system performance data, ICC-ES Evaluation Service Reports, design software, fire ratings and load test results for Hilti direct fastening systems used in steel deck applications.

Diaphragm data is calculated in accordance with AISI and SDI Diaphragm Design equations using specific Hilti fastener strength and stiffness values with data correlation adjustment factors in accordance with ICC-ES AC43 requirements.





### 3.5.1.8 HOW TO USE DIAPHRAGM SHEAR TABLES

**General:** The following Product Technical Guide Sections 3.5.2 to 3.5.5 provide Hilti fastener product technical data sheets and pre-calculated diaphragm shear and stiffness tables using the design equations provided in Section 3.5.1.7. Pre-calculated diaphragm shear and stiffness tables are provided in two formats.

Tables in Sections 3.5.2, 3.5.3, 3.5.4 and 3.5.5 are in a traditional design format with diaphragm shear and stiffness values within the table.

These tables do not take into account other design factors, such as gravity or wind uplift loads. These requirements should be checked separately by the Structural Engineer.

**Traditional diaphragm shear tables:** Sections 3.5.2, 3.5.3, 3.5.4 and 3.5.5 provide tables in a format similar to those published in the SDI DDM04, CSSBI and most steel deck manufacturers' catalogs.

As shown in Figure 18, these diaphragm shear tables are generally created with span across the heading and number of sidelap screws along the left margin or column. Along with other design variables such as deck gauge and fastener pattern, the tables are populated with the corresponding diaphragm shear and stiffness values.

#### Example table

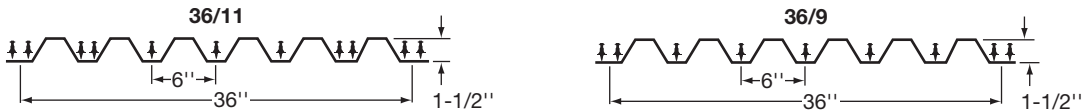

**Figure 18 — Allowable Stress Design (ASD) – Allowable diaphragm shears,  $S_{ASD}$ , (plf) and stiffness factors,  $G'$ , (kips/in.) for standard 1-1/2" deep flutes, 6" center-to-center deck ( $F_y \geq 50$ ksi;  $F_u \geq 65$  ksi) installed with Hilti X-HSN 24 fasteners with 36/11 or 36/9 end and interior support fastener patterns <sup>1,2,3,4,5</sup>**

Gauge	Number of Hilti SLC per span	Factor	Span (ft - in.)														
			4'-0"		5'-0"		6'-0"		7'-0"		8'-0"		9'-0"		10'-0"		
			11	9	11	9	11	9	11	9	11	9	11	9	11	9	
22	2	$S_{ASD}$	1065	920	876	762	726	636	616	539	534	466	473	413	426	372	
		$G'$	62.8	61.0	67.2	64.7	69.2	66.0	69.7	66.0	69.2	65.0	68.0	63.5	66.5	61.7	
	3	$S_{ASD}$	1158	1006	957	840	807	717	685	608	594	527	527	467	474	420	
		$G'$	64.2	62.7	69.1	67.0	71.7	69.1	72.7	69.5	72.6	69.0	71.7	67.8	70.4	66.2	
	4	$S_{ASD}$	1246	1087	1036	913	883	783	755	677	655	587	581	521	523	469	
		$G'$	65.3	64.1	70.8	69.0	73.9	71.6	75.3	72.5	75.5	72.4	74.9	71.5	73.8	70.1	
	5	$S_{ASD}$	1329	1161	1111	983	950	847	824	742	715	648	635	575	571	517	
		$G'$	66.2	65.2	72.2	70.7	75.7	73.7	77.5	75.1	78.1	75.3	77.8	74.7	76.9	73.6	
	6	$S_{ASD}$	1408	1230	1184	1049	1016	908	887	798	776	708	689	628	620	566	
		$G'$	67.0	66.2	73.4	72.1	77.3	75.6	79.4	77.3	80.3	77.9	80.3	77.6	79.7	76.7	
	7	$S_{ASD}$	1482	1293	1253	1111	1080	967	945	852	837	760	743	682	668	614	
		$G'$	67.7	67.0	74.4	73.3	78.7	77.2	81.2	79.3	82.4	80.2	82.6	80.2	82.2	79.5	
	20	2	$S_{ASD}$	1415	1225	1166	1017	976	859	829	729	719	631	633	555	569	499
			$G'$	86.8	83.8	90.1	86.0	90.6	85.7	89.4	83.8	87.2	81.2	84.5	78.2	81.5	75.1
3		$S_{ASD}$	1549	1349	1283	1128	1091	965	930	830	808	720	712	634	640	570	
		$G'$	89.2	86.7	93.3	89.9	94.5	90.3	93.8	89.0	92.0	86.8	89.6	84.1	86.9	81.1	
4		$S_{ASD}$	1675	1462	1396	1233	1192	1060	1032	927	896	808	791	713	711	641	
		$G'$	91.1	89.0	96.0	93.1	97.8	94.2	97.7	93.5	96.3	91.7	94.2	89.3	91.7	86.5	
5		$S_{ASD}$	1793	1566	1505	1332	1289	1151	1125	1010	985	897	870	792	782	712	
		$G'$	92.8	91.0	98.3	95.8	100.7	97.6	101.1	97.4	100.1	96.0	98.3	93.9	96.0	91.4	
6		$S_{ASD}$	1904	1662	1608	1425	1384	1238	1210	1091	1074	972	949	871	853	783	
		$G'$	94.2	92.7	100.4	98.2	103.3	100.5	104.1	100.9	103.5	99.9	102.0	98.0	99.9	95.7	
7		$S_{ASD}$	2007	1748	1706	1511	1475	1321	1294	1168	1150	1044	1028	942	924	854	
		$G'$	95.5	94.1	102.1	100.2	105.6	102.1	106.8	103.0	106.6	102.2	105.4	101.8	103.5	98.7	