



Classified by  
Underwriters Laboratories, Inc.  
to UL 2079 and CAN/ULC-S115

# System No. WW-D-0270

WW-D-0270

ANSI/UL2079	CAN/ULC S115
Assembly Rating — 2 Hr	F Rating — 2 Hr
Nominal Joint Width - 2 in.	FT Rating — 2 Hr
Class II Movement Capabilities — 12.5% Compression or Extension	FH Rating — 2 Hr
L Rating at Ambient — Less than 1 CFM/Lin Ft	FTH Rating — 2 Hr
L Rating at 400°F — Less than 1 CFM/Lin Ft	Nominal Joint Width – 51 mm
	Class II Movement Capabilities — 12.5% Compression or Extension
	L Rating at Ambient — Less than 5.1 L/s/m2
	L Rating at 400°F — Less than 5.1 L/s/m2

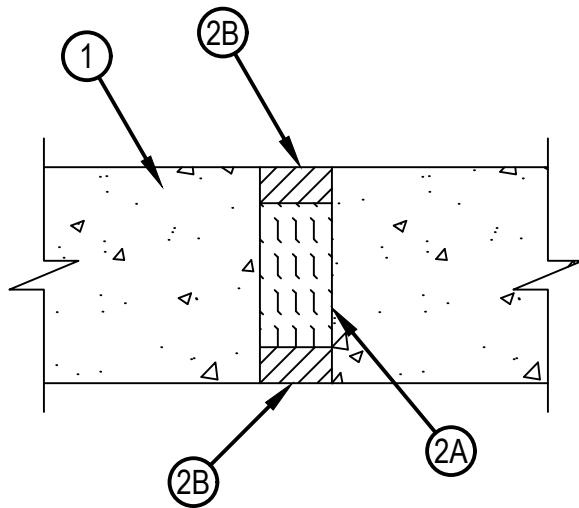

**CONFIGURATION A**

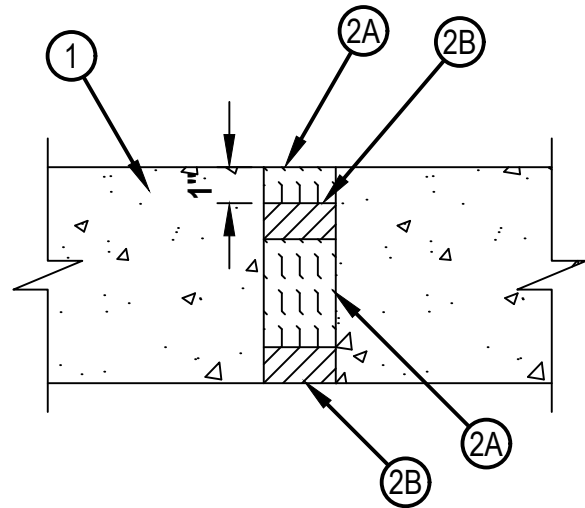

**CONFIGURATION B**



**Hilti Firestop Systems**

Reproduced by HILTI, Inc. Courtesy of  
Underwriters Laboratories, Inc.  
May 05, 2021

# System No. WW-D-0270

WW-D-0270

1. Wall Assembly — Min 4-1/2 in. (114 mm) thick reinforced lightweight or normal weight (100-150 pcf or 1600-2400 kg/m<sup>3</sup>) structural concrete. Wall may also be constructed of any UL Classified Concrete Blocks\*.

See Concrete Block (CAZT) category in the Fire Resistance Directory for names of manufacturers.

2. Joint System —Max width of joint (at time of installation of joint system) is 2 in. (51 mm). The joint system is designed to accommodate a max 12.5 percent compression or extension from its installed width. The joint system shall consist of the following:

A. Forming Material\* —Min 4 pcf (64 kg/m<sup>3</sup>) mineral wool batt insulation installed in joint opening as a permanent form. Pieces of batt cut to a min width as specified in Table below and installed edge-first into joint opening, parallel with joint direction, such that batt sections are compressed min 50 percent in thickness and such that the compressed batt sections are recessed from the both surfaces of the wall as required to accommodate the required thickness of fill material (Configuration A). Adjoining lengths of batt to be tightly-butted with butted seams spaced min 24 in. (610 mm) apart along the length of the joint. In walls with one side access as shown in Configuration B, min 1 in. (25 mm) width of Forming Material shall first be installed within joint as described above approximately flush with inaccessible side of wall, followed by the Sealant (Item 2B) and Forming Material (Item 2A) as specified in the Table below.

INDUSTRIAL INSULATION GROUP L L C — MinWool-1200 Safing

JOHNS MANVILLE — Safing

ROCKWOOL MALAYSIA SDN BHD — SAFE

ROCKWOOL — SAFE

THERMAFIBER INC — SAF

B. Fill, Void or Cavity Material\* — Sealant —Min thickness of fill material as specified in Table below to be applied within the joint, flush with both surfaces of wall (Configuration A). In walls with one side access as shown in Configuration B, sealant to be applied within the joint over the min 1 in. (25 mm) of Forming Material described in Item 2A, and additional sealant then installed within joint flush with accessible side of wall after the remaining Forming Material (Item 2A) is installed within joint, as specified in the Table below.

HILTI CONSTRUCTION CHEMICALS, DIV OF HILTI INC — CP606 Flexible Firestop Sealant

Joint System Hourly Rating	Max Joint Width In. (mm)	Min Width of Forming Material (Item 2A) In. (mm)	Min Thickness of Sealant (Item 2B) In. (mm)
2	2 (51)	2 (51)	1/2 (13)
2	1 (25)	2.5 (64)	1/4 (6)

\* Indicates such products shall bear the UL or cUL Certification Mark for jurisdictions employing the UL or cUL Certification (such as Canada), respectively.



Hilti Firestop Systems

Reproduced by HILTI, Inc. Courtesy of  
Underwriters Laboratories, Inc.  
May 05, 2021