



Classified by  
Underwriters Laboratories, Inc.  
to UL 2079 and CAN/ULC-S115

## System No. HW-D-0929

HWD 0929

ANSI/UL2079	CAN/ULC S115
Assembly Rating — 3 Hr	F Rating — 3 Hr
Nominal Joint Width - 1 in.	FT Rating — 3 Hr
Class II and III Movement Capabilities — 25% Compression or Extension	FH Rating — 3 Hr
	FTH Rating — 3 Hr
	Nominal Joint Width – 25 mm
	Class II and III Movement Capabilities — 25% Compression or Extension

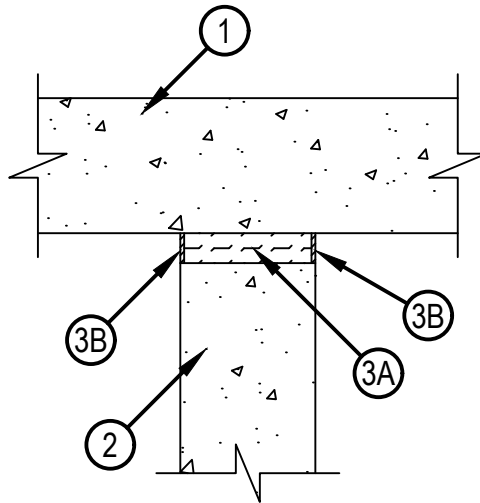

1. Floor Assembly — Min 4-1/2 in (114 mm). thick steel-reinforced lightweight or normal weight (100-150 pcf or 1600-2400 kg/m<sup>3</sup>) structural concrete.
2. Wall Assembly — Min 4-1/2 in (114 mm). thick steel-reinforced lightweight or normal weight (100-150 pcf or 1600-2400 kg/m<sup>3</sup>) structural concrete. Wall may also be constructed of any UL Classified Concrete Blocks\*.
3. Joint System — Max width of joint (at time of installation of joint system) is 1 in. (25 mm). The joint system is designed to accommodate a max 25 percent compression or extension from its installed width. The joint system shall consist of the following:
  - A. Forming Material\* — Min 4 pcf (64 kg/m<sup>3</sup>) mineral wool batt insulation installed in joint opening as a permanent form. Batt cut to min width of 4 in. (102 mm) and installed cut edge-first into joint opening, parallel with joint direction, such that batt sections are compressed min 50 percent in thickness and such that the compressed batt sections are recessed from both surfaces of wall to accommodate the required thickness of fill material. Adjoining lengths of batt to be tightly butted.  
INDUSTRIAL INSULATION GROUP L L C — MinWool-1200 Safing  
JOHNS MANVILLE – Safing  
ROCKWOOL MALAYSIA SDN BHD — SAFE  
ROCKWOOL — SAFE  
THERMAFIBER INC — SAF
  - B. Fill, Void or Cavity Material\* — 1/16 in. (1.6 mm) dry thickness (min 1/8 in. or 3.2 mm wet thickness) of fill material applied within the joint, flush with both surfaces of wall.  
HILTI CONSTRUCTION CHEMICALS, DIV OF HILTI INC — CFS-SP WB Firestop Joint Spray

\* Indicates such products shall bear the UL or cUL Certification Mark for jurisdictions employing the UL or cUL Certification (such as Canada), respectively.



Reproduced by HILTI, Inc. Courtesy of  
Underwriters Laboratories, Inc.  
April 22, 2021