



Classified by
Underwriters Laboratories, Inc.
to UL 1479 and CAN/ULC-S115

System No. W-L-3484

WL 3484

ANSI/UL1479 (ASTM E814)	CAN/ULC S115
F Ratings – 1 and 2 Hr	F Ratings – 1 and 2 Hr
T Ratings – 0, 1 Hr	FT Ratings - 0, 1 Hr
L Rating at Ambient – Less than 1 to 3 CFM/Device (See Item 3)	FH Ratings – 1 and 2 Hr
L Rating at 400 F - Less than 1 to 1.6 CFM/Device (See Item 3)	FTH Ratings - 0, 1 Hr
	L Rating at Ambient – Less than 0.47 to 1.41 L/s/Device (see Item 3)
	L Rating at 400 F – Less than 0.47 to 0.76 L/s/Device (see Item 3)

FRONT VIEW

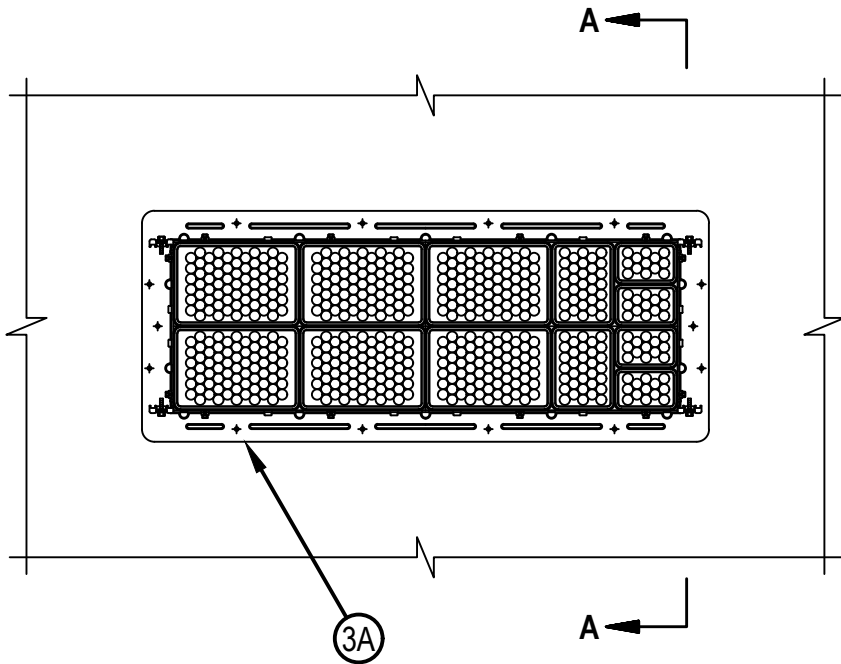

SECTION A-A

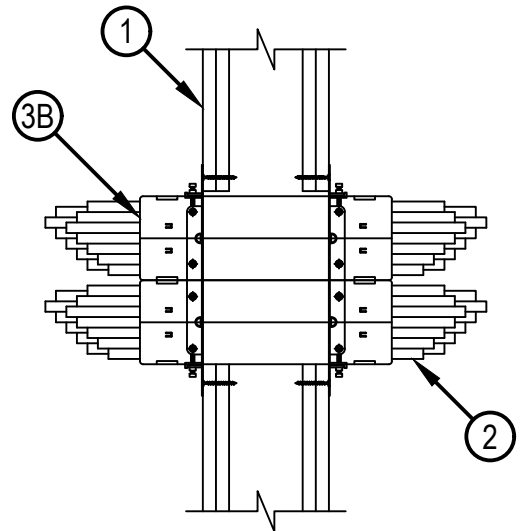

Reproduced by HILTI, Inc. Courtesy of
Underwriters Laboratories, Inc.
February 08, 2024

1. Wall Assembly — The 1 or 2 hr fire rated gypsum board/stud wall assembly shall be constructed of the materials and in the manner described within the individual U300, U400, V400 or W400 Series Wall and Partition Designs in the UL Fire Resistance Directory and shall incorporate the following construction features:
 - A. Studs — Wall framing shall consist of either wood studs or steel channel studs. Wood studs to consist of nom 2 by 4 in. (51 by 102 mm) lumber spaced max 16 in. (406 mm) OC. Steel studs to be min 3-5/8 in. (92 mm) wide and spaced max 24 in. (610 mm) OC for 1 and 2 hr wall assemblies.
 - B. Gypsum Board* — Nom 5/8 in. (16 mm) thick gypsum board as specified in the individual Wall and Partition Design. Alternately, for 1 and 2 hr rated walls only, min one layer of nom 3/4 in. (19 mm) thick gypsum board on each side of wall as specified in the individual Wall and Partition Design may be used. Opening in gypsum board to be max 24-1/8 in. (612.8 mm) x 8-1/8 in. (206.4 mm). When opening width exceeds the width of stud cavity, additional framing members shall be used to completely frame around the opening.

The hourly F and FH Ratings of the firestop system are dependent upon the hourly rating of the wall in which it is installed.
2. Cables — Within the loading area for each firestop device, the cables may represent a 0 to 100 percent visual fill. Cables to be rigidly supported on both sides of wall assembly. Any combination of the following types of cables may be used:
 - A. Max 100 pair No. 24 AWG (or smaller) copper conductor telecommunication cable with polyvinyl chloride (PVC) jacketing and insulation.
 - B. Max 7/C No. 12 AWG copper conductor control cable with PVC or XLPE jacket and insulation.
 - C. Max 4/0 AWG Type RHH ground cable.
 - D. Max 4 pr No. 23 AWG Cat 7 computer cables.
 - E. Max RG 6/U coaxial cable with fluorinated ethylene insulation and jacketing.
 - F. Fiber optic cable with polyvinyl chloride (PVC) or polyethylene (PE) jacket and insulation having a max diam of 1/2 in. (13 mm).
 - G. Max 20/C No. 22 AWG shielded printer cable with PVC jacket.
 - H. Max. 1/4 in. (6 mm) diameter S-Video Cable consisting of 2 max 24 AWG 75 ohm coax or twisted pair cable with PE insulation and PVC jacket .
 - I. Through-Penetrating Product* - Two copper conductors No. 18 AWG (or smaller) Power or Non Power Limited Fire Alarm Cable with or without a jacket under a metal armor.

AFC CABLE SYSTEMS INC

 - J. Max 3/C No 12 AWG MC Cable.
 - K. Through Penetrating Product* — Any cables, Armored Cable+ or Metal Clad Cable+ currently Classified under the Through Penetrating Product category. See Through Penetrating Product (XHLY) category in the Fire Resistance Directory for names of manufacturers. When the hourly rating of the wall assembly is 1 hr, the T, FT, and FTH Ratings are 0 hr. When the hourly rating of the wall assembly of the wall assembly is 2 hr, the T, FT, and FTH ratings are 1 hr.
3. Firestop System – The firestop system shall consist of the following:
 - A. Device Flange – Rectangular adjustable flange sized to fit around ganged sleeves, bolted together and secured to both sides of the wall (Item 1) by means of 1-1/2 in. (38 mm) long steel screws along top and bottom of horizontal frame members at minimum every other hole. Corners of horizontal frame secured with 2 in. long steel screws into studs (Item 1A). Prior to securing flange to wall, gasket to be cut to length of each flange section and applied to back side of flange with integrated tape.
HILTI CONSTRUCTION CHEMICALS, DIV OF HILTI INC — CFS-MSL GPA 24 x 4", CFS-MSL GPA 24 x 8" Adjustable Gangplate
 - B. Firestop Device* — Firestop devices each consist of a rectangular outer steel sleeve formed with two half housings, connected and secured together. Multiple Firestop devices connected together with ganging clips and installed in accordance with the accompanying installation instructions in single or double row. Devices slid into wall such that ends project an equal distance from the approximate centerline of the wall assembly. The annular space between the device and the periphery of the opening shall be min 0 in. (point contact) to maximum 1/8 in (3 mm). Devices are installed adjacent to one another with gaskets and flanges (Item 3A) installed on both sides of wall. Devices secured to flange with accompanying screws at minimum every other hole in flange.

The L Ratings are dependent on the type and number of devices within the gang plate and the cable type and fill. The L Ratings are expressed in CFM per device. A rating of less than one shall be considered as 1 CFM when more than one module is installed.



System No. W-L-3484

WL 3484

Device	Max Cable Fill	Cable Type	L-Rating (CFM)	
			Ambient	400°F
CFS-MSL S	0%	-	Less than 1	Less than 1
CFS-MSL S	1-25%	2B, 2D, 2E, 2G, 2H	1.1	1.5
CFS-MSL S	26-50%	2B, 2D, 2E, 2G, 2H	1.1	Less than 1
CFS-MSL S	51-75%	2B, 2D, 2E, 2G, 2H	1.8	Less than 1
CFS-MSL S	76-100%	2B, 2D, 2E, 2G, 2H	1.8	1.2
CFS-MSL M	0%	-	1.1	Less than 1
CFS-MSL M	1-25%	2B, 2D, 2E, 2G, 2H	1.8	Less than 1
CFS-MSL M	26-50%	2B, 2D, 2E, 2G, 2H	1.9	Less than 1
CFS-MSL M	51-75%	2B, 2D, 2E, 2G, 2H	1.9	Less than 1
CFS-MSL M	76-100%	2B, 2D, 2E, 2G, 2H	2.2	1.1
CFS-MSL L	0%	-	1.2	Less than 1
CFS-MSL L	1-25%	2B, 2D, 2E, 2G, 2H	1.8	1.1
CFS-MSL L	26-50%	2B, 2D, 2E, 2G, 2H	2.2	1.0
CFS-MSL L	51-75%	2B, 2D, 2E, 2G, 2H	2.6	1.4
CFS-MSL L	76-100%	2B, 2D, 2E, 2G, 2H	3.0	1.6

HILTI CONSTRUCTION CHEMICALS, DIV OF HILTI INC — CFS-MSL L 6" x 4", CFS-MSL M 3" x 4", CFS-MSL S 3" x 2" Modular Sleeve

* Indicates such products shall bear the UL or cUL Certification Mark for jurisdictions employing the UL or cUL Certification (such as Canada), respectively.

+Bearing the UL Listing Mark



Reproduced by HILTI, Inc. Courtesy of
Underwriters Laboratories, Inc.
February 08, 2024