

ITEM	DESCRIPTION	QUANTITY
1	CHANNEL PROFILE	1
2	RIVET CONNECTION	2
3	ROUNDED HEADED ANCHOR	2
4	END CAP	2
5	TEAR OUT BAND	1
6	FILLER FOAM	1

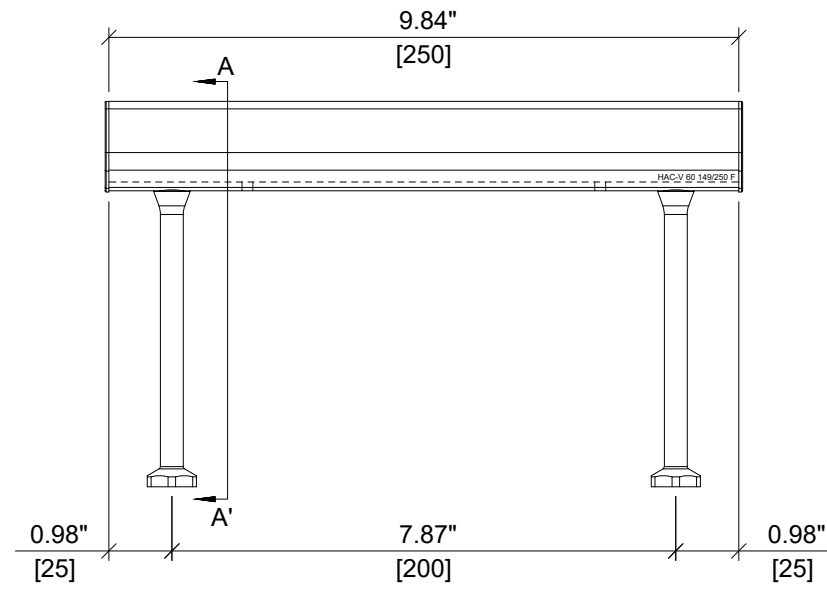

ELEVATION VIEW

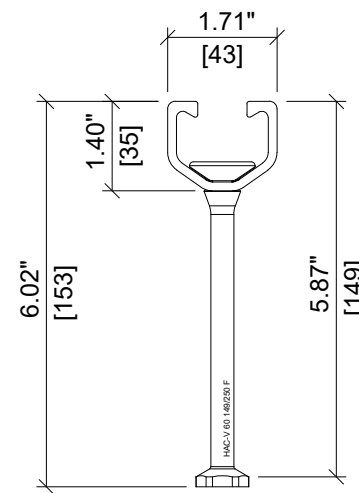

SECTION A-A'

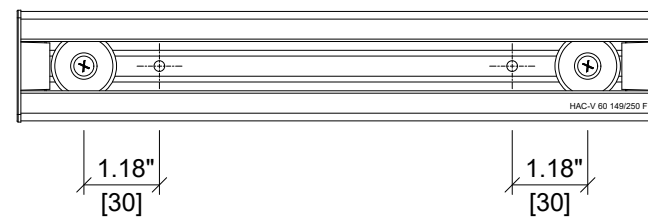

PLAN VIEW

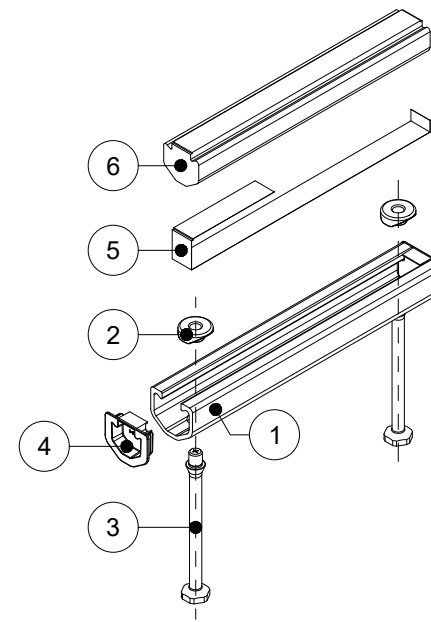

ISOMETRIC VIEW

HILTI

ITEM NUMBER: <div style="font-size: 18px; font-weight: bold; text-align: center;">2361270</div>	CHANNEL LIP: <div style="font-size: 18px; font-weight: bold; text-align: center;">SMOOTH</div>
ITEM DESCRIPTION: <div style="font-size: 18px; font-weight: bold; text-align: center;">HAC-V 60 149/250 F</div>	



ITEM	DESCRIPTION	QUANTITY
1	CHANNEL PROFILE	1
2	RIVET CONNECTION	2
3	ROUNDED HEADED ANCHOR	2
4	END CAP	2
5	TEAR OUT BAND	1
6	FILLER FOAM	1

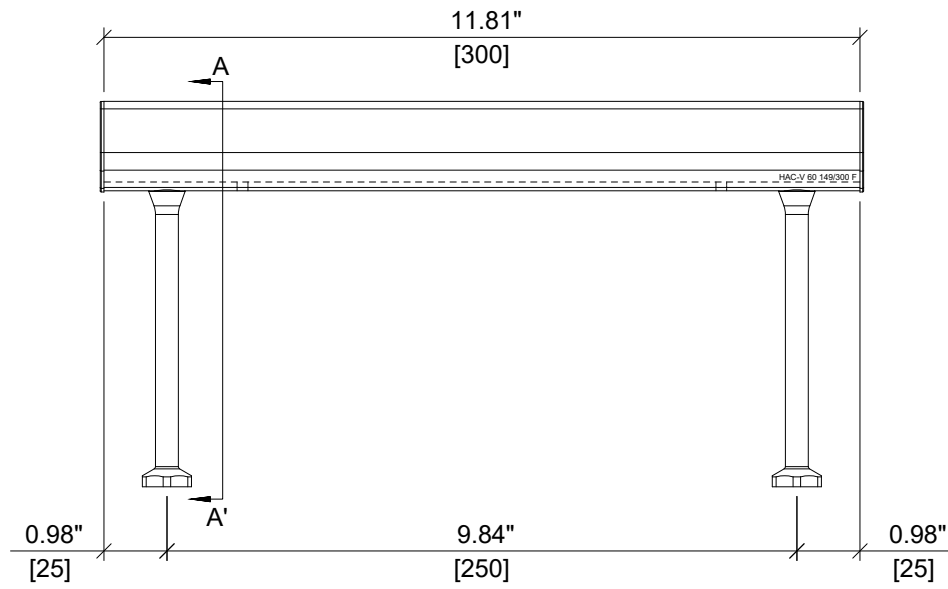

ELEVATION VIEW

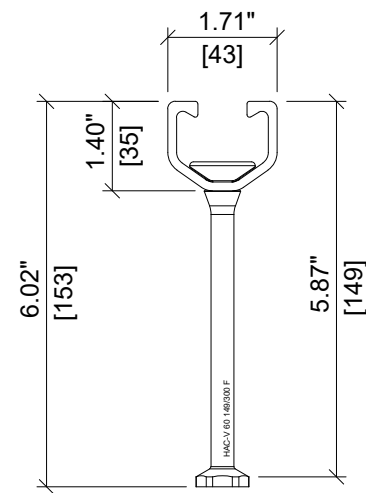

SECTION A-A'

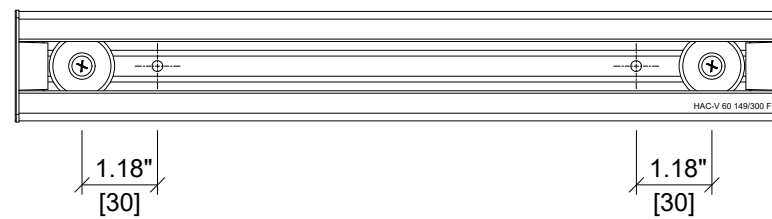

PLAN VIEW

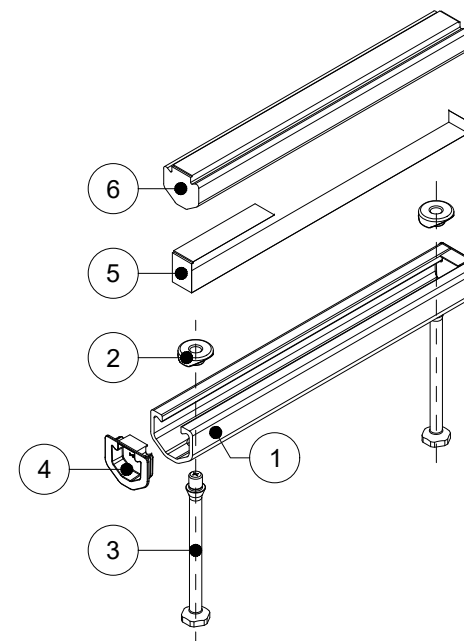

ISOMETRIC VIEW

HILTI

ITEM NUMBER: <div style="font-size: 18px; font-weight: bold; text-align: center;">2331576</div>	CHANNEL LIP: <div style="font-size: 18px; font-weight: bold; text-align: center;">SMOOTH</div> <div style="text-align: right; margin-top: 5px;"> </div>
ITEM DESCRIPTION: <div style="font-size: 18px; font-weight: bold; text-align: center;">HAC-V 60 149/300 F</div>	



ITEM	DESCRIPTION	QUANTITY
1	CHANNEL PROFILE	1
2	RIVET CONNECTION	3
3	ROUNDED HEADED ANCHOR	3
4	END CAP	2
5	TEAR OUT BAND	1
6	FILLER FOAM	1

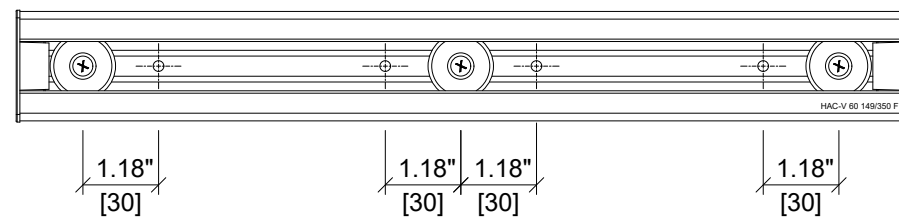
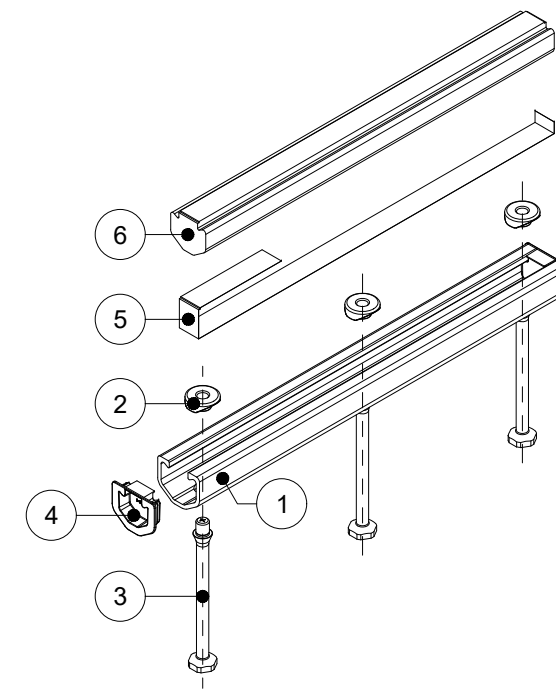
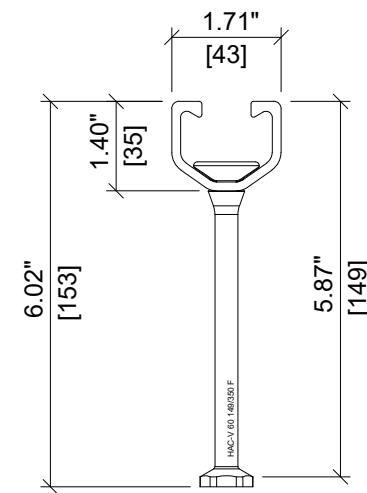
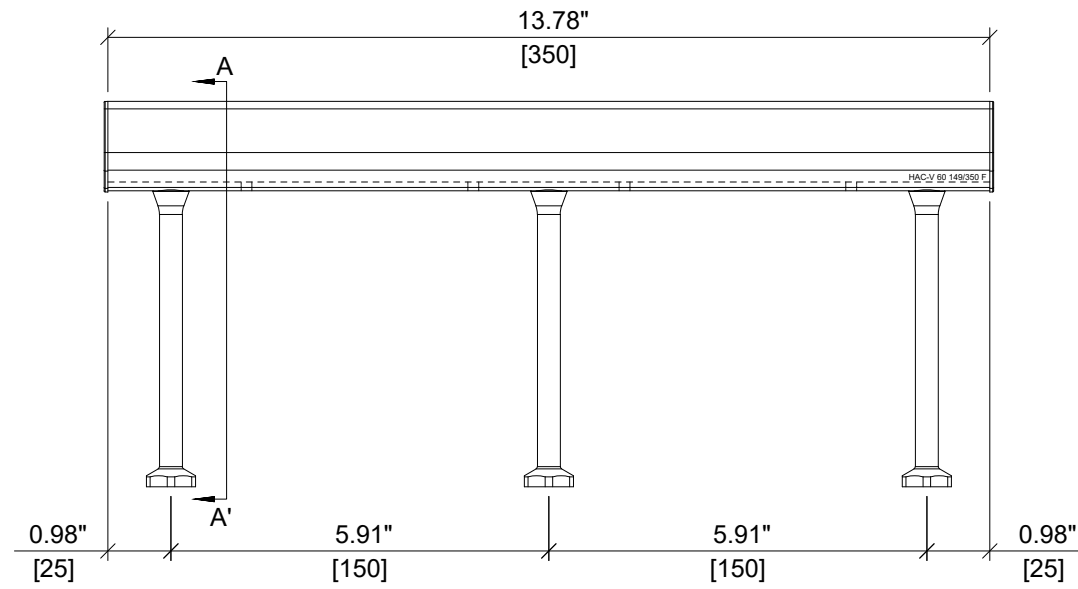

HILTI

ITEM NUMBER: 2331577

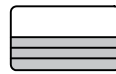
CHANNEL LIP: SMOOTH 

ITEM DESCRIPTION: HAC-V 60 149/350 F



ITEM	DESCRIPTION	QUANTITY
1	CHANNEL PROFILE	1
2	RIVET CONNECTION	3
3	ROUNDED HEADED ANCHOR	3
4	END CAP	2
5	TEAR OUT BAND	1
6	FILLER FOAM	1

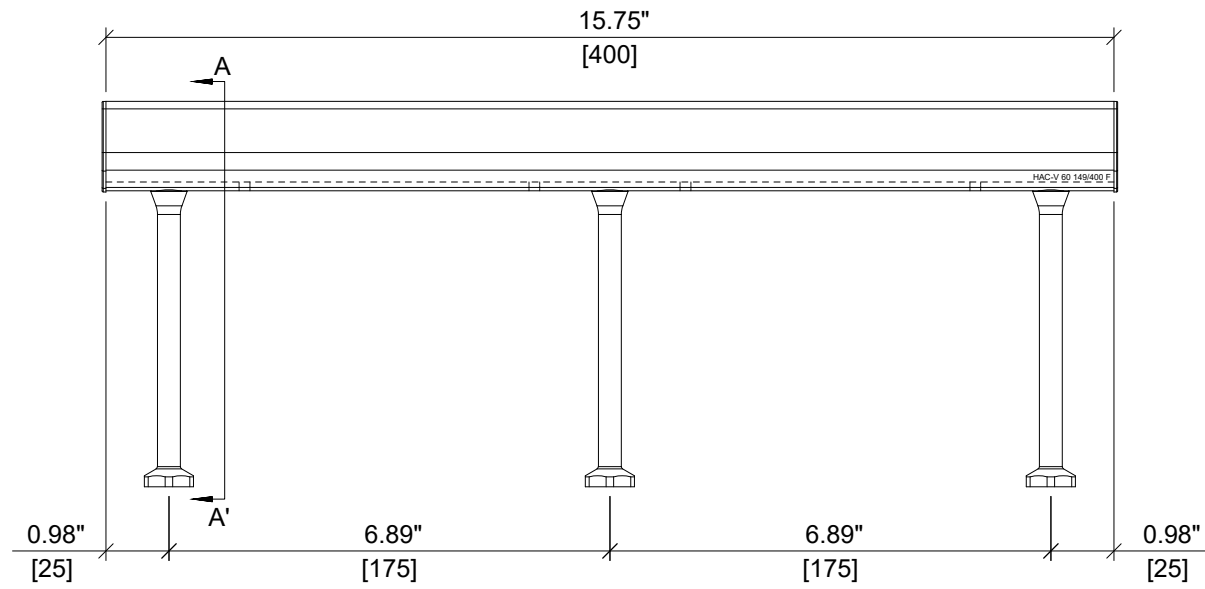

ELEVATION VIEW

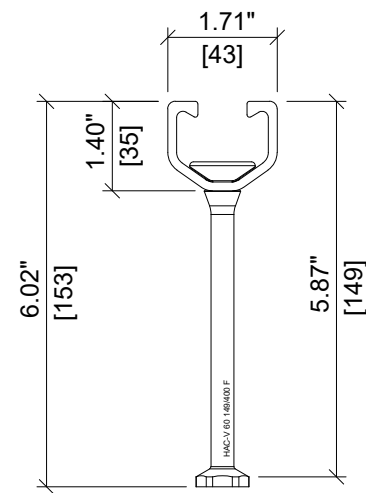

SECTION A-A'

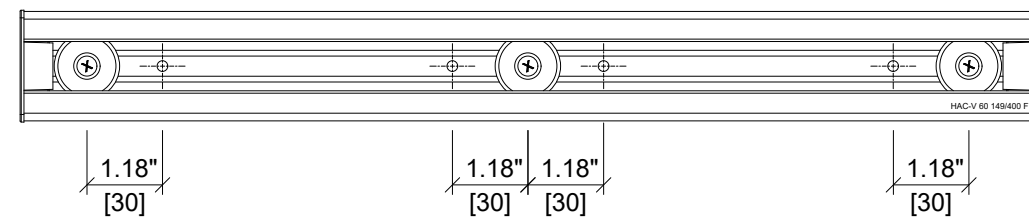

PLAN VIEW

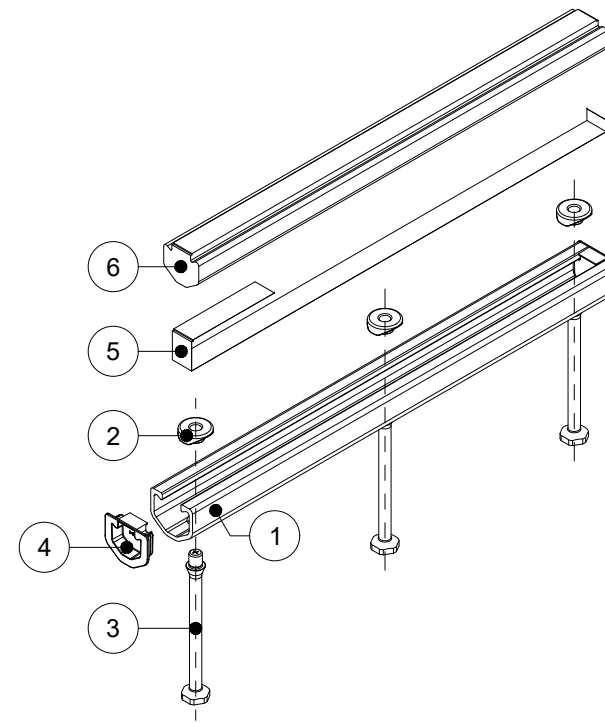

ISOMETRIC VIEW

HILTI

ITEM NUMBER: <div style="font-size: 18px; font-weight: bold; text-align: center;">2331578</div>	CHANNEL LIP: <div style="font-size: 18px; font-weight: bold; text-align: center;">SMOOTH</div> <div style="text-align: right; margin-top: 5px;"> </div>
ITEM DESCRIPTION: <div style="font-size: 18px; font-weight: bold; text-align: center;">HAC-V 60 149/400 F</div>	



ITEM	DESCRIPTION	QUANTITY
1	CHANNEL PROFILE	1
2	RIVET CONNECTION	3
3	ROUNDED HEADED ANCHOR	3
4	END CAP	2
5	TEAR OUT BAND	1
6	FILLER FOAM	1

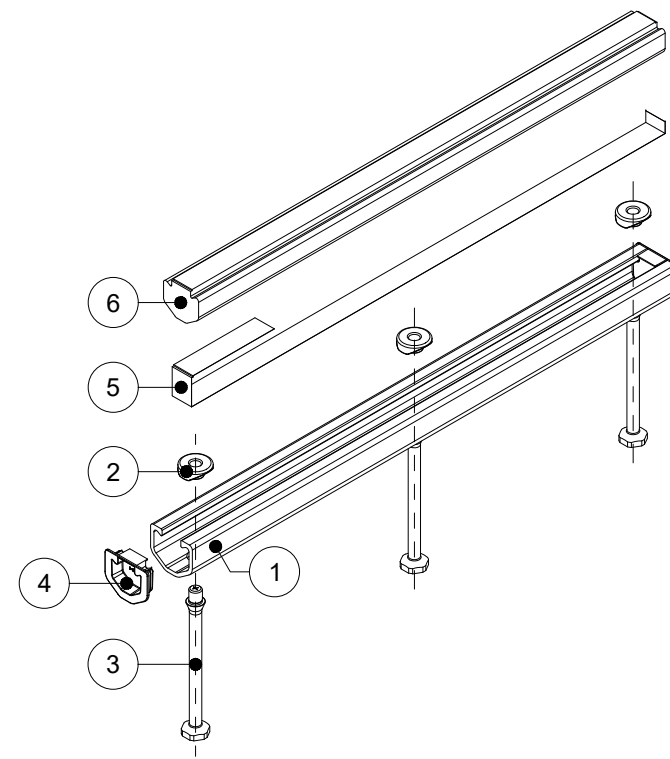
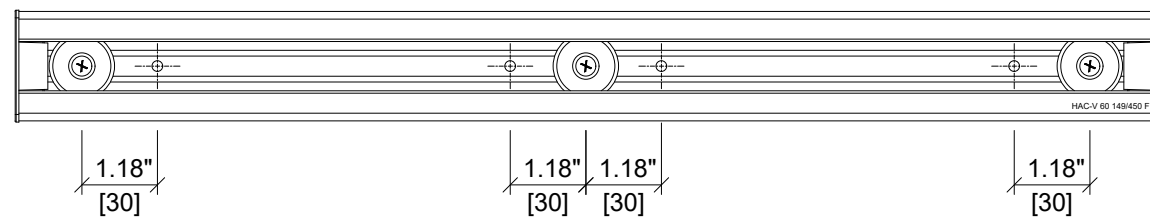
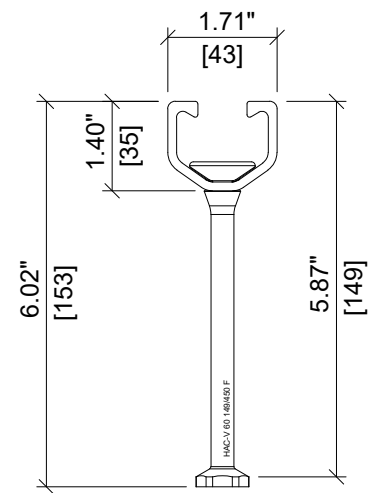
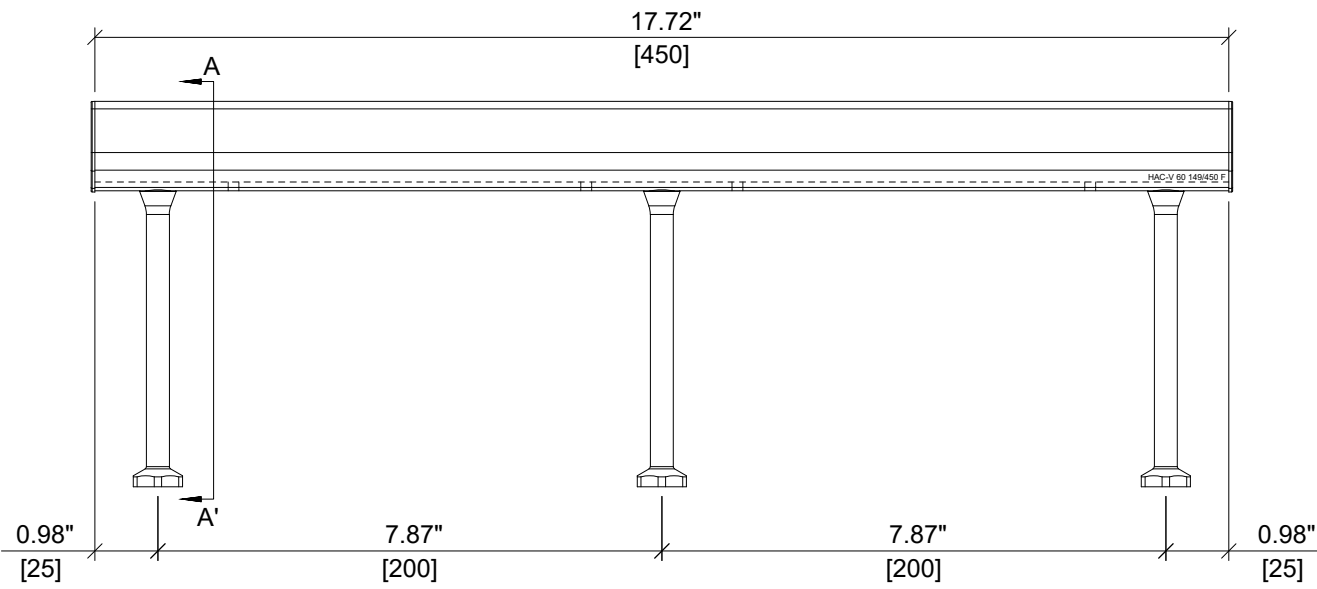

HILTI

ITEM NUMBER: <div style="font-size: 18px; font-weight: bold;">2331579</div>	CHANNEL LIP: <div style="font-size: 18px; font-weight: bold;">SMOOTH</div>
ITEM DESCRIPTION: <div style="font-size: 18px; font-weight: bold;">HAC-V 60 149/450 F</div>	



ITEM	DESCRIPTION	QUANTITY
1	CHANNEL PROFILE	1
2	RIVET CONNECTION	3
3	ROUNDED HEADED ANCHOR	3
4	END CAP	2
5	TEAR OUT BAND	1
6	FILLER FOAM	1

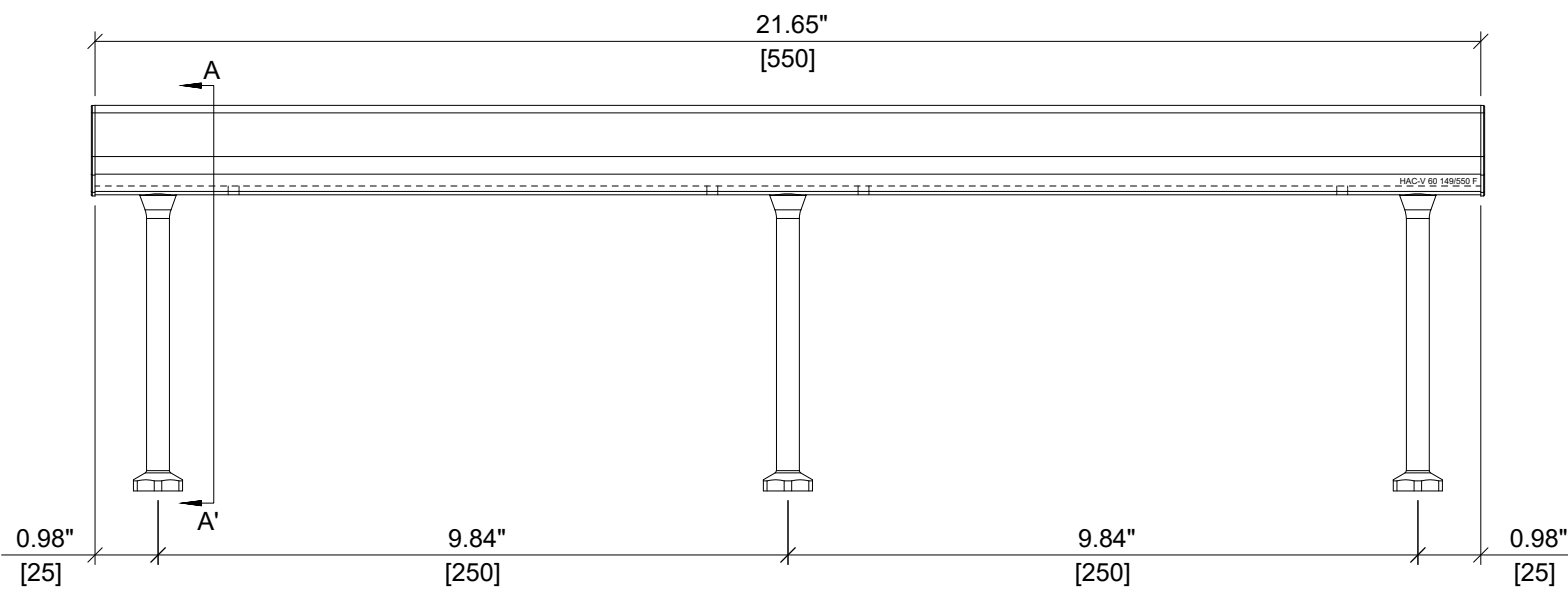

ELEVATION VIEW

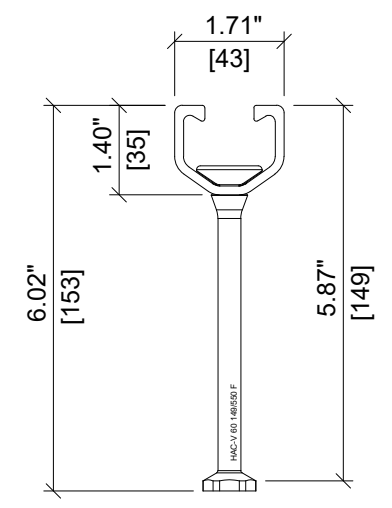

SECTION A-A'

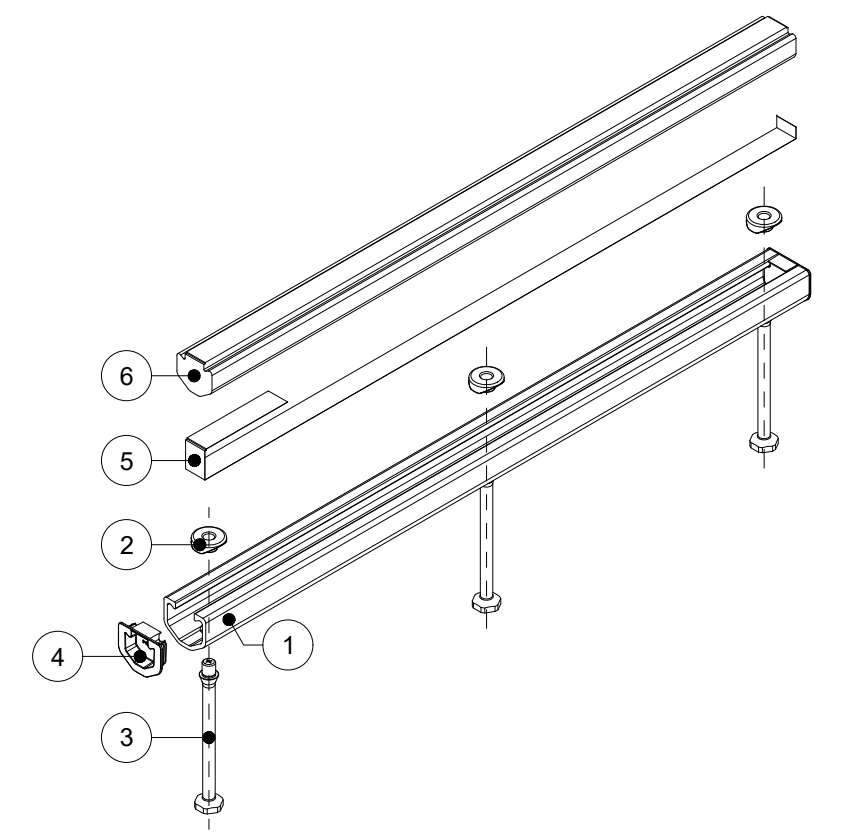

ISOMETRIC VIEW

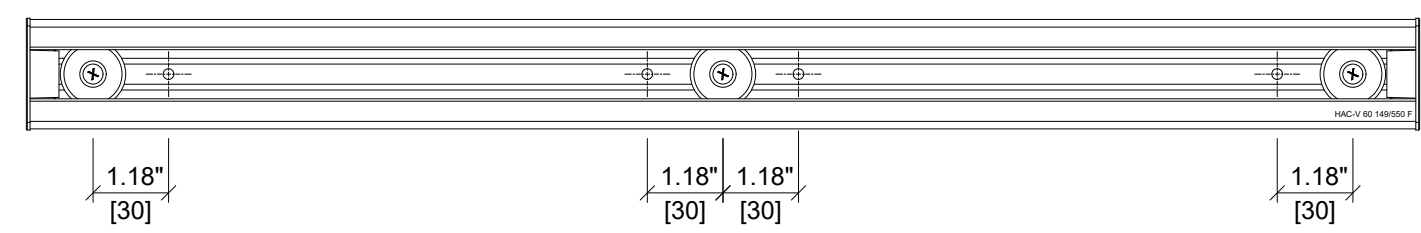

PLAN VIEW



ITEM NUMBER: 2331580	CHANNEL LIP: SMOOTH
--------------------------------	-------------------------------

ITEM DESCRIPTION:
HAC-V 60 149/550 F



ITEM	DESCRIPTION	QUANTITY
1	CHANNEL PROFILE	1
2	RIVET CONNECTION	4
3	ROUNDED HEADED ANCHOR	4
4	END CAP	2
5	TEAR OUT BAND	2
6	FILLER FOAM	1

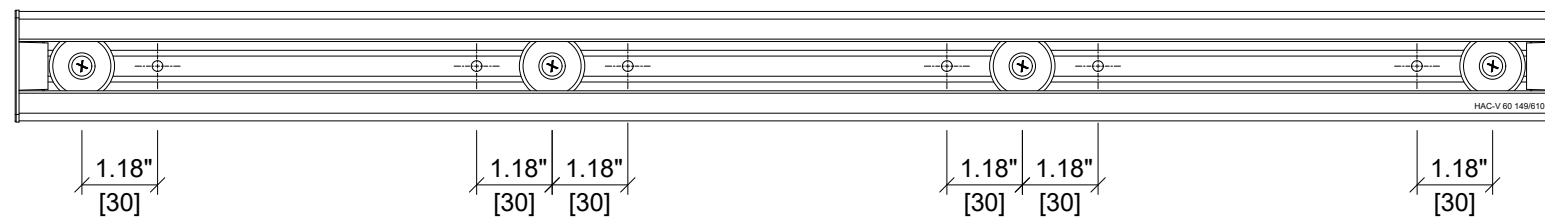
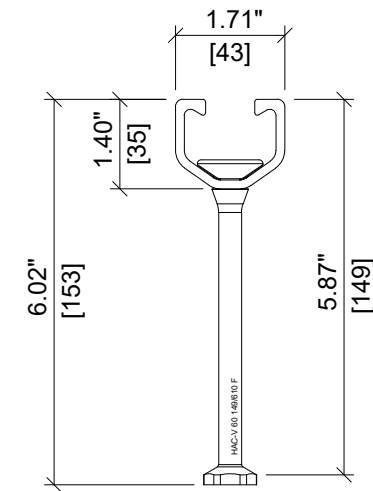
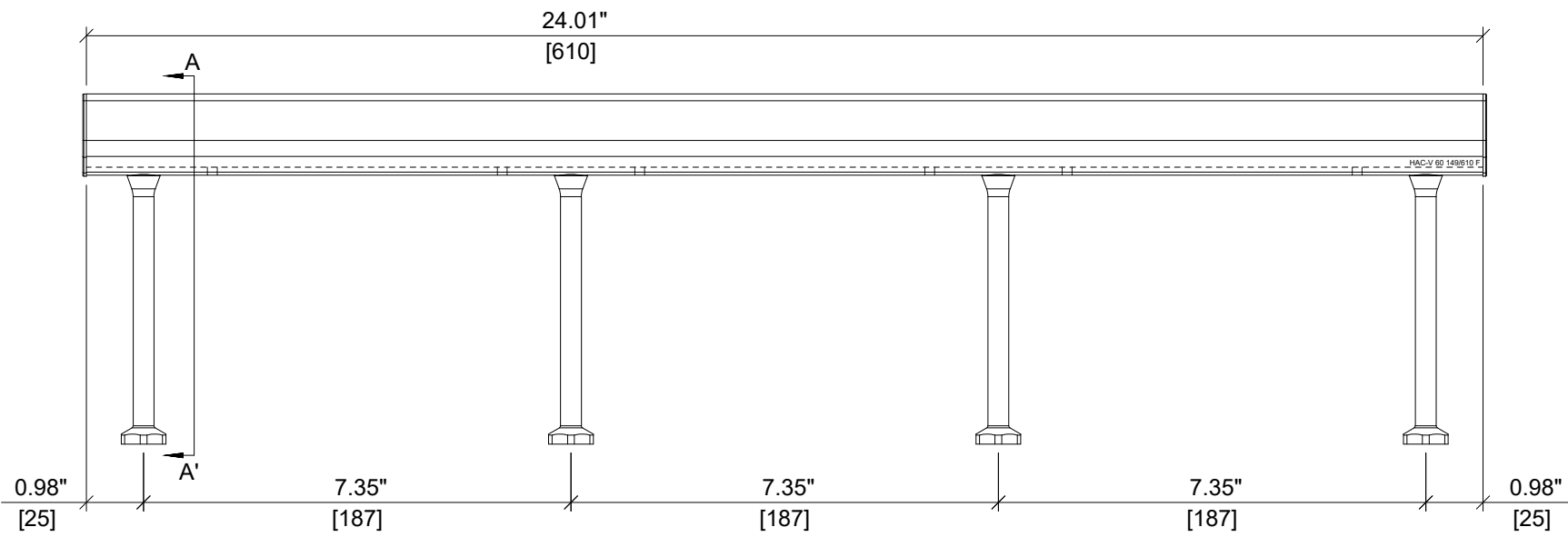

ITEM NUMBER: 2331581	CHANNEL LIP: SMOOTH
--------------------------------	-------------------------------

ITEM DESCRIPTION:
HAC-V 60 149/610 F



ITEM	DESCRIPTION	QUANTITY
1	CHANNEL PROFILE	1
2	RIVET CONNECTION	5
3	ROUNDED HEADED ANCHOR	5
4	END CAP	2
5	TEAR OUT BAND	2
6	FILLER FOAM	1

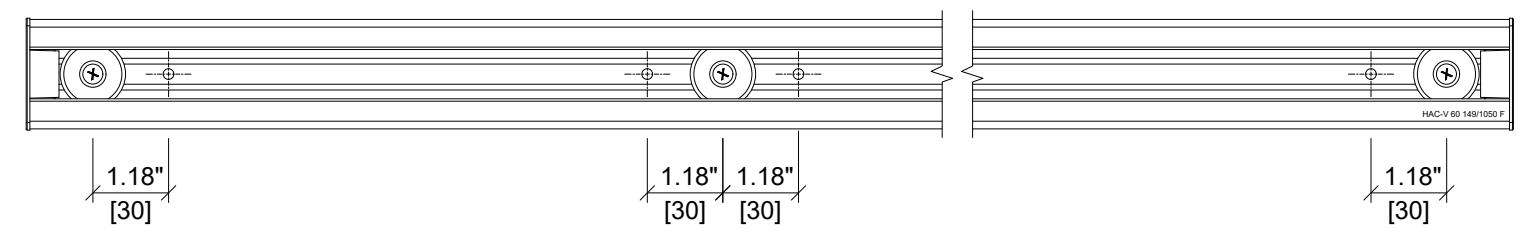
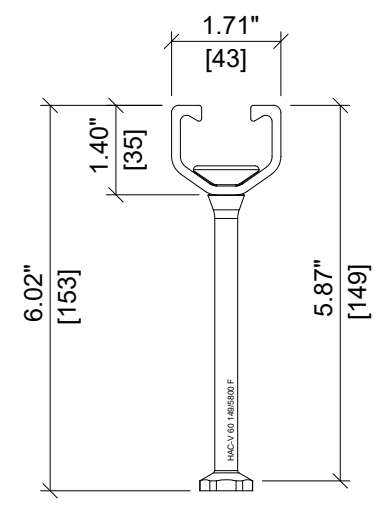
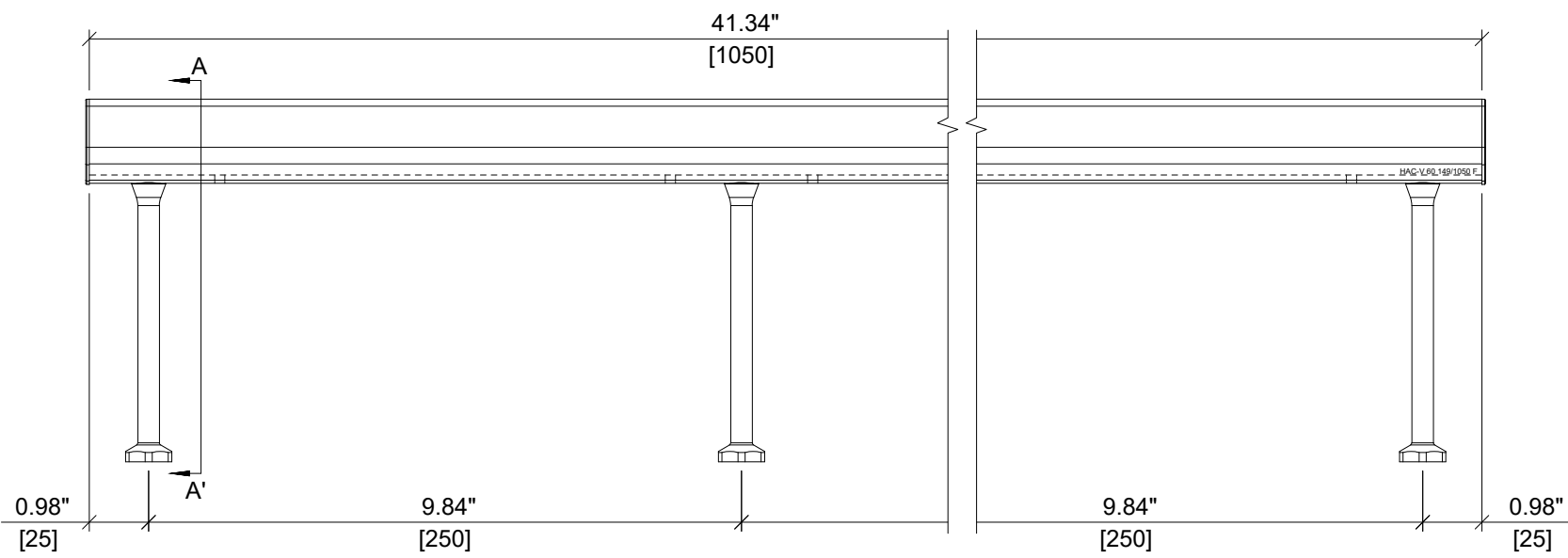

HILTI

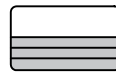
ITEM NUMBER: 2331582 CHANNEL LIP: SMOOTH 

ITEM DESCRIPTION: HAC-V 60 149/1050 F



ITEM	DESCRIPTION	QUANTITY
1	CHANNEL PROFILE	1
2	RIVET CONNECTION	24
3	ROUNDED HEADED ANCHOR	24
4	END CAP	2
5	TEAR OUT BAND	2
6	FILLER FOAM	1

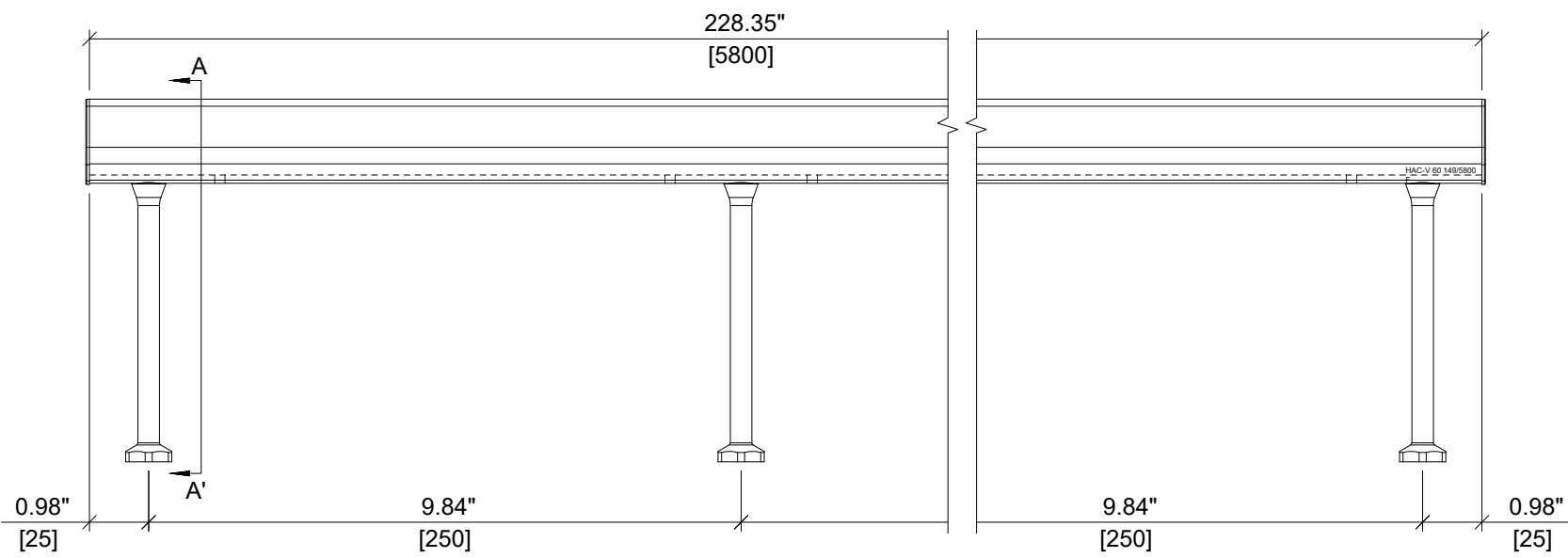

ELEVATION VIEW

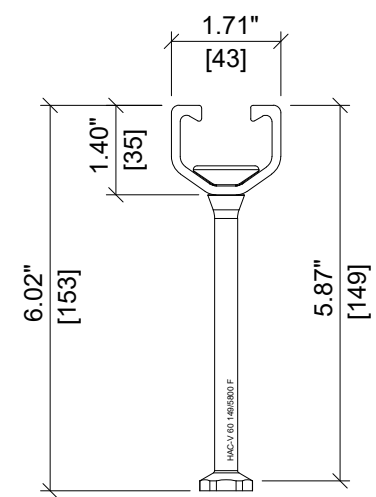

SECTION A-A'

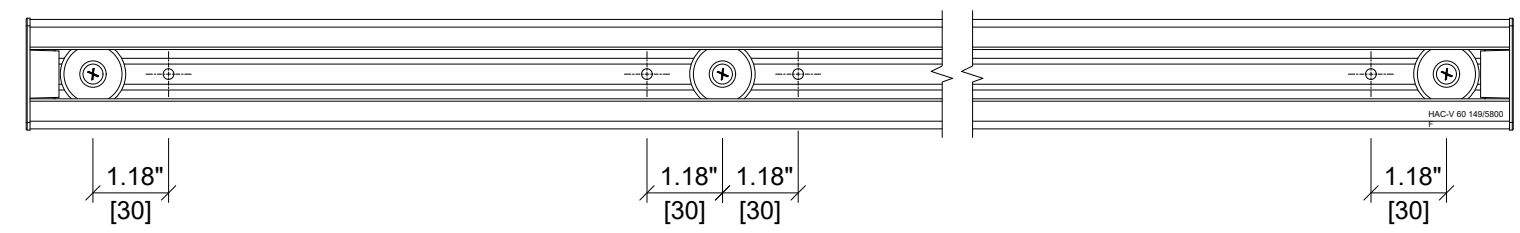

PLAN VIEW

HILTI

ITEM NUMBER: 2331583

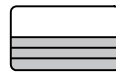
CHANNEL LIP: SMOOTH 

ITEM DESCRIPTION: HAC-V 60 149/5800 F



ITEM	DESCRIPTION	QUANTITY
1	CHANNEL PROFILE	1
2	RIVET CONNECTION	2
3	ROUNDED HEADED ANCHOR	2
4	END CAP	2
5	TEAR OUT BAND	1
6	FILLER FOAM	1

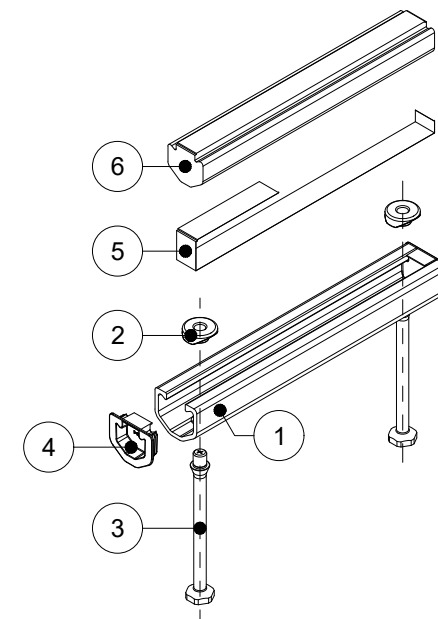
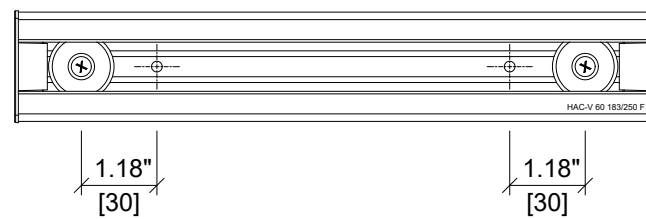
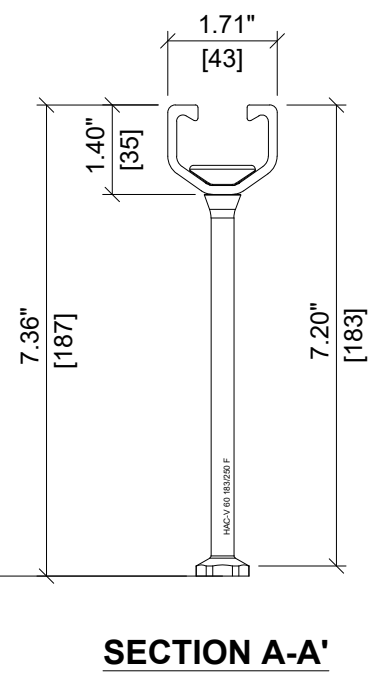
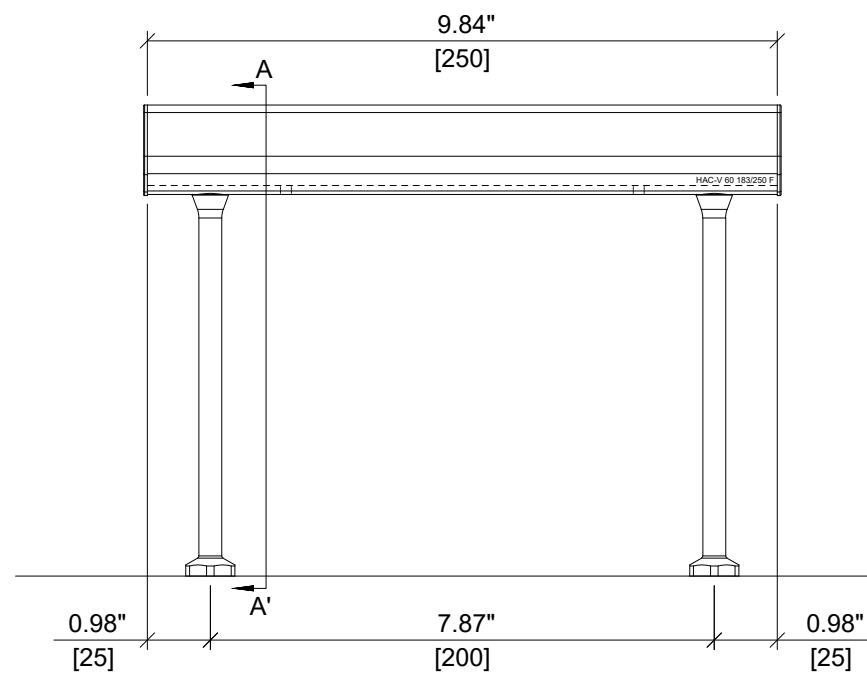

HILTI

ITEM NUMBER: <div style="text-align: center; font-size: 18px; font-weight: bold;">TBD</div>	CHANNEL LIP: <div style="text-align: center; font-size: 18px; font-weight: bold;">SMOOTH</div>
ITEM DESCRIPTION: <div style="text-align: center; font-size: 18px; font-weight: bold;">HAC-V 60 183/250 F</div>	



ITEM	DESCRIPTION	QUANTITY
1	CHANNEL PROFILE	1
2	RIVET CONNECTION	2
3	ROUNDED HEADED ANCHOR	2
4	END CAP	2
5	TEAR OUT BAND	1
6	FILLER FOAM	1

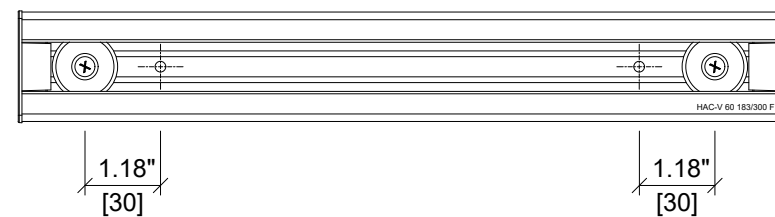
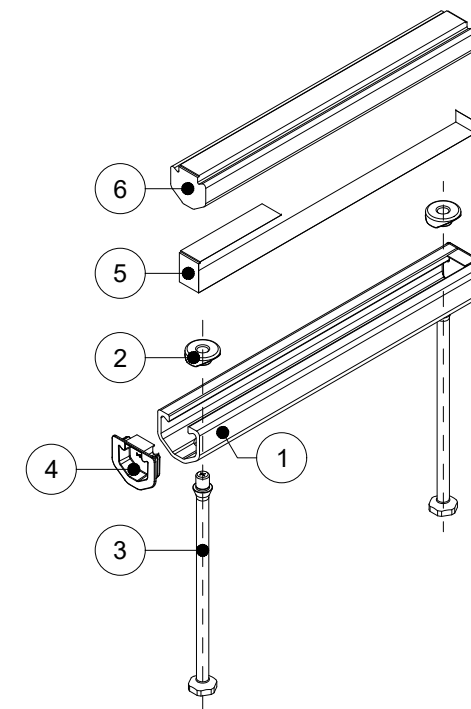
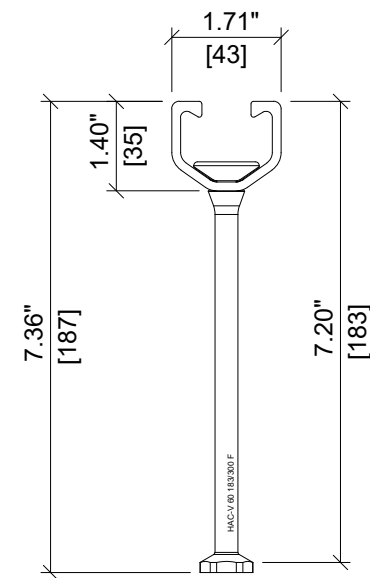
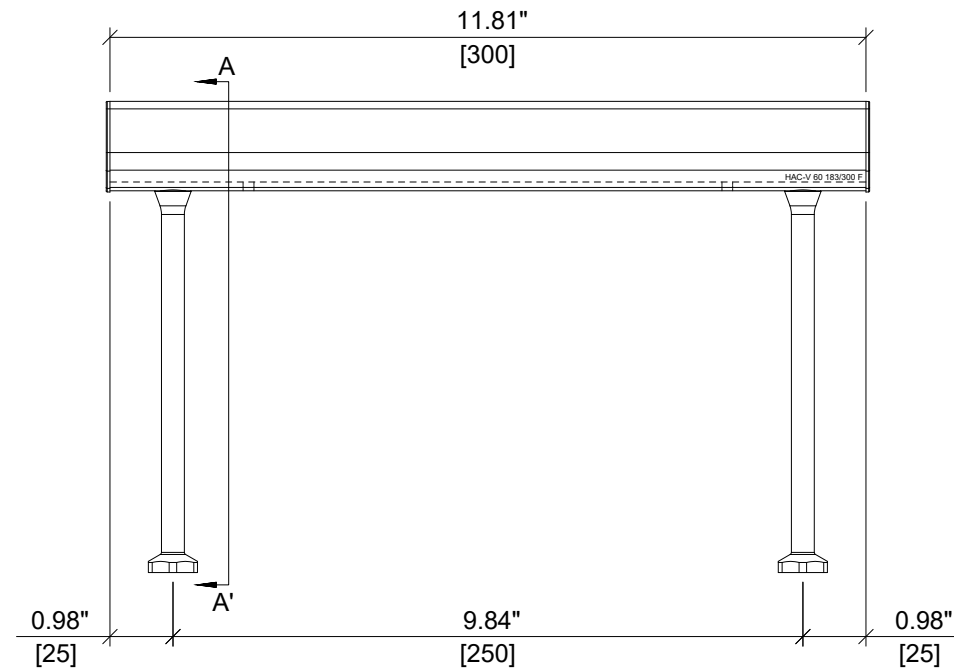

HILTI

ITEM NUMBER: 2331568

CHANNEL LIP: SMOOTH

ITEM DESCRIPTION: HAC-V 60 183/300 F



ITEM	DESCRIPTION	QUANTITY
1	CHANNEL PROFILE	1
2	RIVET CONNECTION	3
3	ROUNDED HEADED ANCHOR	3
4	END CAP	2
5	TEAR OUT BAND	1
6	FILLER FOAM	1

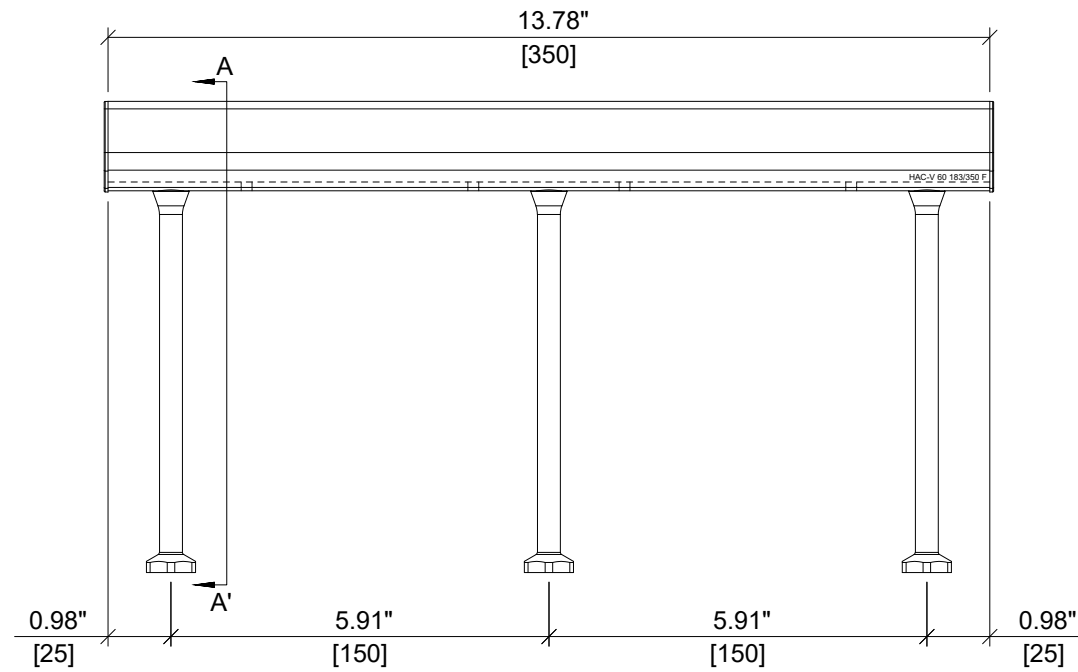

ELEVATION VIEW

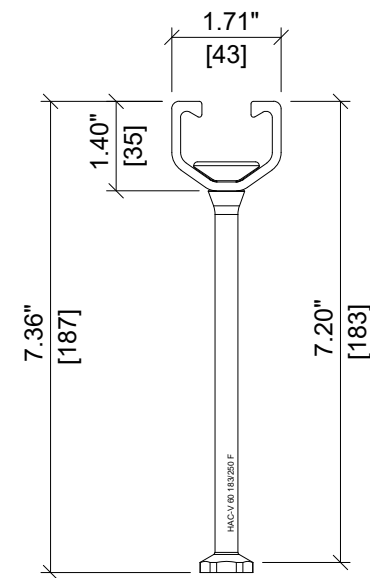

SECTION A-A'

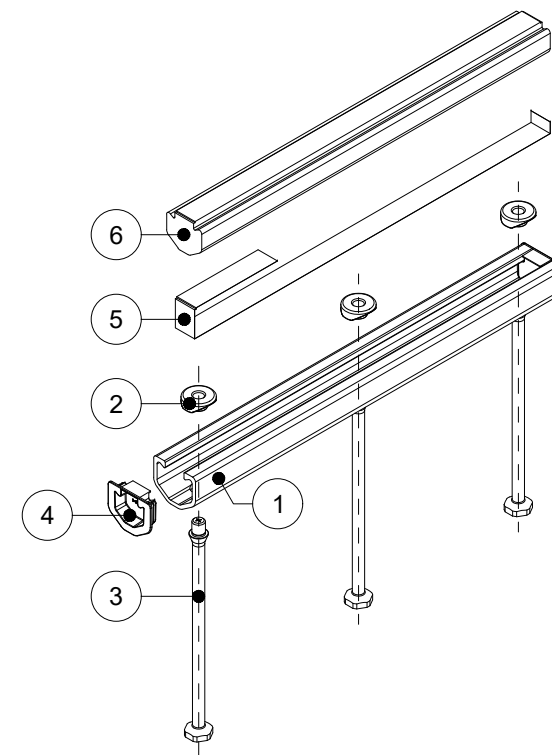

ISOMETRIC VIEW

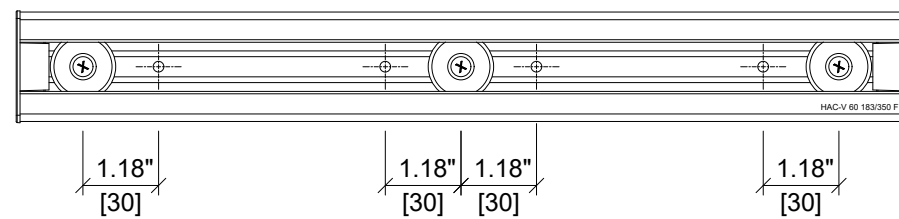

PLAN VIEW

HILTI

ITEM NUMBER: <div style="font-size: 18px; font-weight: bold;">2331569</div>	CHANNEL LIP: <div style="font-size: 18px; font-weight: bold;">SMOOTH</div>
ITEM DESCRIPTION: <div style="font-size: 18px; font-weight: bold;">HAC-V 60 183/350 F</div>	



ITEM	DESCRIPTION	QUANTITY
1	CHANNEL PROFILE	1
2	RIVET CONNECTION	3
3	ROUNDED HEADED ANCHOR	3
4	END CAP	2
5	TEAR OUT BAND	1
6	FILLER FOAM	1

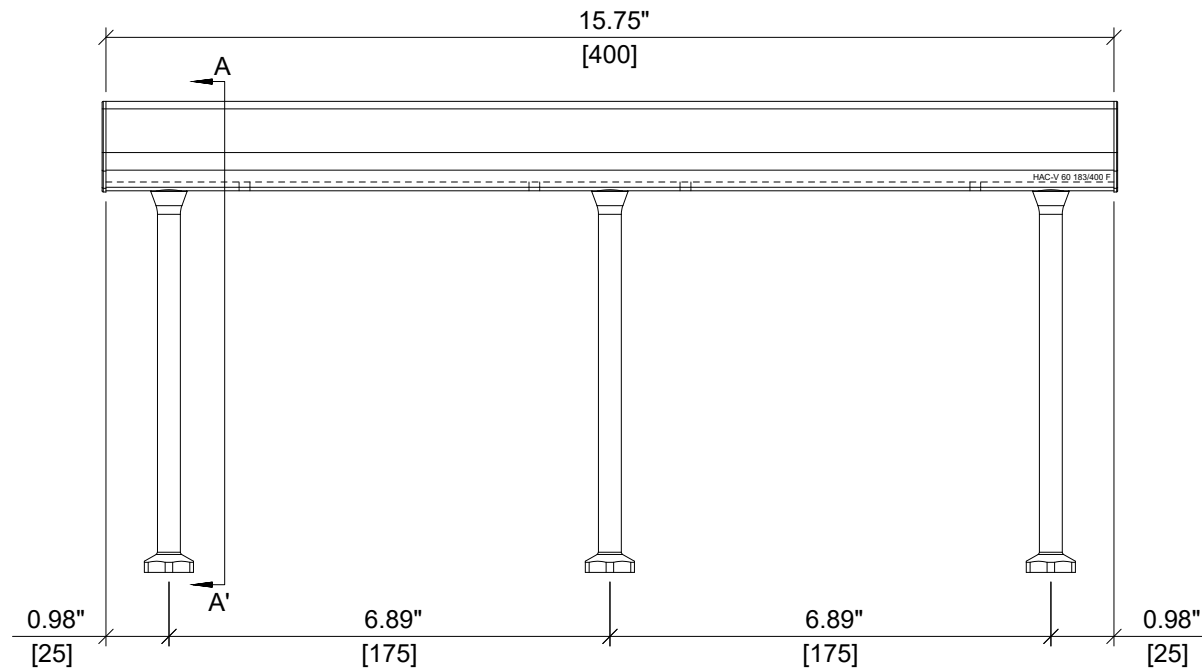

ELEVATION VIEW

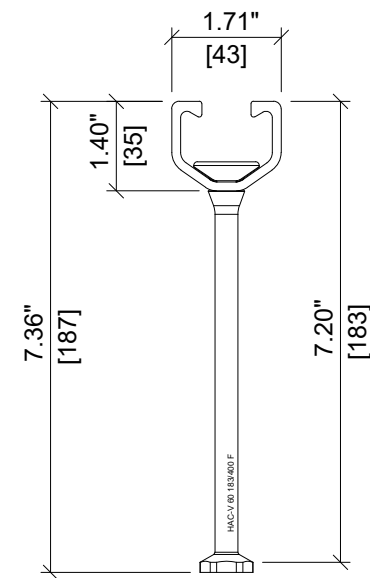

SECTION A-A'

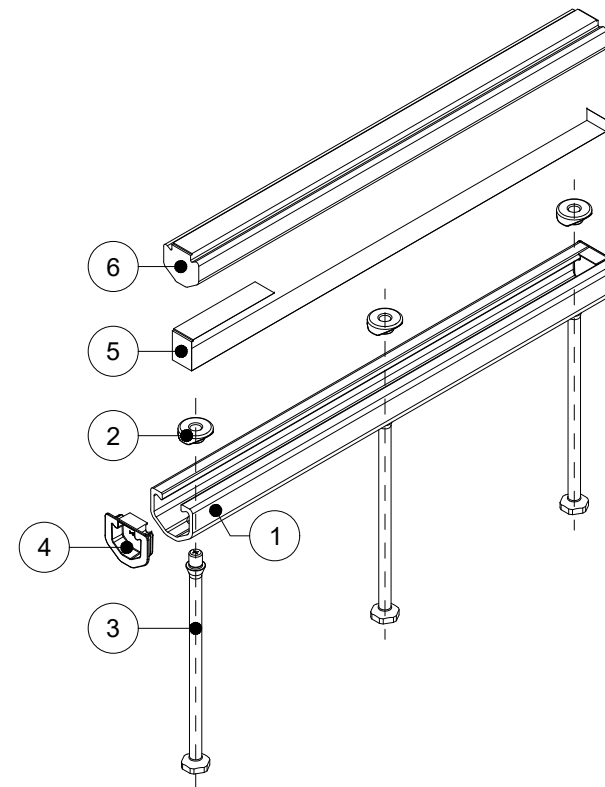

ISOMETRIC VIEW

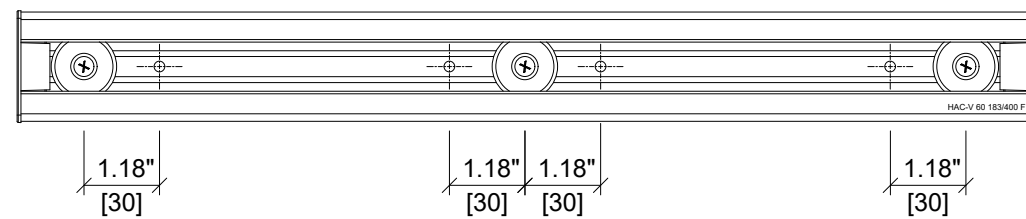

PLAN VIEW

HILTI

ITEM NUMBER: <div style="font-size: 18px; font-weight: bold;">2331570</div>	CHANNEL LIP: <div style="font-size: 18px; font-weight: bold;">SMOOTH</div>
ITEM DESCRIPTION: <div style="font-size: 18px; font-weight: bold;">HAC-V 60 183/400 F</div>	



ITEM	DESCRIPTION	QUANTITY
1	CHANNEL PROFILE	1
2	RIVET CONNECTION	3
3	ROUNDED HEADED ANCHOR	3
4	END CAP	2
5	TEAR OUT BAND	1
6	FILLER FOAM	1

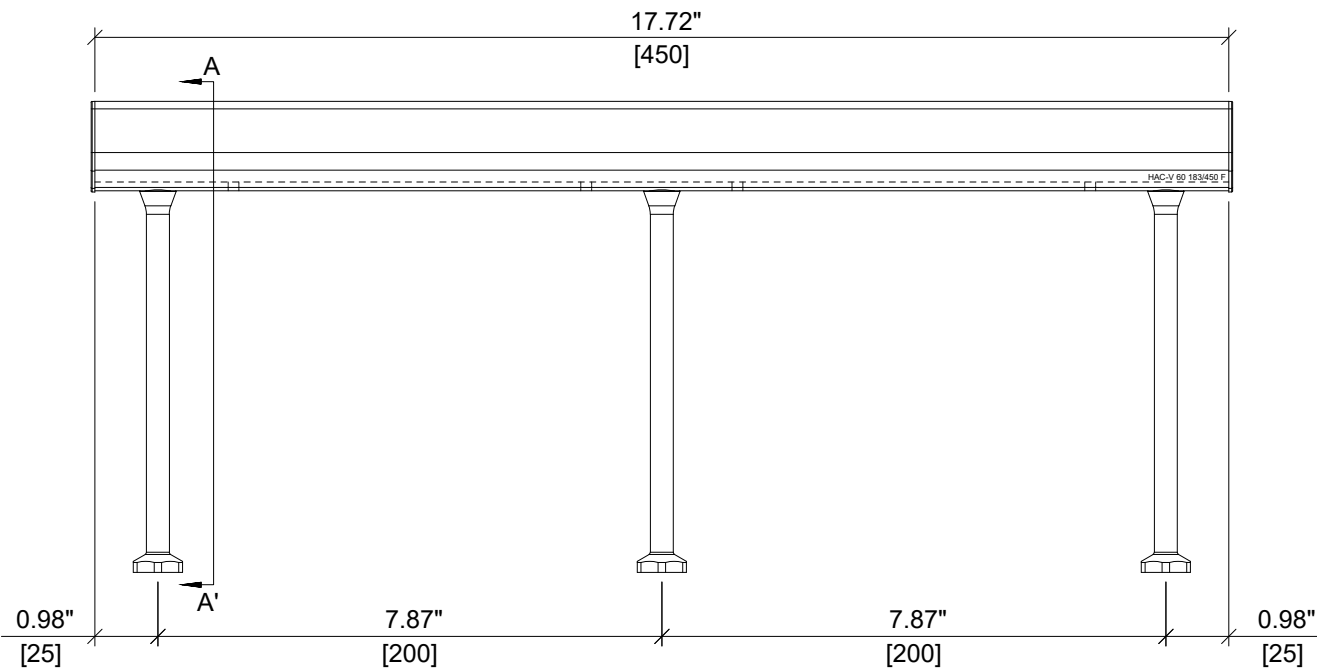

ELEVATION VIEW

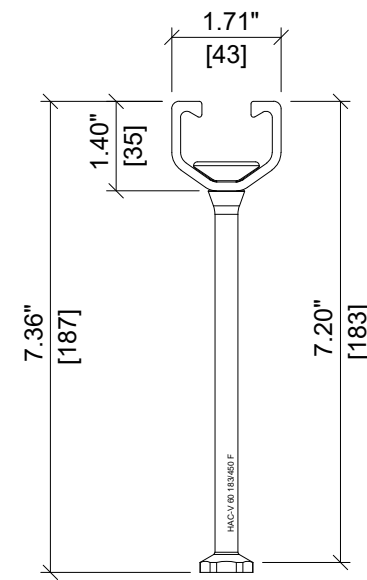

SECTION A-A'

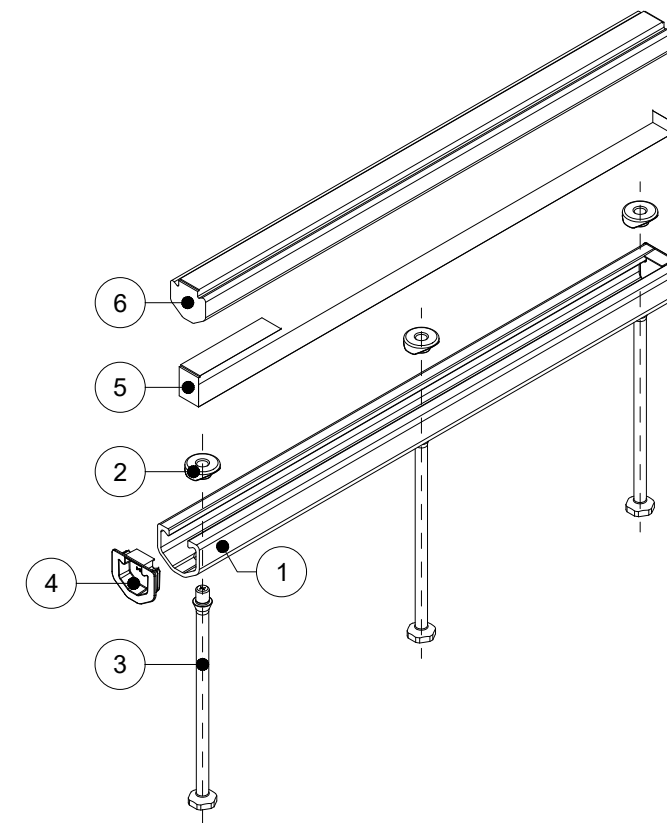

ISOMETRIC VIEW

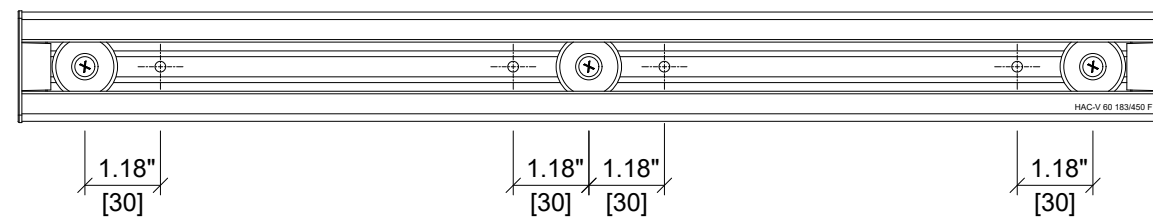

PLAN VIEW



ITEM NUMBER: 2331571	CHANNEL LIP: SMOOTH
--------------------------------	-------------------------------

ITEM DESCRIPTION: HAC-V 60 183/450 F
--



ITEM	DESCRIPTION	QUANTITY
1	CHANNEL PROFILE	1
2	RIVET CONNECTION	3
3	ROUNDED HEADED ANCHOR	3
4	END CAP	2
5	TEAR OUT BAND	1
6	FILLER FOAM	1

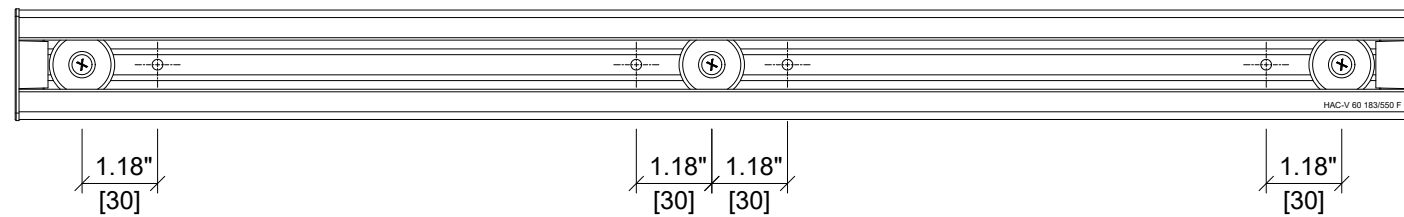
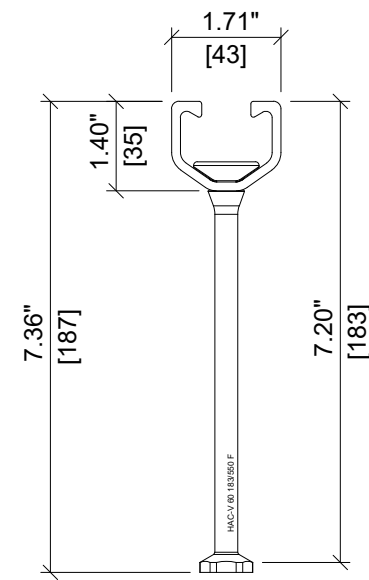
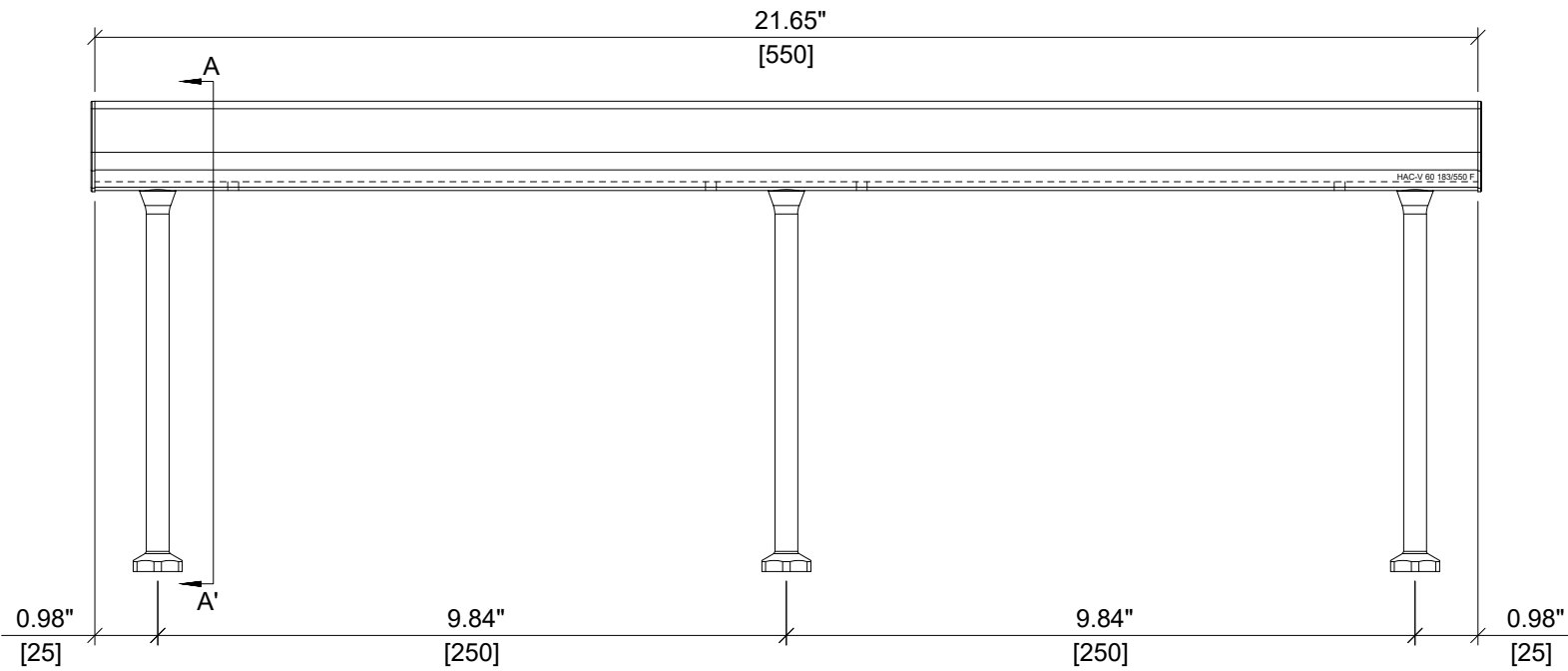

ITEM NUMBER: 2331572	CHANNEL LIP: SMOOTH
--------------------------------	-------------------------------

ITEM DESCRIPTION:
HAC-V 60 183/550 F



ITEM	DESCRIPTION	QUANTITY
1	CHANNEL PROFILE	1
2	RIVET CONNECTION	4
3	ROUNDED HEADED ANCHOR	4
4	END CAP	2
5	TEAR OUT BAND	2
6	FILLER FOAM	1

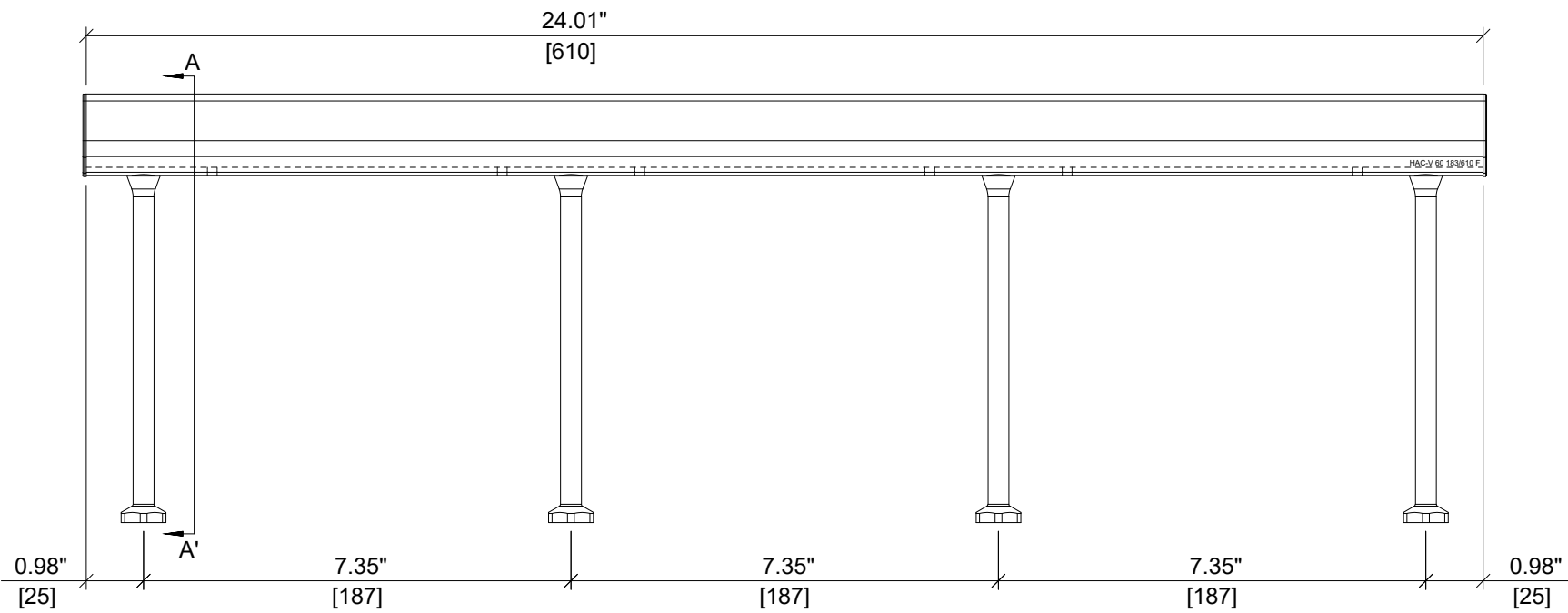

ELEVATION VIEW

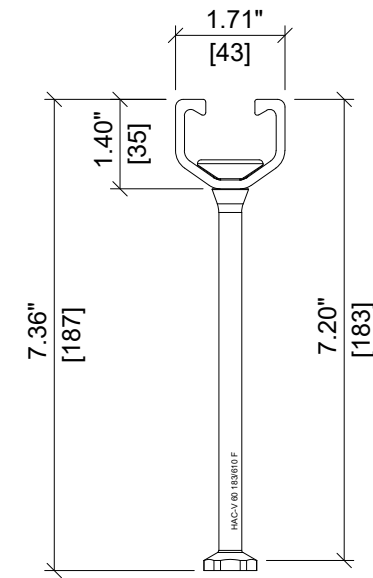

SECTION A-A'

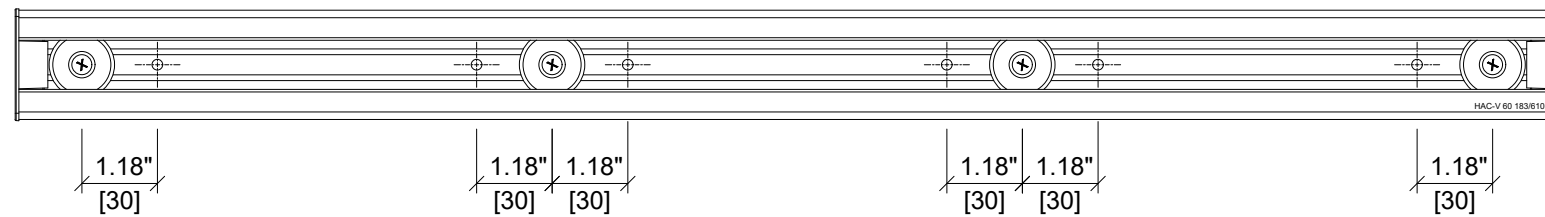

PLAN VIEW



ITEM NUMBER: 2331573	CHANNEL LIP: SMOOTH
ITEM DESCRIPTION: HAC-V 60 183/610 F	



ITEM	DESCRIPTION	QUANTITY
1	CHANNEL PROFILE	1
2	RIVET CONNECTION	5
3	ROUNDED HEADED ANCHOR	5
4	END CAP	2
5	TEAR OUT BAND	2
6	FILLER FOAM	1

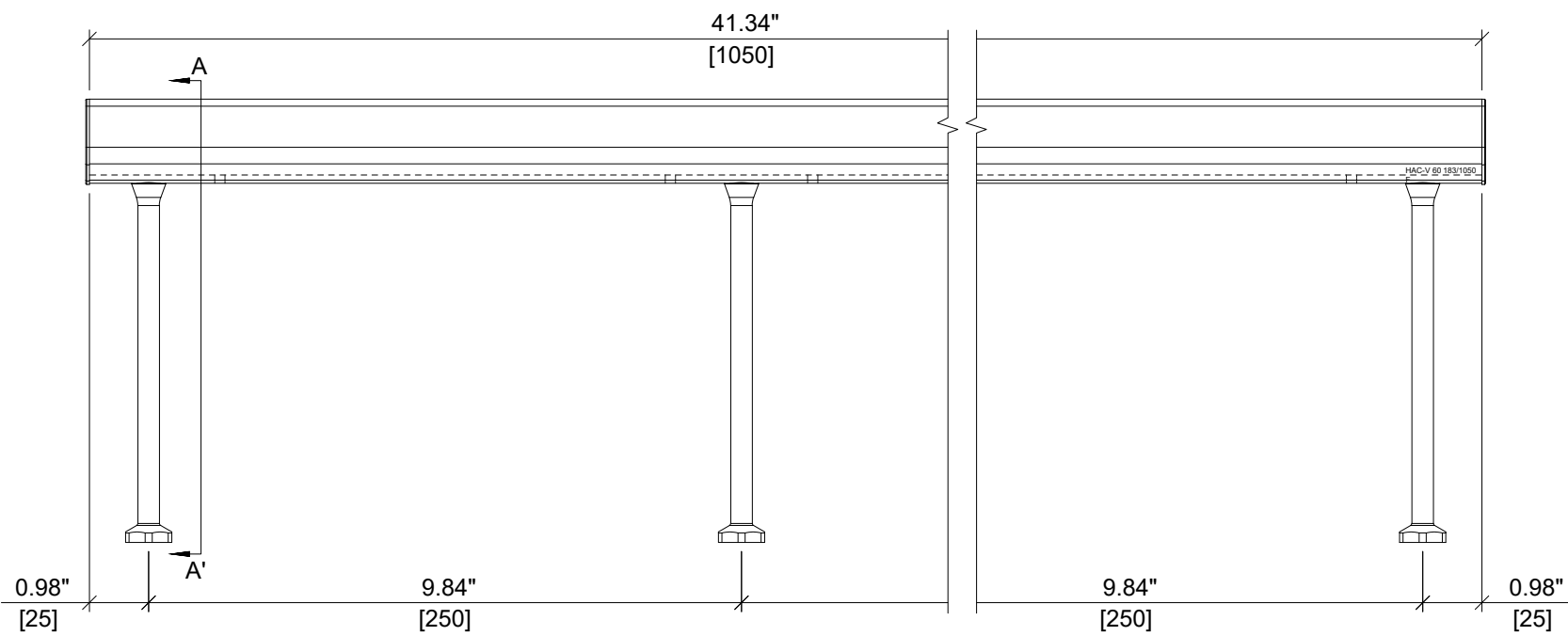

ELEVATION VIEW

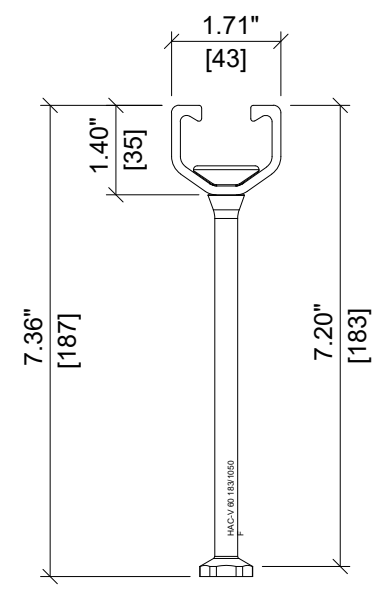

SECTION A-A'

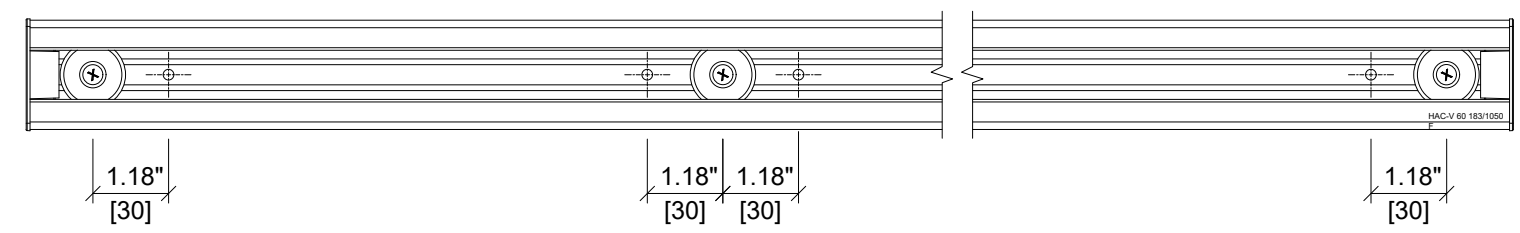

HILTI

ITEM NUMBER: <div style="font-size: 18px; font-weight: bold; text-align: center;">2331574</div>	CHANNEL LIP: <div style="font-size: 18px; font-weight: bold; text-align: center;">SMOOTH</div> <div style="text-align: right; margin-top: 5px;"> </div>
ITEM DESCRIPTION: <div style="font-size: 18px; font-weight: bold; text-align: center;">HAC-V 60 183/1050 F</div>	

ITEM	DESCRIPTION	QUANTITY
1	CHANNEL PROFILE	1
2	RIVET CONNECTION	24
3	ROUNDED HEADED ANCHOR	24
4	END CAP	2
5	TEAR OUT BAND	2
6	FILLER FOAM	1

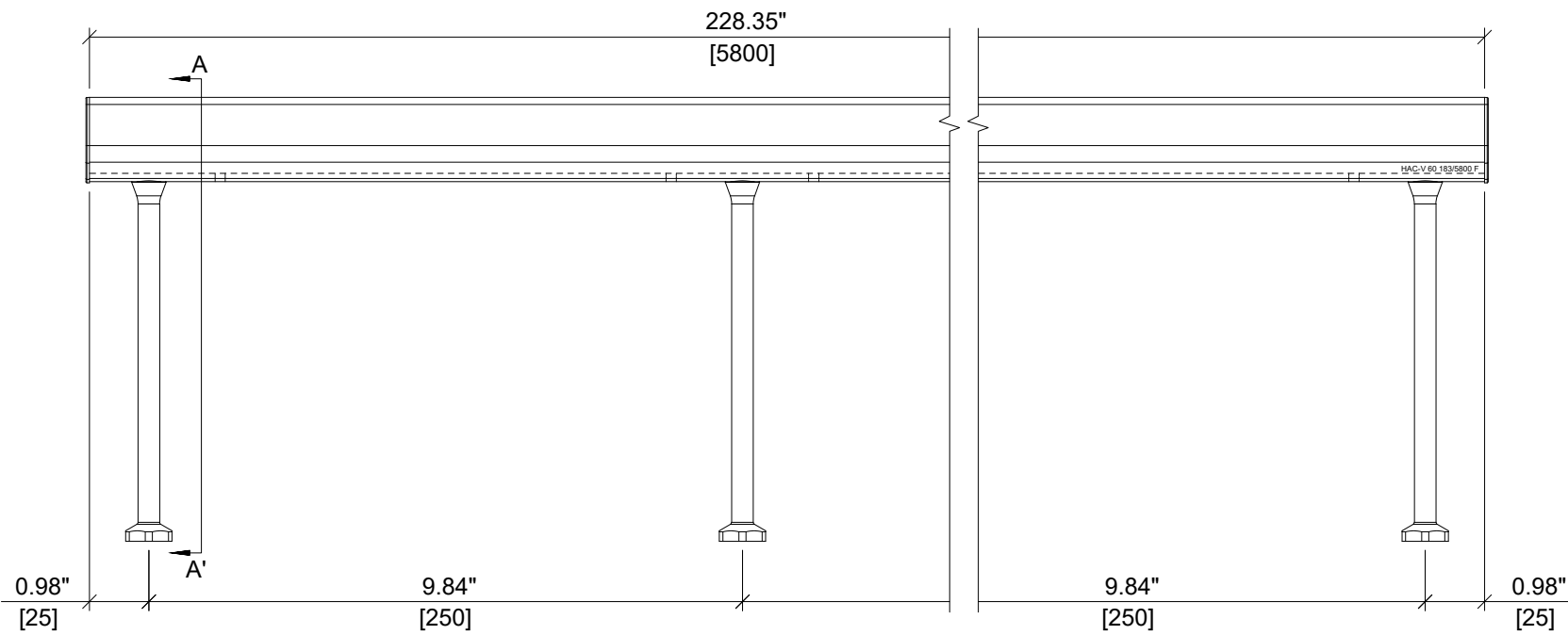

ELEVATION VIEW

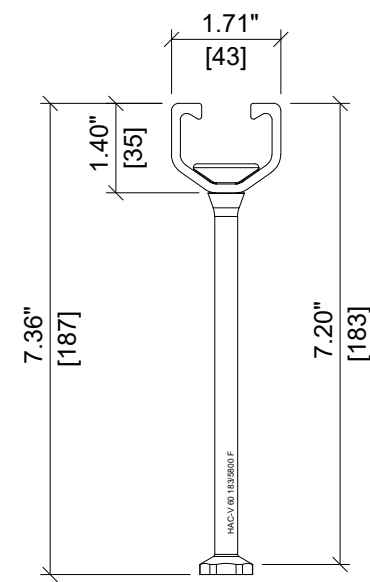

SECTION A-A'

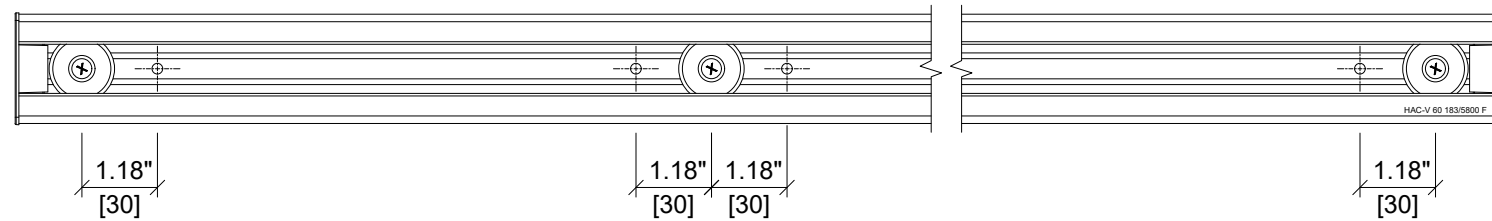

ITEM NUMBER: 2331575	CHANNEL LIP: SMOOTH
ITEM DESCRIPTION: HAC-V 60 183/5800 F	

ITEM	DESCRIPTION	QUANTITY
1	CHANNEL PROFILE	1
2	RIVET CONNECTION	2
3	ROUNDED HEADED ANCHOR	2
4	END CAP	2
5	TEAR OUT BAND	1
6	FILLER FOAM	1

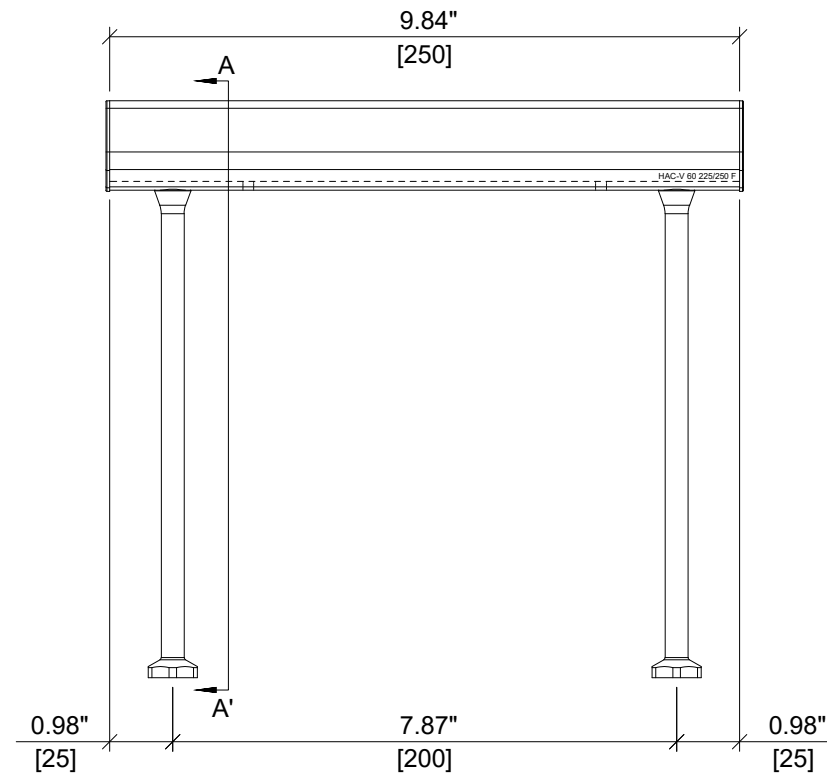

ELEVATION VIEW

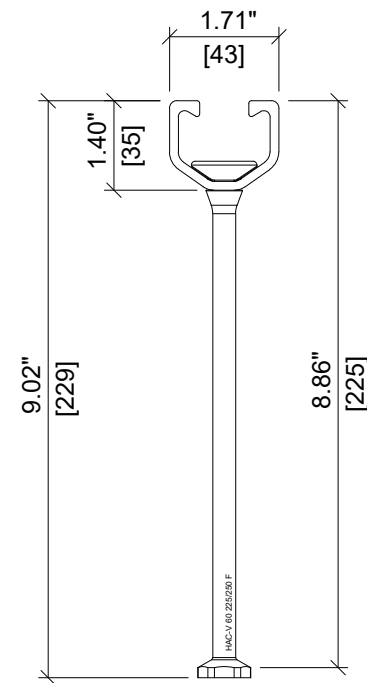

SECTION A-A'

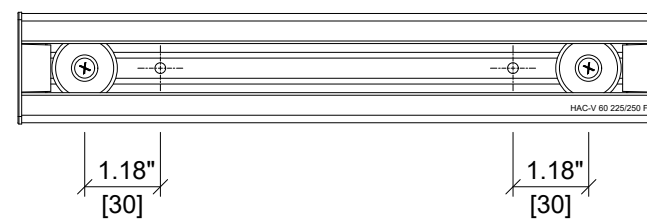

PLAN VIEW

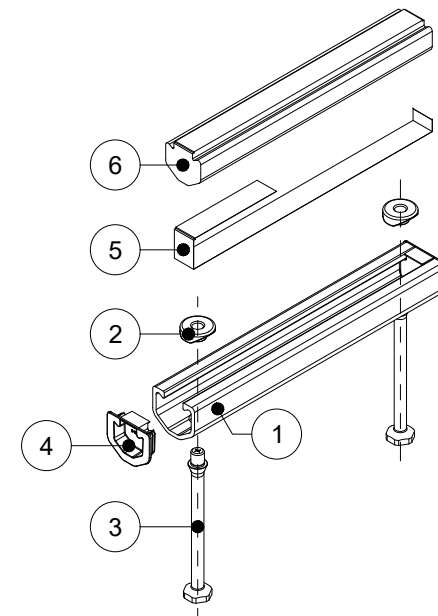

ISOMETRIC VIEW



ITEM NUMBER: TBD	CHANNEL LIP: SMOOTH
----------------------------	-------------------------------

ITEM DESCRIPTION:
HAC-V 60 225/250 F



ITEM	DESCRIPTION	QUANTITY
1	CHANNEL PROFILE	1
2	RIVET CONNECTION	2
3	ROUNDED HEADED ANCHOR	2
4	END CAP	2
5	TEAR OUT BAND	1
6	FILLER FOAM	1

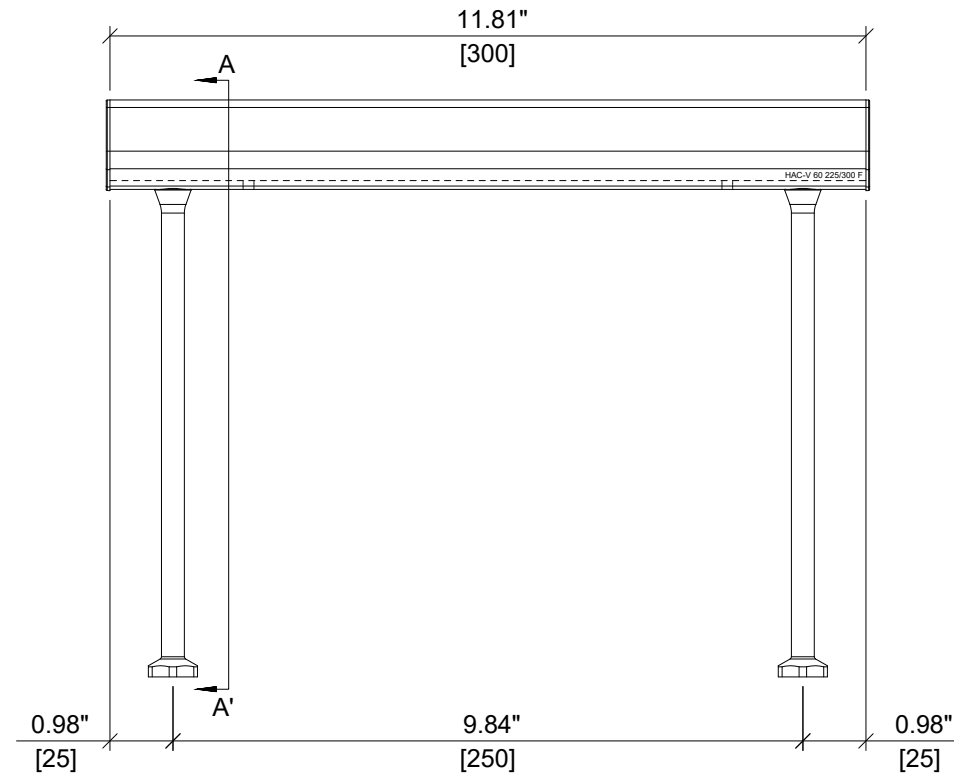

ELEVATION VIEW

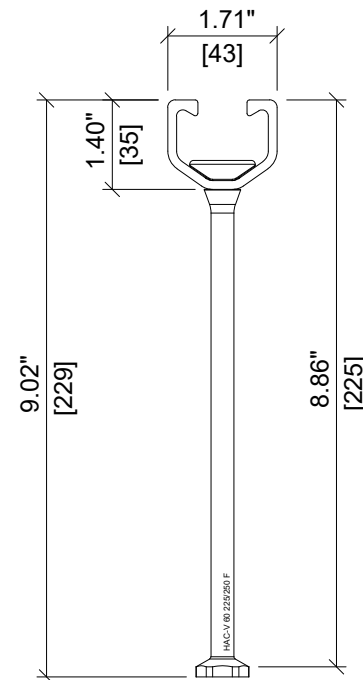

SECTION A-A'

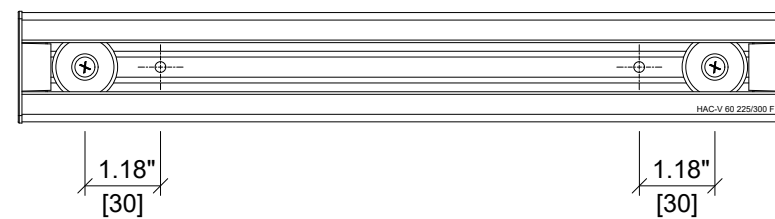

PLAN VIEW

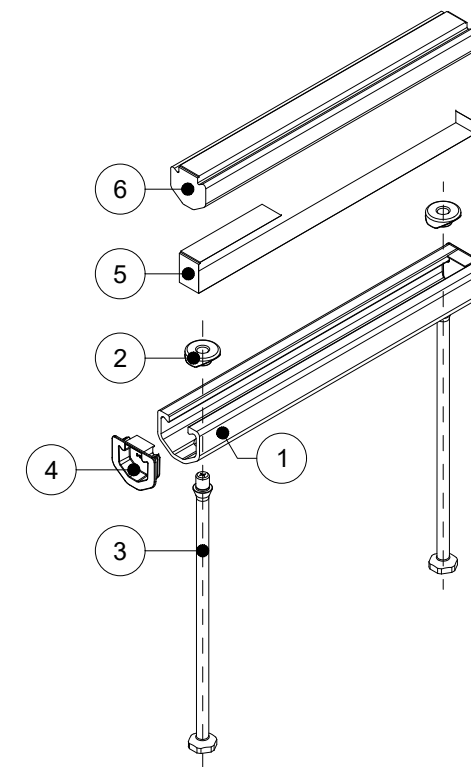

ISOMETRIC VIEW

HILTI

ITEM NUMBER: <div style="font-size: 18px; font-weight: bold; text-align: center;">2331560</div>	CHANNEL LIP: <div style="font-size: 18px; font-weight: bold; text-align: center;">SMOOTH</div> <div style="text-align: right; margin-top: 5px;"> </div>
ITEM DESCRIPTION: <div style="font-size: 18px; font-weight: bold; text-align: center;">HAC-V 60 225/300 F</div>	



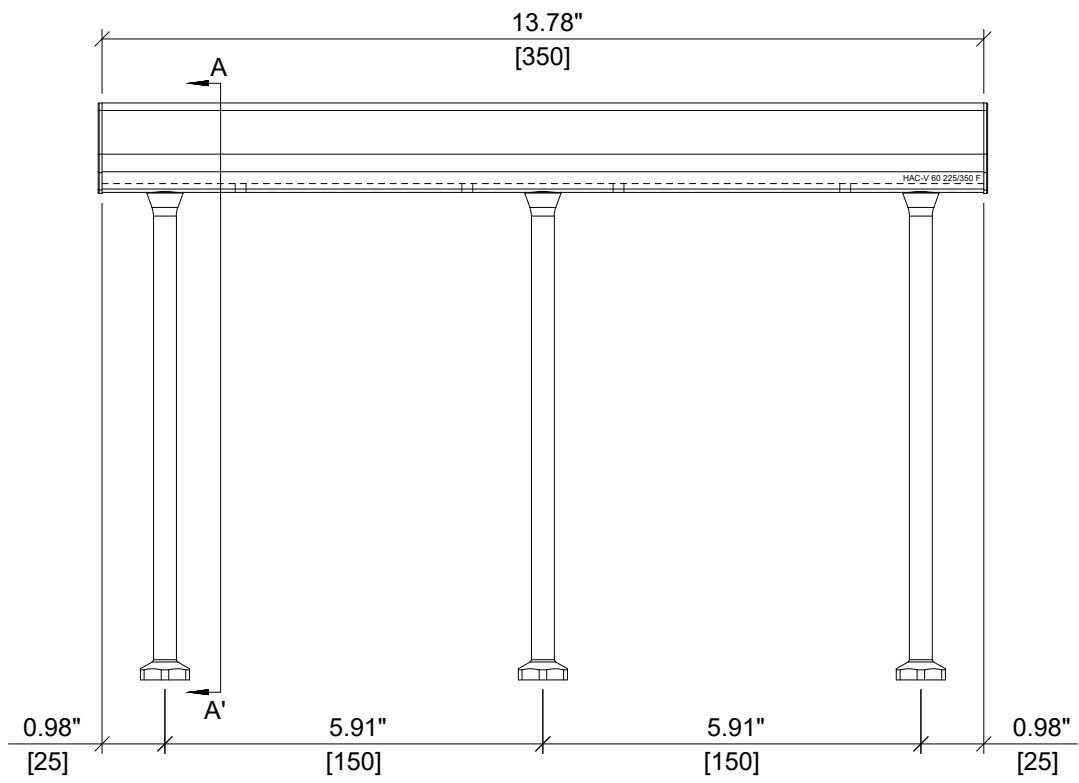

ELEVATION VIEW

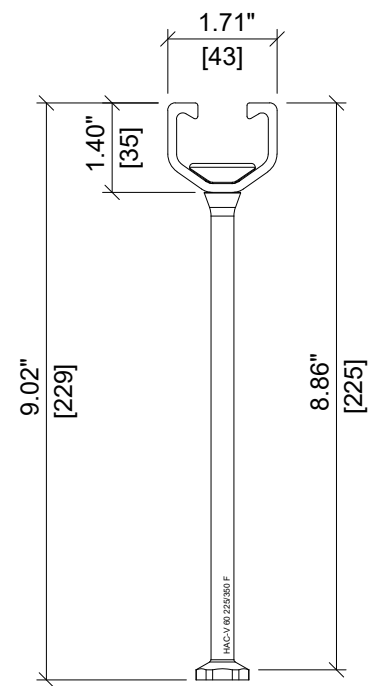

SECTION A-A'

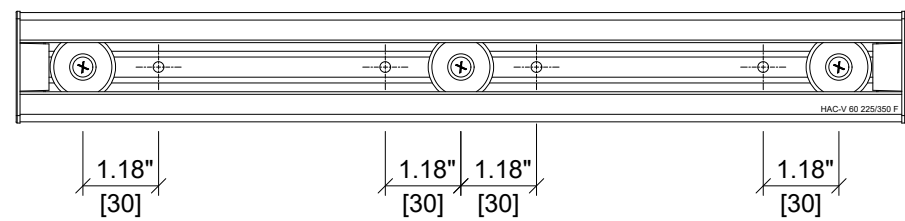

PLAN VIEW

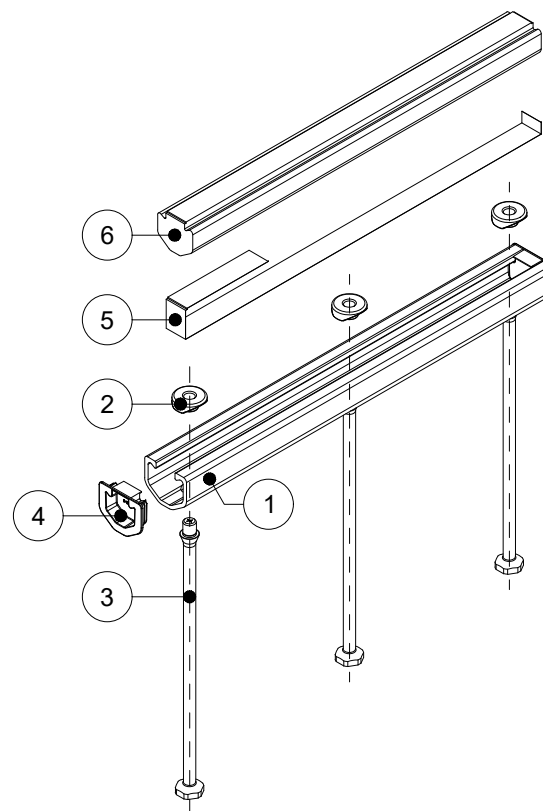

ISOMETRIC VIEW

ITEM	DESCRIPTION	QUANTITY
1	CHANNEL PROFILE	1
2	RIVET CONNECTION	3
3	ROUNDED HEADED ANCHOR	3
4	END CAP	2
5	TEAR OUT BAND	1
6	FILLER FOAM	1

HILTI

ITEM NUMBER: 2331561

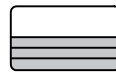
CHANNEL LIP: SMOOTH 

ITEM DESCRIPTION: HAC-V 60 225/350 F



ITEM	DESCRIPTION	QUANTITY
1	CHANNEL PROFILE	1
2	RIVET CONNECTION	3
3	ROUNDED HEADED ANCHOR	3
4	END CAP	2
5	TEAR OUT BAND	1
6	FILLER FOAM	1

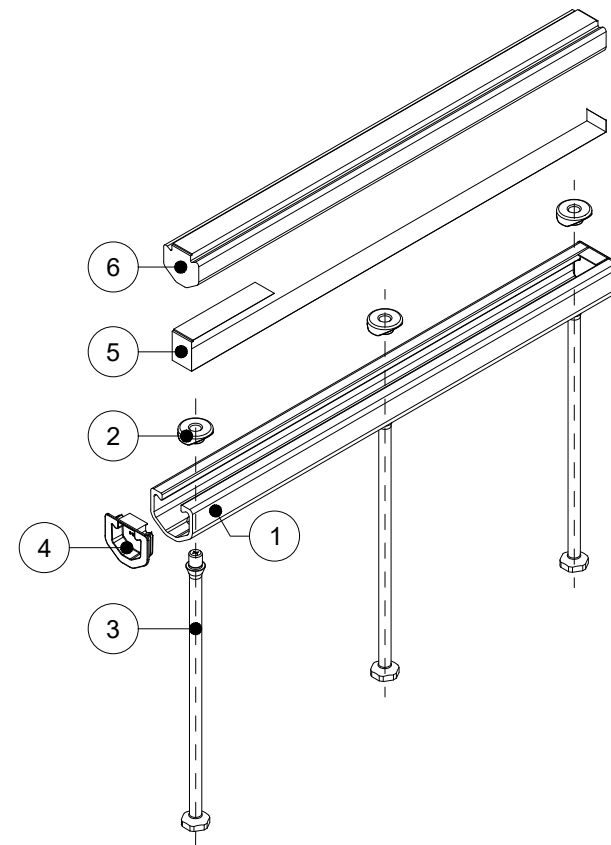
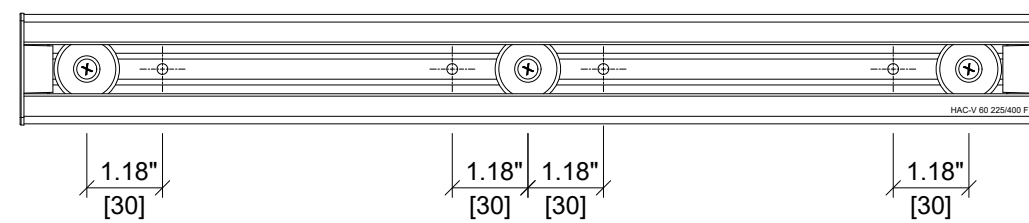
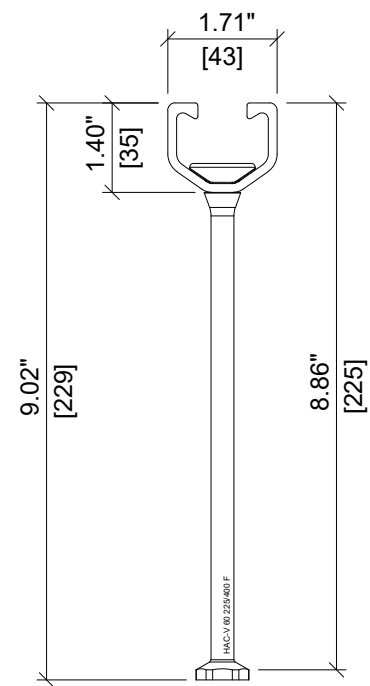
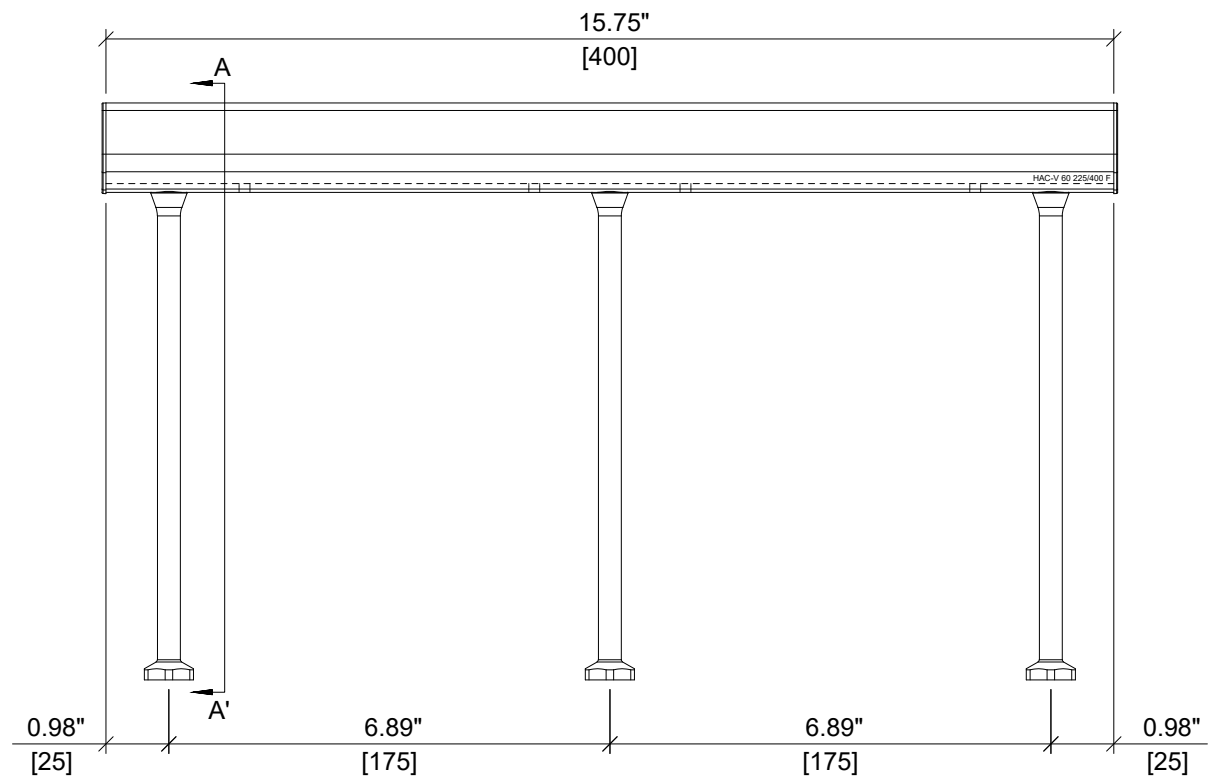

HILTI

ITEM NUMBER: 2331562

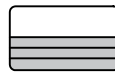
CHANNEL LIP: SMOOTH 

ITEM DESCRIPTION: HAC-V 60 225/400 F



ITEM	DESCRIPTION	QUANTITY
1	CHANNEL PROFILE	1
2	RIVET CONNECTION	3
3	ROUNDED HEADED ANCHOR	3
4	END CAP	2
5	TEAR OUT BAND	1
6	FILLER FOAM	1

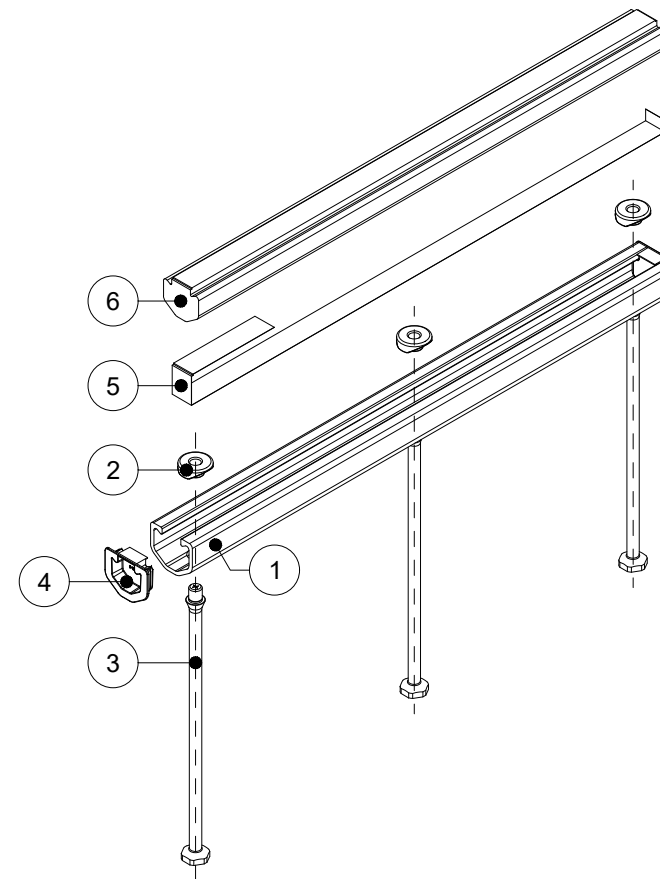
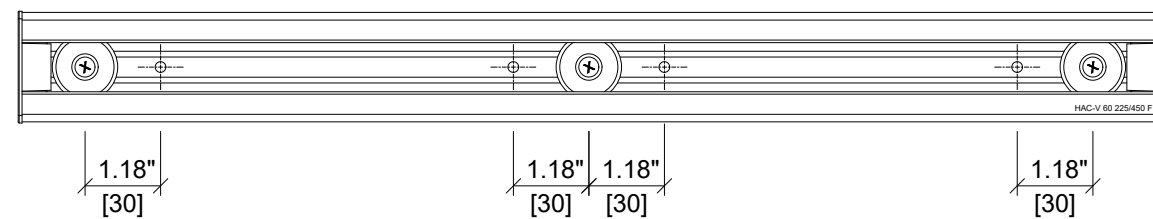
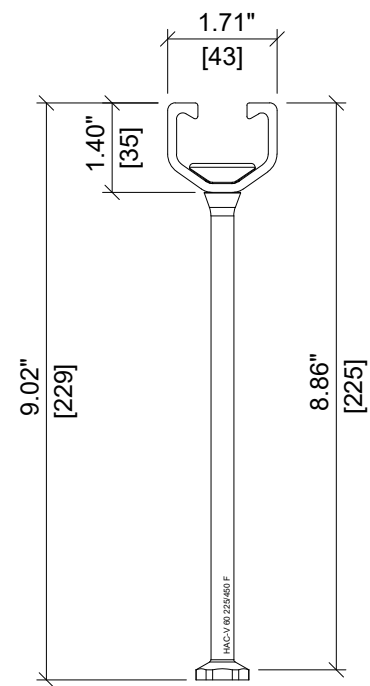
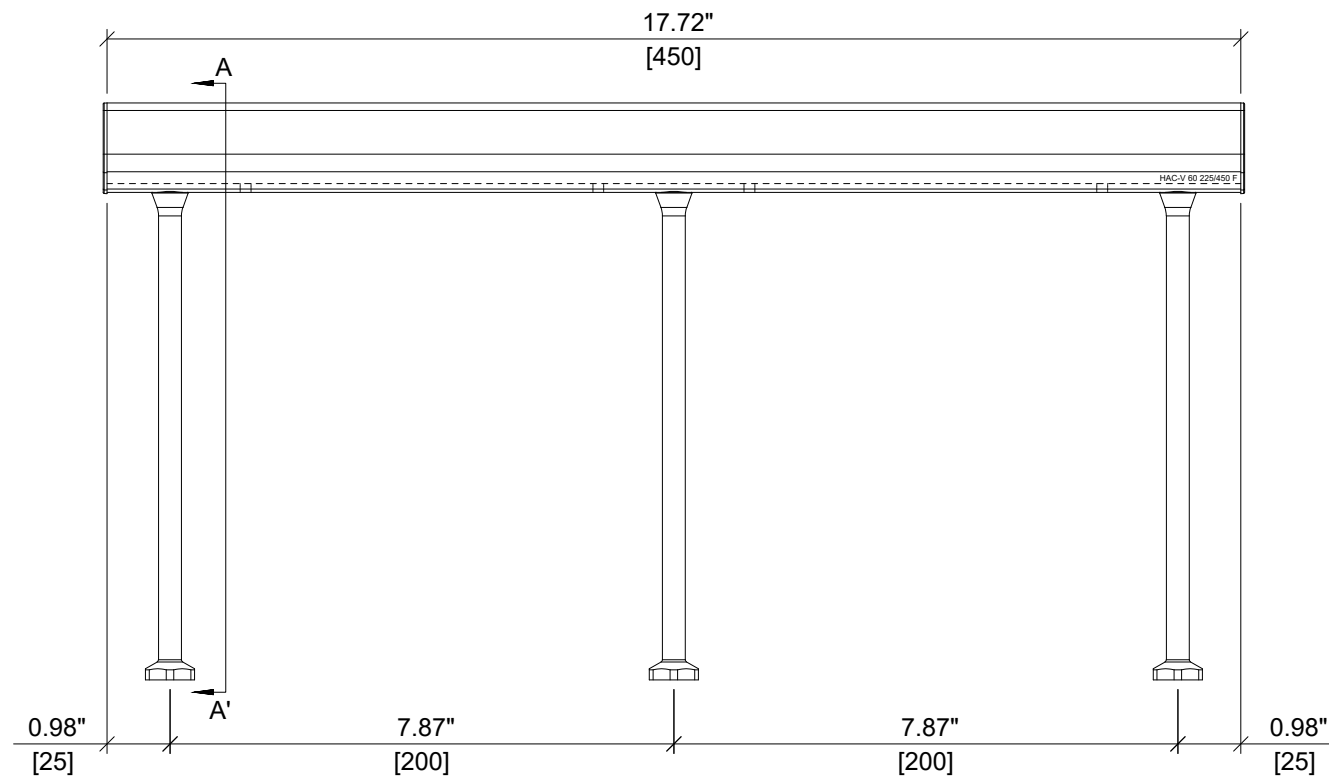

HILTI

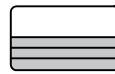
ITEM NUMBER: 2331563 CHANNEL LIP: SMOOTH 

ITEM DESCRIPTION: HAC-V 60 225/450 F



ITEM	DESCRIPTION	QUANTITY
1	CHANNEL PROFILE	1
2	RIVET CONNECTION	3
3	ROUNDED HEADED ANCHOR	3
4	END CAP	2
5	TEAR OUT BAND	1
6	FILLER FOAM	1

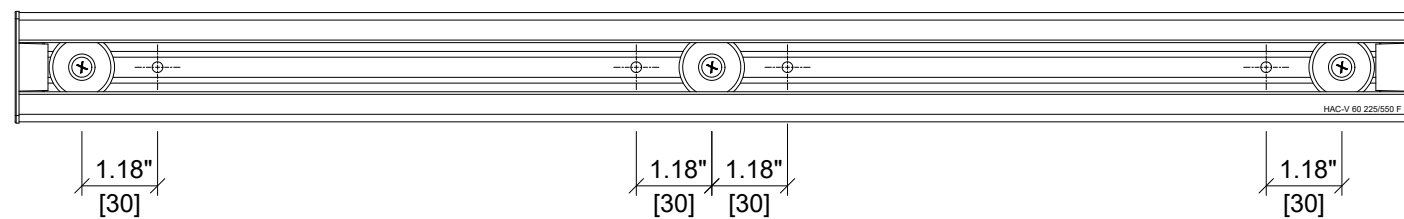
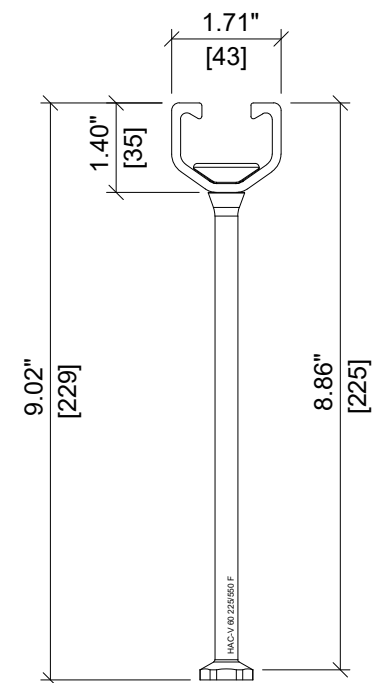
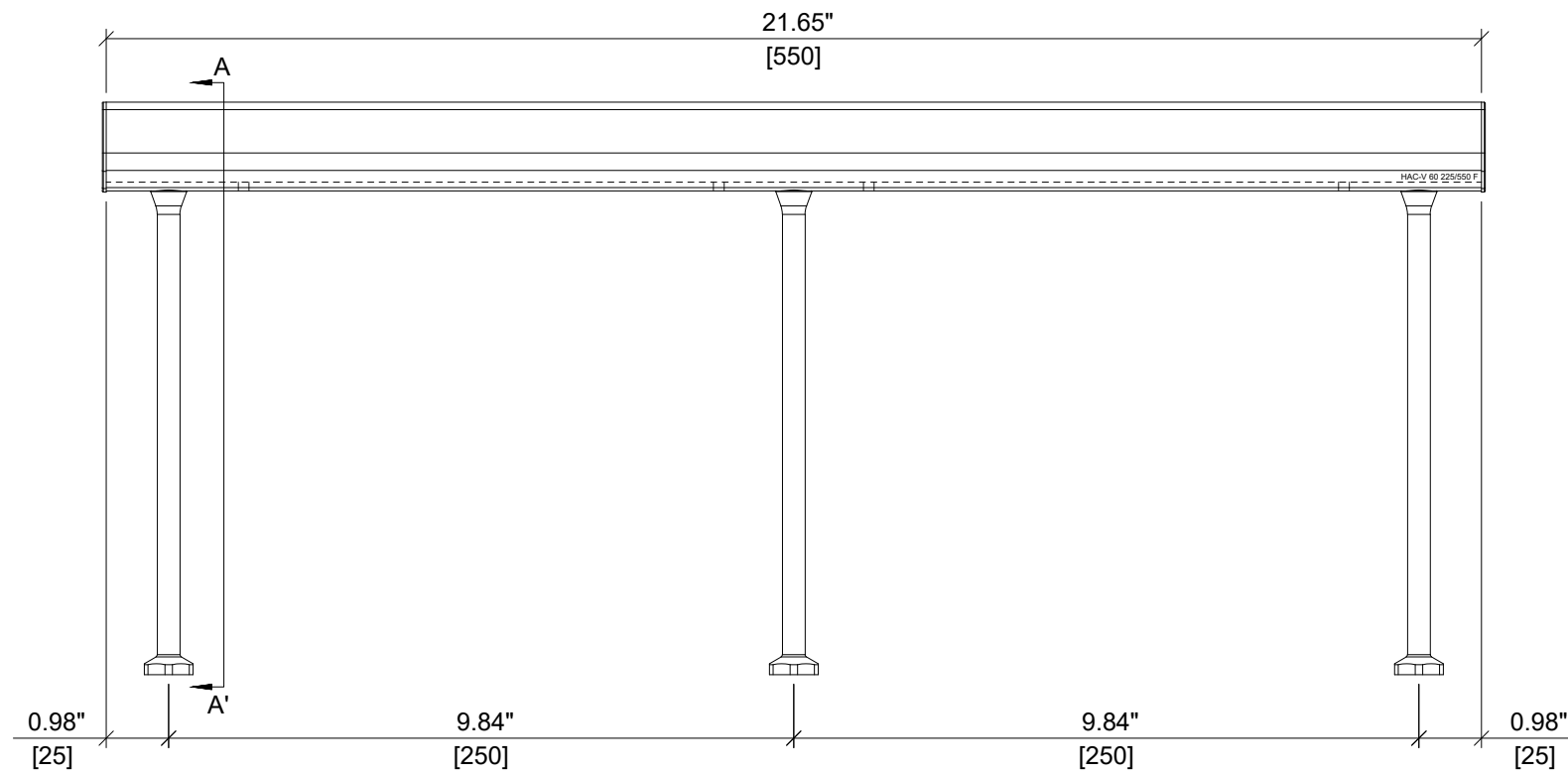

HILTI

ITEM NUMBER: <div style="font-size: 18px; font-weight: bold; text-align: center;">2331564</div>	CHANNEL LIP: <div style="font-size: 18px; font-weight: bold; text-align: center;">SMOOTH</div> <div style="text-align: right; margin-top: 5px;"> </div>
ITEM DESCRIPTION: <div style="font-size: 18px; font-weight: bold; text-align: center;">HAC-V 60 225/550 F</div>	



ITEM	DESCRIPTION	QUANTITY
1	CHANNEL PROFILE	1
2	RIVET CONNECTION	4
3	ROUNDED HEADED ANCHOR	4
4	END CAP	2
5	TEAR OUT BAND	2
6	FILLER FOAM	1

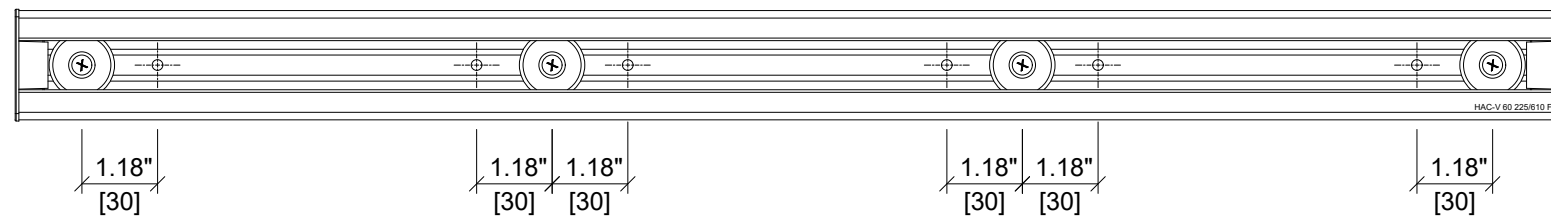
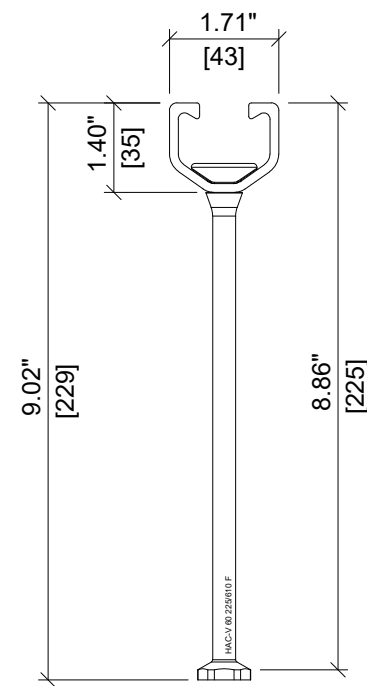
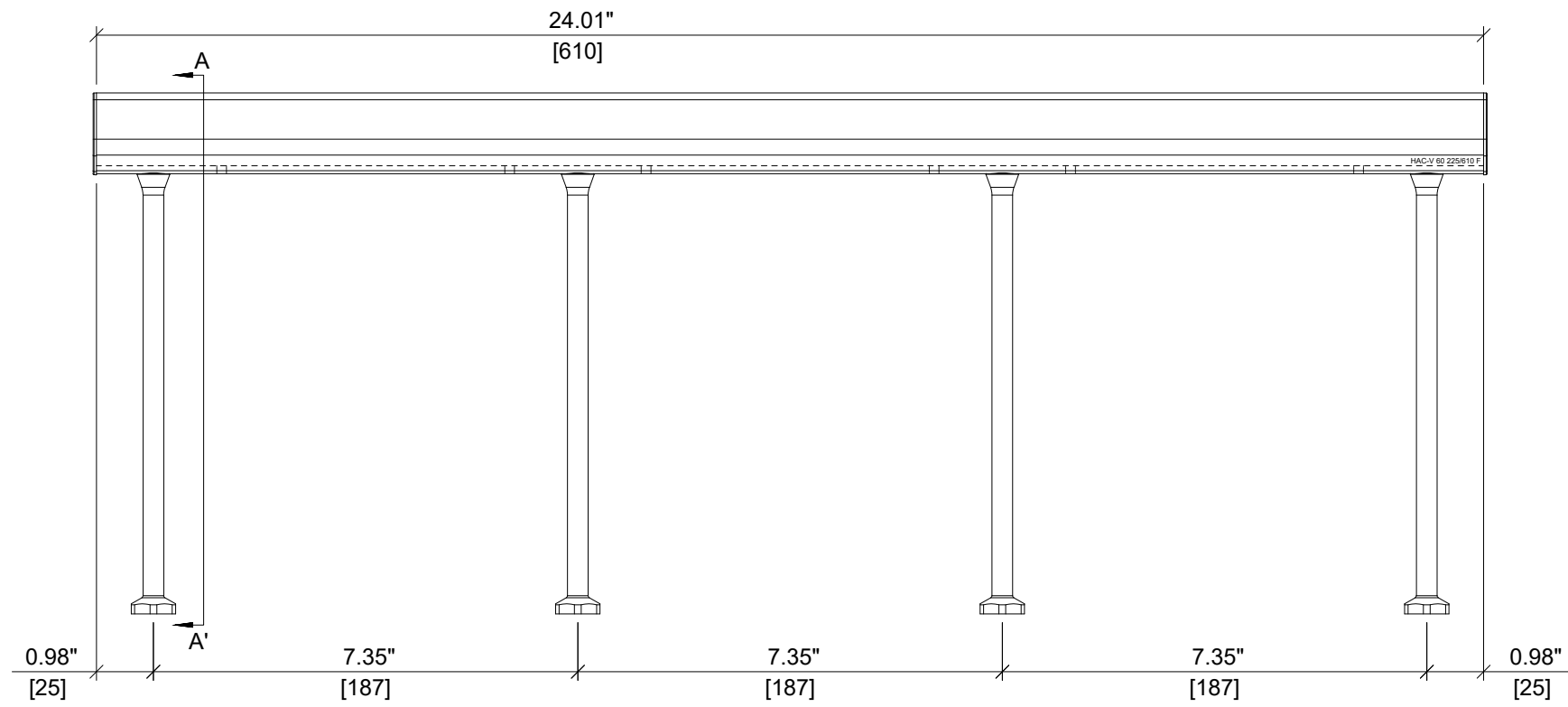

ITEM NUMBER: 2331565	CHANNEL LIP: SMOOTH
--------------------------------	-------------------------------

ITEM DESCRIPTION:
HAC-V 60 225/610 F



ITEM	DESCRIPTION	QUANTITY
1	CHANNEL PROFILE	1
2	RIVET CONNECTION	5
3	ROUNDED HEADED ANCHOR	5
4	END CAP	2
5	TEAR OUT BAND	2
6	FILLER FOAM	1

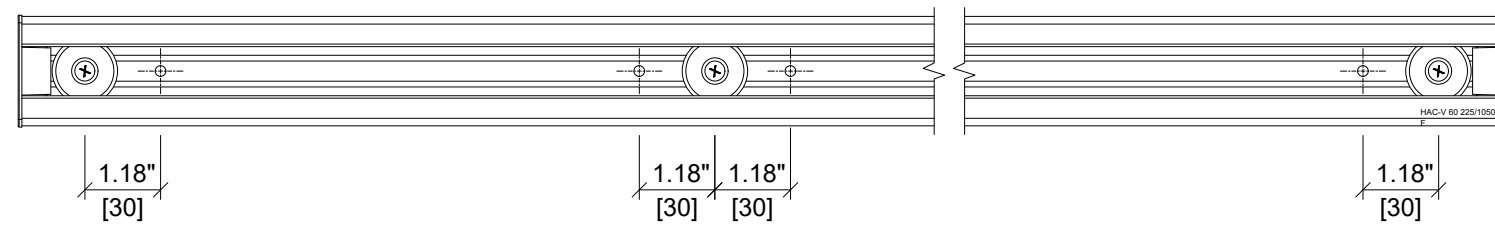
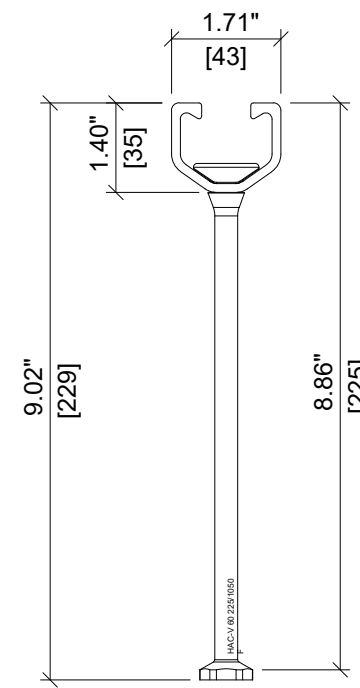
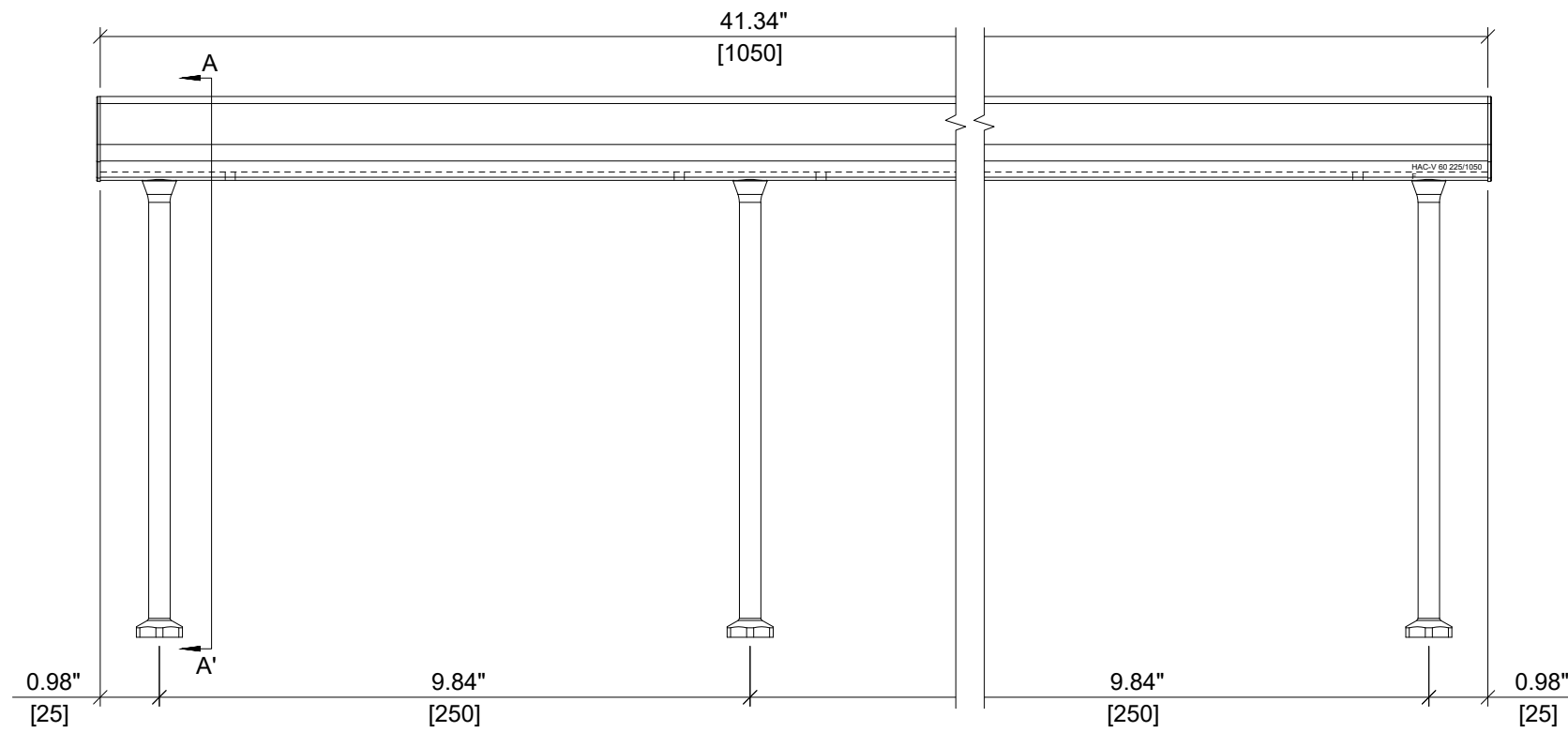

ITEM NUMBER: 2331566	CHANNEL LIP: SMOOTH
--------------------------------	-------------------------------

ITEM DESCRIPTION:
HAC-V 60 225/1050 F



ITEM	DESCRIPTION	QUANTITY
1	CHANNEL PROFILE	1
2	RIVET CONNECTION	24
3	ROUNDED HEADED ANCHOR	24
4	END CAP	2
5	TEAR OUT BAND	2
6	FILLER FOAM	1

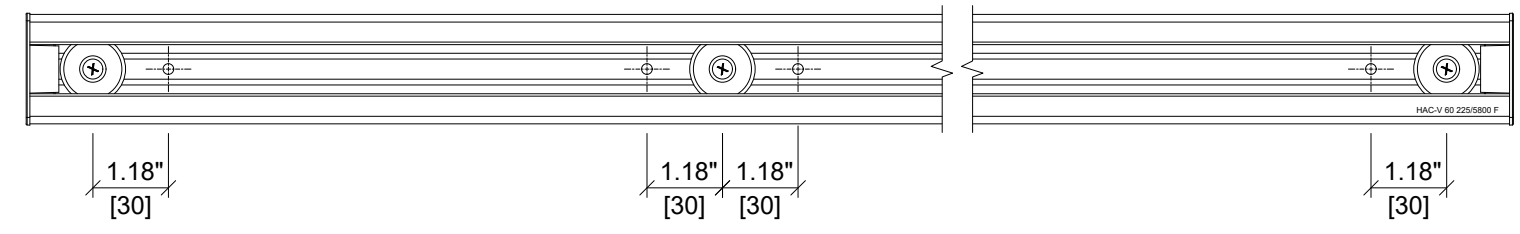
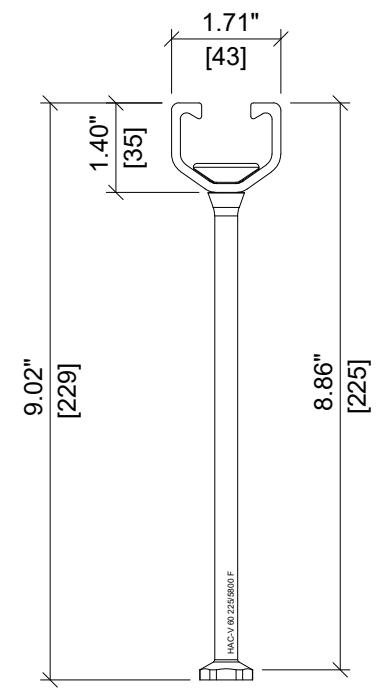
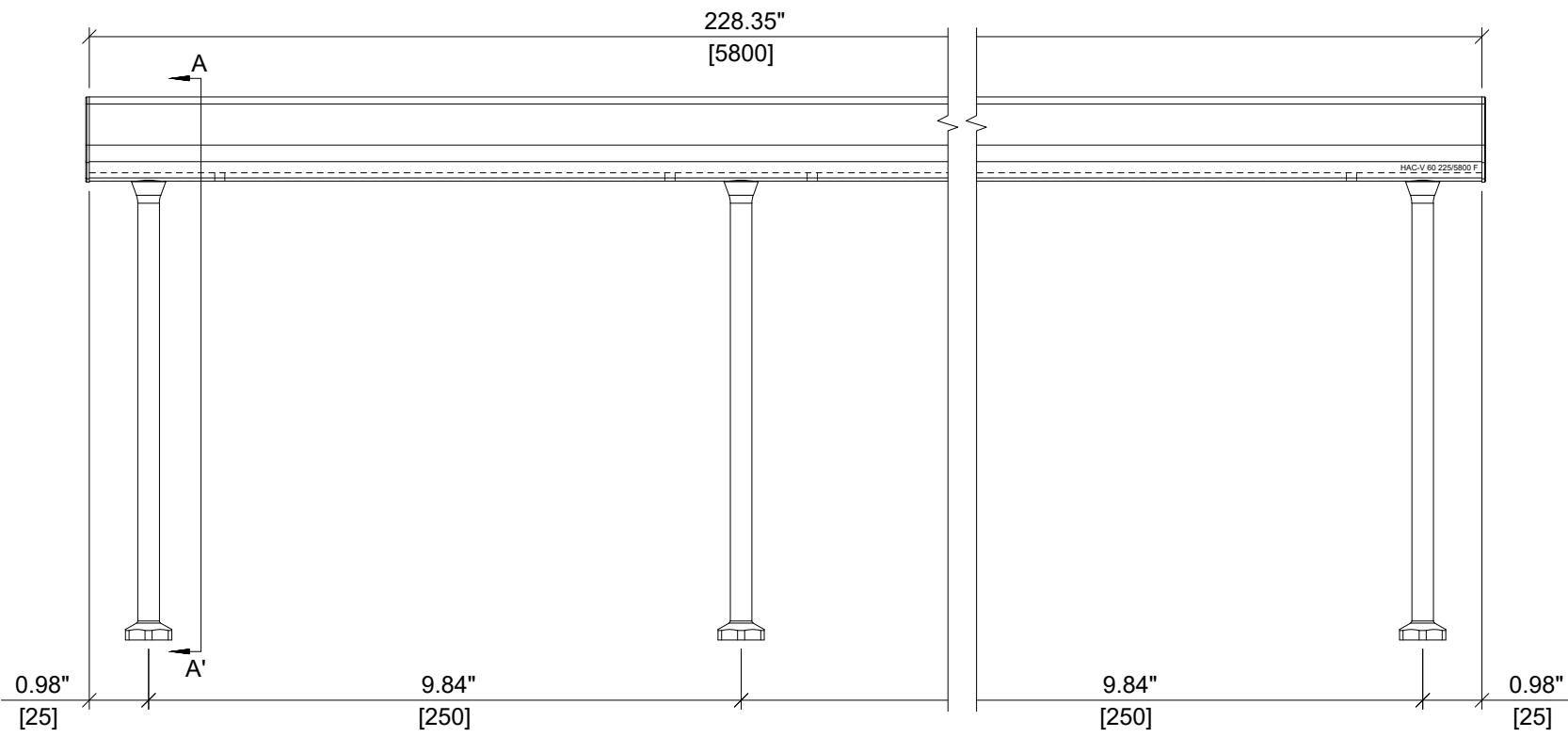

HILTI

ITEM NUMBER: <div style="font-size: 18px; font-weight: bold; text-align: center;">2331567</div>	CHANNEL LIP: <div style="font-size: 18px; font-weight: bold; text-align: center;">SMOOTH</div> <div style="text-align: right; margin-top: 5px;"> </div>
ITEM DESCRIPTION: <div style="font-size: 18px; font-weight: bold; text-align: center;">HAC-V 60 225/5800 F</div>	

