

HVAC LINE SET THROUGH CONCRETE WALL ASSEMBLY

F-RATING = 1-HR. OR 2-HR.

T-RATING = 0-HR., 1/4-HR., OR 1/2-HR. (SEE ITEM 2 BELOW)

L-RATING AT AMBIENT = LESS THAN 1 CFM / SQ FT

L-RATING AT 400°F = LESS THAN 1 CFM / SQ FT

WJ8101a.111522

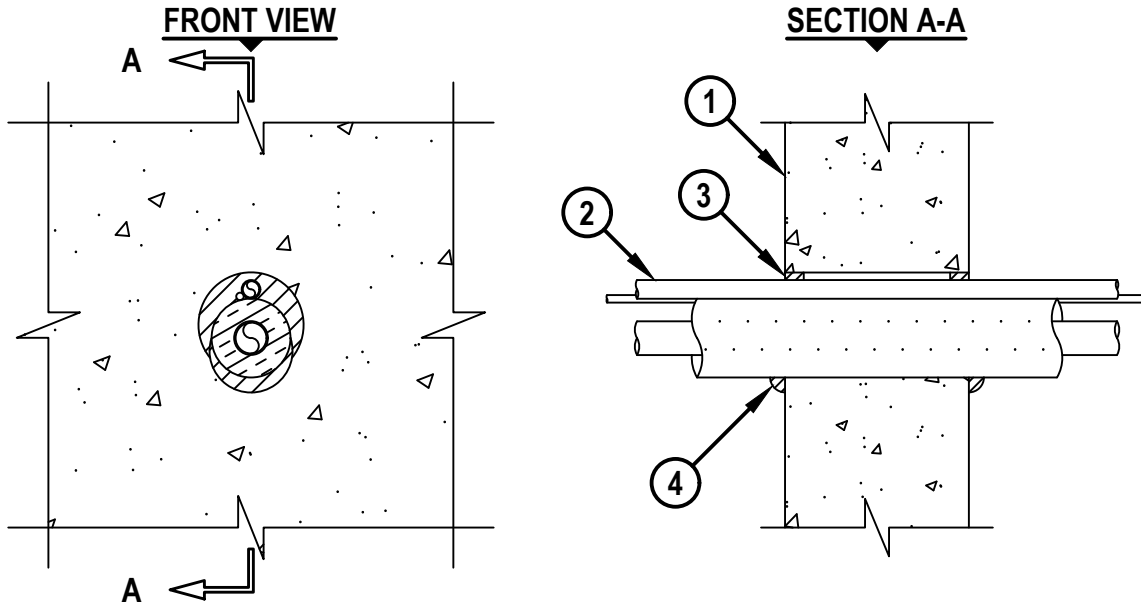

1. LIGHTWEIGHT OR NORMAL WEIGHT CONCRETE WALL OR CONCRETE BLOCK WALL ASSEMBLY.
 - A. MINIMUM 4-7/8" THICK CONCRETE FOR 1-HR. ASSEMBLIES.
 - B. MINIMUM 6-1/8" THICK CONCRETE FOR 2-HR. ASSEMBLIES.
2. HVAC LINE SET CONSISTING OF THE FOLLOWING :
 - A. MAXIMUM 1" NOMINAL DIAMETER COPPER PIPE OR TUBING (MAX. QTY. = 2).
 - B. AB/PVC PIPE INSULATION. ON ONE OF THE METALLIC PIPES OR TUBES, A MAXIMUM 3/4" THICK AB/PVC PIPE INSULATION MAY BE INSTALLED. WHEN AB/PVC PIPE INSULATION IS INSTALLED, THE T-RATING IS 1/4-HR. AND 1/2-HR. FOR 1-HR. AND 2-HR. RATED ASSEMBLIES, RESPECTIVELY.
 - C. EPDM PIPE INSULATION. AS AN ALTERNATIVE TO ITEM 2B, ON ONE METALLIC PIPE OR TUBE, A MAXIMUM 3/4" THICK EPDM PIPE INSULATION MAY BE INSTALLED. WHEN EPDM PIPE INSULATION IS INSTALLED, THE T-RATING IS 0-HR. AND 1/4-HR. FOR 1-HR. AND 2-HR. RATED ASSEMBLIES, RESPECTIVELY.
 - D. MAXIMUM 4 PAIR NO. 18 AWG THERMOSTAT CABLE WITH PVC JACKET.
3. MINIMUM 5/8" DEPTH HILTI FS-ONE MAX INTUMESCENT FIRESTOP SEALANT.
4. MINIMUM 1/2" BEAD HILTI FS-ONE MAX INTUMESCENT FIRESTOP SEALANT APPLIED AT POINT OF CONTACT.

NOTES : 1. MAXIMUM DIAMETER OF OPENING = 3-1/2".
 2. ANNULAR SPACE = MINIMUM 0", MAXIMUM 1/2".

 Hilti Firestop Systems	HILTI, Inc. Plano, Texas USA (800) 879-8000	Sheet 1 of 1	Drawing No. WJ 8101a
		Scale 5/32" = 1"	
		Date Nov. 15, 2022	
Saving Lives through Innovation and Education			