



Classified by
Underwriters Laboratories, Inc.
to UL 1479 and CAN/ULC-S115

System No. C-AJ-8335

CAJ 8335

ANSI/UL1479 (ASTM E814)	CAN/ULC S115
F Ratings – 1 and 2 Hr (See Item 1)	F Ratings – 1 and 2 Hr (See Item 1)
T Rating –1/4 Hr	FT Rating –1/4 Hr
	FH Ratings –1 and 2 Hr (See Item 1)
	FTH Rating –1/4 Hr

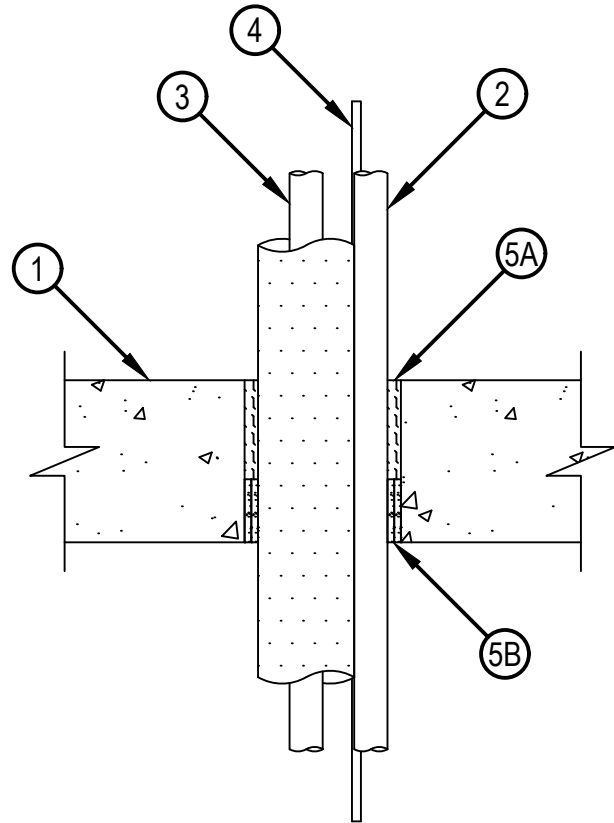
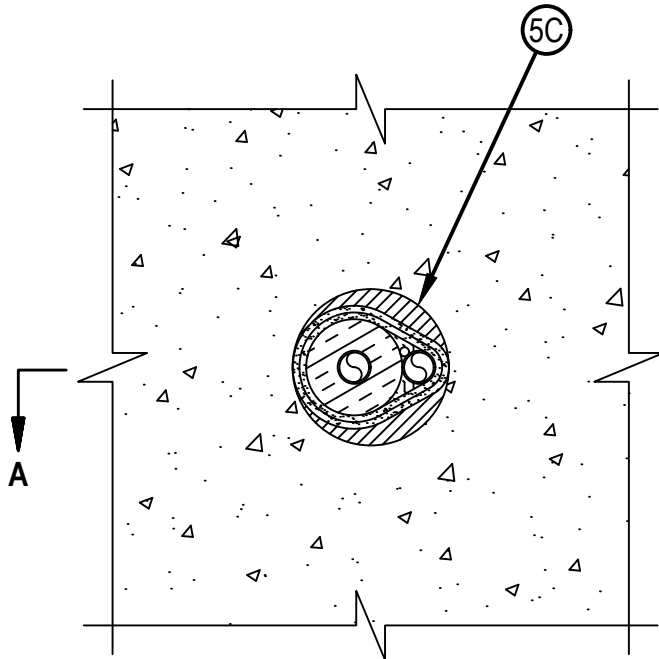

SECTION A-A



Reproduced by HILTI, Inc. Courtesy of
Underwriters Laboratories, Inc.
June 30, 2023

1. Floor or Wall Assembly — Min 4-1/2 in. (114 mm) thick reinforced lightweight or normal weight (100-150 pcf or 1600 - 2400 kg/m³) concrete. Floor assembly may also be constructed of any min 6 in. (152 mm) thick UL Classified hollow-core Precast Concrete Units*. Wall may also be constructed of any UL Classified Concrete Blocks*. Max diam of opening 4 in. (102 mm).
See Concrete Blocks (CAZT) and Precast Concrete Units (CFTV) categories in Fire Resistance Directory for names of manufacturers.
The F Rating of the firestop system is equal to the hourly rating of the floor assembly.
2. Through Penetrants — One pipe, conduit or tube to be installed within the opening. Annular space between the penetrants and the periphery of the opening shall be min 3/8 in. (9.5 mm) to max 1-1/2 in. (38 mm). Penetrants to be rigidly supported on both sides of floor or wall assembly. The following types and sizes of metallic pipe, conduit or tubing may be used:
 - A. Steel Pipe — Nom 3/4 in. (19 mm) diam (or smaller) Schedule 5 (or heavier) steel pipe.
 - B. Iron Pipe — Nom 3/4 in. (19 mm) diam (or smaller) cast or ductile iron pipe.
 - C. Conduit — Nom 3/4 in. (19 mm) diam (or smaller) rigid steel conduit or steel electrical metallic tubing (EMT).
 - D. Copper Pipe — Nom 3/4 in. (19 mm) diam (or smaller) regular (or heavier) copper pipe.
 - E. Copper Tube — Nom 3/4 in. (19 mm) diam (or smaller) Type L (or heavier) copper tube.
3. Insulated Metallic Pipe Assemblies* (BONH Category) — A max of one nom 7/8 in. diam or smaller copper pipe or tube provided with nom 3/4 in. (19 mm) thick (or less) low density polyethylene (LDPE) flexible foam. The annular space between the insulated penetrant and the periphery of the opening shall be min 3/8 in. (9.5) to max 1-1/2 in. (38 mm). Insulated penetrant and non-insulated penetrants to be tightly bundled together.
PDM US LCC - GelCopper and GelBlack PREINSULATED COPPER ROLL
4. Cables — Max one, 4 pair, 18 AWG (or smaller) thermostat cable with PVC insulation jacket. The annular space between the cable and the periphery of the opening shall be min 0 in. (point contact) to max 1-3/8 in. (35 mm). The cable to be tightly bundled together with the other penetrants.
5. Firestop System — The details of the firestop system shall be as follows:
 - A. Packing Material — Min 4 in. (102 mm) thickness of min 4 pcf or 64 kg/m³ mineral wool batt insulation firmly packed into opening as a permanent form. Packing material to be flush with top surface of floor and recessed from bottom surface to accommodate the required thickness of fill material.
 - B. Fill, Void or Cavity Material* — Wrap Strip — Nom 3/16 in. (5 mm) thick by 1-3/4 in. (44 mm) wide intumescent wrap strip continuously wrapped around the through penetrant bundle twice with the ends held in place with masking tape. In floors, bottom edge of wrap strip to be installed flush with bottom surface of concrete. In walls, wrap strip to be installed on both surfaces of wall with visible ends flush with each surface of the wall.
HILTI CONSTRUCTION CHEMICALS, DIV OF HILTI INC — CP 648E Wrap Strip
 - C. Fill, Void or Cavity Materials* - Sealant — Min 1/2 in. (13 mm) thickness of sealant applied within the annulus, flush with bottom surface of floor or with both surfaces of wall. Additional sealant to be applied within interstices of through penetrant bundle and wrap strip to the max extent possible.
HILTI CONSTRUCTION CHEMICALS, DIV OF HILTI INC —FS-ONE MAX Intumescent Sealant

* Indicates such products shall bear the UL or cUL Certification Mark for jurisdictions employing the UL or cUL Certification (such as Canada), respectively.

