

PLAN VIEW

BOLT DESCRIPTION	ITEM NUMBER	BOLT LENGTH, "L" IN. [MM]
HBC-B M12x40 4.6 F	433534	1.57 [40]
HBC-B M12x60 4.6 F	433535	2.36 [60]

NOTE: NUT IS INCLUDED WITH T-BOLT

ITEM	WASHER DESCRIPTION	ITEM NUMBER
A	FLAT WASHER A 13/24-F	304771
B	M12 SPLIT WASHER DIN127 HDG	2150395

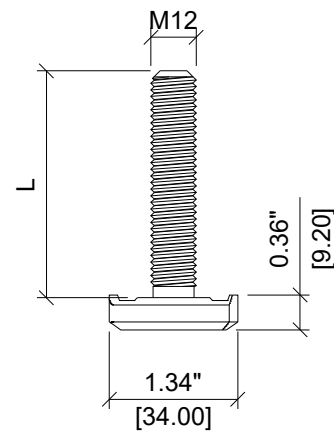

ELEVATION VIEW

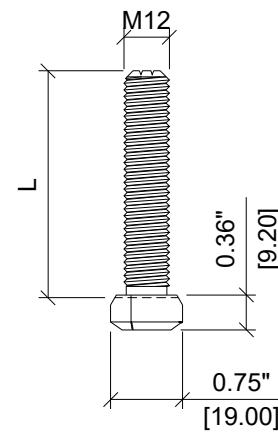

SIDE VIEW

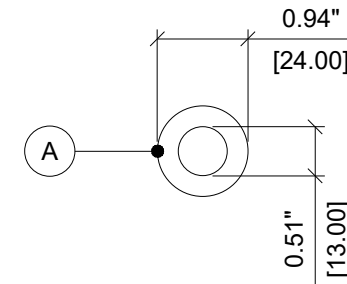

PLAN VIEW

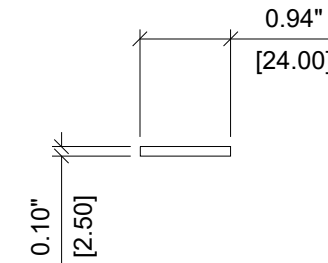

SIDE VIEW

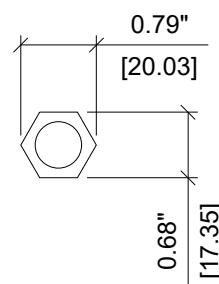

PLAN VIEW

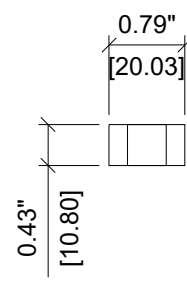

SIDE VIEW

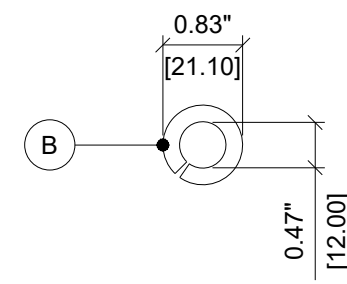

PLAN VIEW

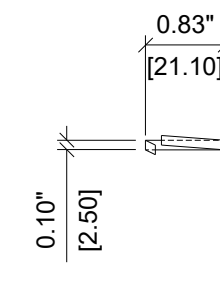

SIDE VIEW

Note:
T-BOLTS AND HARDWARE ARE METRIC SIZES. DIMENSIONS ARE CONVERTED TO IMPERIAL UNITS TO THE NEAREST TWO DECIMAL PLACES.

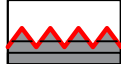

ITEM NUMBER: VARIES	CHANNEL LIP: SERRATED 
ITEM DESCRIPTION: HBC-B M12-T-BOLT, NUT & WASHERS	



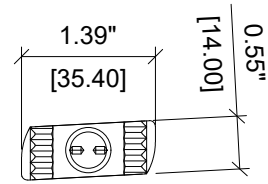

PLAN VIEW

BOLT DESCRIPTION	ITEM NUMBER	BOLT LENGTH, "L" IN. [MM]
HBC-T M12x40 8.8F	2152672	1.57 [40]
HBC-T M12x60 8.8F	2152673	2.36 [60]
HBC-T M12x80 8.8F	2152674	3.15 [80]

NOTE: NUT IS INCLUDED WITH T-BOLT

ITEM	WASHER DESCRIPTION	ITEM NUMBER
A	FLAT WASHER A 13/24-F	304771
B	M12 SPLIT WASHER DIN127 HDG	2150395

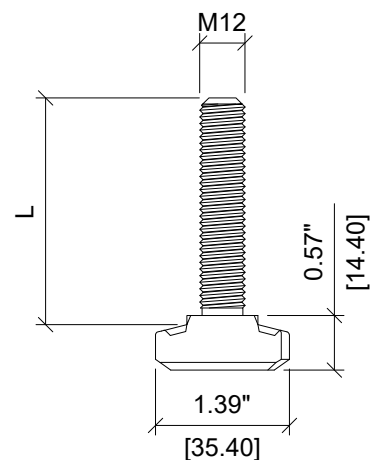

ELEVATION VIEW

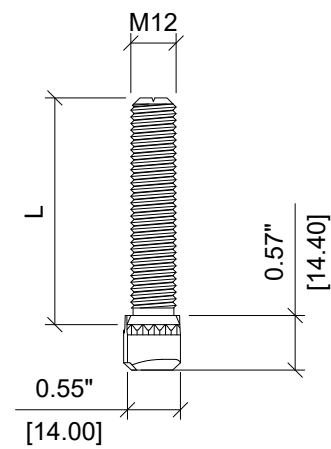

SIDE VIEW

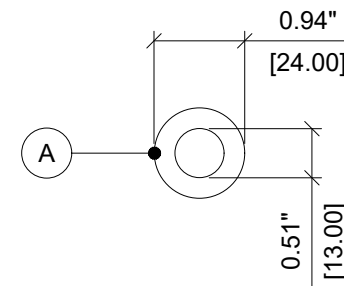

PLAN VIEW

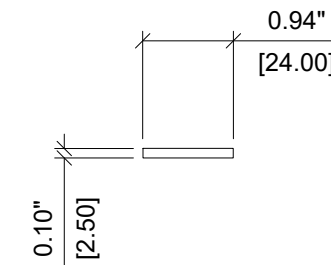

SIDE VIEW

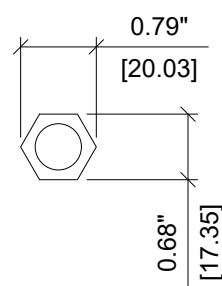

PLAN VIEW

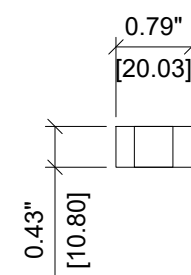

SIDE VIEW

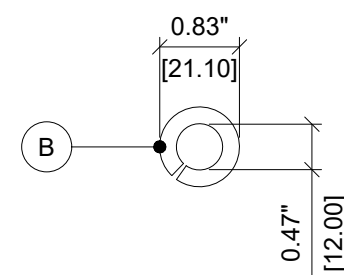

PLAN VIEW

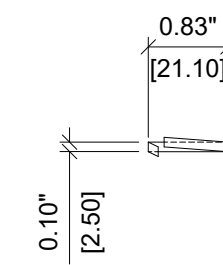

SIDE VIEW

Note:
T-BOLTS AND HARDWARE ARE METRIC SIZES. DIMENSIONS ARE CONVERTED TO IMPERIAL UNITS TO THE NEAREST TWO DECIMAL PLACES.

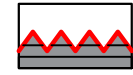

ITEM NUMBER: VARIES	CHANNEL LIP: SERRATED 
-------------------------------	---

ITEM DESCRIPTION:
HBC-T M12-T-BOLT, NUT & WASHERS



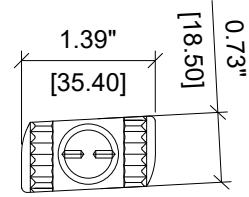

PLAN VIEW

BOLT DESCRIPTION	ITEM NUMBER	BOLT LENGTH, "L" IN. [MM]
HBC-T M16x60 8.8F	2152675	2.36 [60]
HBC-T M16x80 8.8F	2152676	3.15 [80]
HBC-T M16x100 8.8F	2152677	3.94 [100]

NOTE: NUT IS INCLUDED WITH T-BOLT

ITEM	WASHER DESCRIPTION	ITEM NUMBER
A	FLAT WASHER A 17/30-F	304772
B	M16 SPLIT WASHER DIN127 HDG	2150396

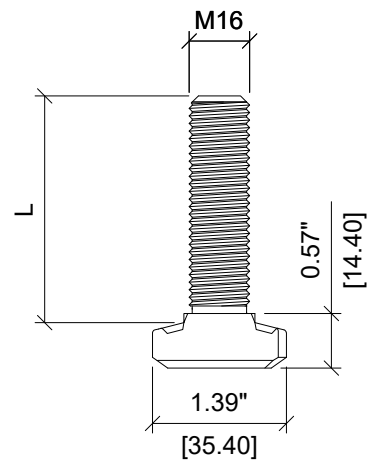

ELEVATION VIEW

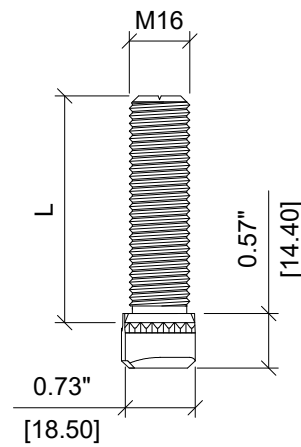

SIDE VIEW

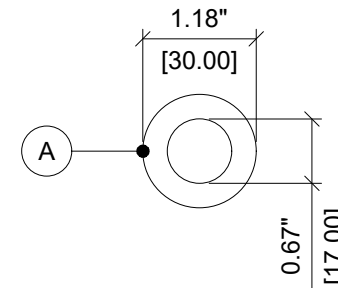

PLAN VIEW

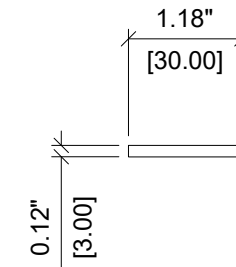

SIDE VIEW

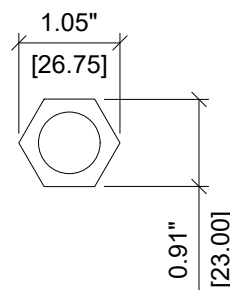

PLAN VIEW

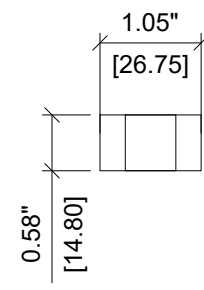

SIDE VIEW

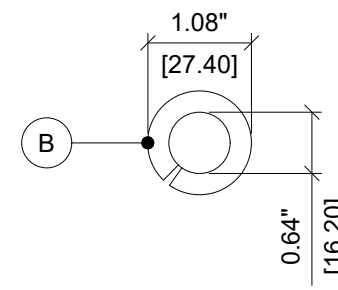

PLAN VIEW

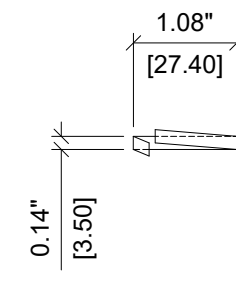

SIDE VIEW

Note:
T-BOLTS AND HARDWARE ARE METRIC SIZES. DIMENSIONS ARE CONVERTED TO IMPERIAL UNITS TO THE NEAREST TWO DECIMAL PLACES.

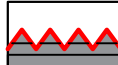

ITEM NUMBER: VARIES	CHANNEL LIP: SERRATED 
-------------------------------	---

ITEM DESCRIPTION:
HBC-T M16-T-BOLT, NUT & WASHERS



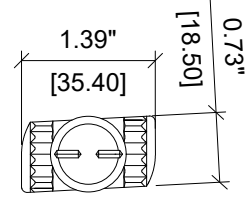

PLAN VIEW

BOLT DESCRIPTION	ITEM NUMBER	BOLT LENGTH, "L" IN. [MM]
HBC-T M20x60 8.8F	2152678	2.36 [60]
HBC-T M20x80 8.8F	2152679	3.15 [80]
HBC-T M20x100 8.8F	2152710	3.94 [100]

NOTE: NUT IS INCLUDED WITH T-BOLT

WASHER DESCRIPTION	ITEM NUMBER
FLAT WASHER A 21/37-F	2008399

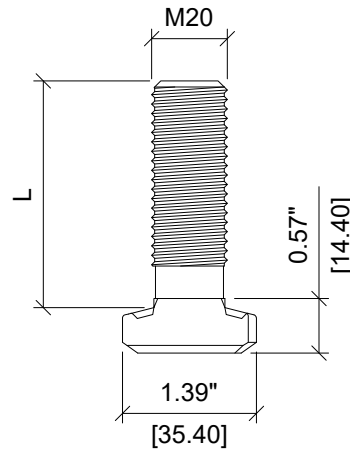

ELEVATION VIEW

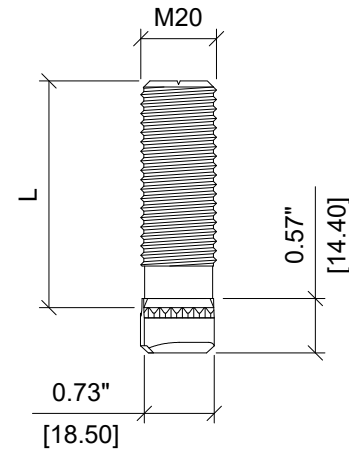

SIDE VIEW

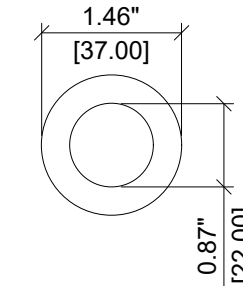

PLAN VIEW

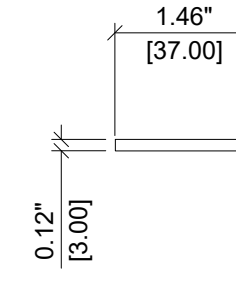

SIDE VIEW

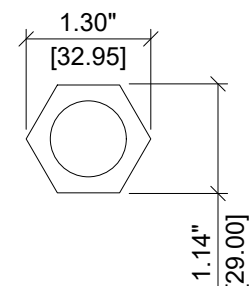

PLAN VIEW

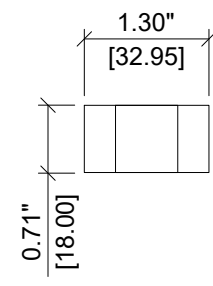

SIDE VIEW

Note:
T-BOLTS AND HARDWARE ARE METRIC SIZES. DIMENSIONS ARE CONVERTED TO IMPERIAL UNITS TO THE NEAREST TWO DECIMAL PLACES.

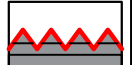

ITEM NUMBER: VARIES	CHANNEL LIP: SERRATED 
-------------------------------	---

ITEM DESCRIPTION:
HBC-T M20-T-BOLT, NUT & WASHERS

