

UL SYSTEM NO. F-G-2003  
**PLASTIC PIPE THROUGH MASS TIMBER FLOOR ASSEMBLY**

F-RATING = 2-HR.  
T-RATING = 1-1/2-HR.

FG2003a.111123

**BOTTOM VIEW**

**SECTION A-A**

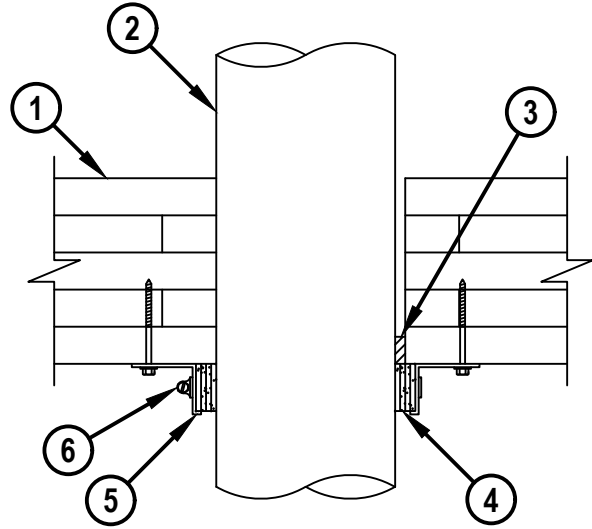
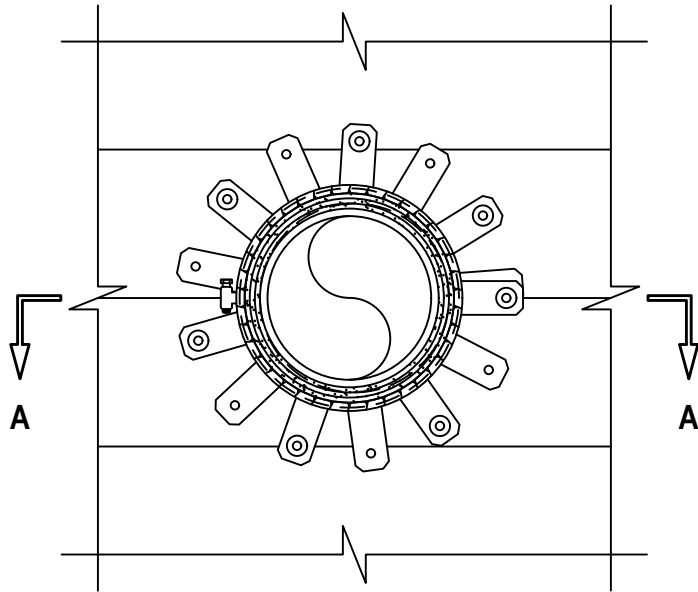

HILTI, Inc.  
Plano, Texas USA (800) 879-8000

Sheet	1 of 2
Scale	9/64" = 1"
Date	Nov. 17, 2023

Drawing No.  
**FG  
2003a**

*Saving Lives through Innovation and Education*

UL SYSTEM NO. F-G-2003  
**PLASTIC PIPE THROUGH MASS TIMBER FLOOR ASSEMBLY**

F-RATING = 2-HR.  
T-RATING = 1-1/2-HR.

FG2003a.111123

1. CROSS-LAMINATED TIMBER (CLT) PANEL, MINIMUM 6-7/8", 5 PLY CROSS-LAMINATED TIMBER (CLT) LABELED GRADE E1 IN ACCORDANCE WITH ANSI/APA PRG 320 AS REQUIRED BY CHAPTER 6 OF INTERNATIONAL BUILDING CODE (IBC) FOR TYPE IVA, IVB, OR IVC CONSTRUCTION. THE REQUIRED HOURLY RATING OF THE CLT FLOOR SHALL BE DETERMINED IN ACCORDANCE WITH CHAPTER 16 OF THE NATIONAL DESIGN SPECIFICATION (NDS). ADDITIONAL INFORMATION REGARDING THE USE OF CLT AS PERMITTED IN THE IBC IS LOCATED IN THE UL XHEZ GUIDE INFORMATION.
2. PENETRATING ITEM TO BE ONE OF THE FOLLOWING :
  - A. MAXIMUM 6" NOMINAL DIAMETER PVC PLASTIC PIPE (SCHEDULE 40) (CLOSED OR VENTED PIPING SYSTEM).
  - B. MAXIMUM 6" NOMINAL DIAMETER CPVC PLASTIC PIPE (SDR 11 OR SDR 13.5) (CLOSED PIPING SYSTEM ONLY).
3. MINIMUM 1" DEPTH HILTI FS-ONE MAX INTUMESCENT FIRESTOP SEALANT.
4. HILTI CP 648E WRAP STRIP (NOMINAL 3/16" THICK x 1-3/4" WIDE) CONTINUOUSLY WRAPPED AROUND THE OUTER CIRCUMFERENCE OF THE PIPE, WITH ENDS BUTTED AND HELD IN PLACE WITH (MASKING OR ALUMINUM) TAPE. SEE TABLE BELOW FOR THE REQUIRED NUMBER OF WRAP STRIP LAYERS.

PENETRANT	MAX NOM DIAM OF PENETRANT, IN.	NUMBER OF LAYERS OF WRAP STRIP
2A, 2B	2	2
2A, 2B	6	4

5. HILTI 1-3/4" (44 MM) RETAINING COLLAR WRAPPED OVER WRAP STRIPS, OVERLAPPING MINIMUM 2" (52 MM). ATTACH EVERY OTHER TAB TO BOTTOM OF FLOOR WITH 3" LONG WOOD SCREWS AND 3/4" (19 MM) DIAMETER STEEL WASHERS.
6. SECURE COLLAR TOGETHER AT OVERLAP LOCATION WITH NOMINAL 1/2" (13 MM) STEEL HOSE CLAMP.

NOTES : 1. MAXIMUM DIAMETER OF OPENING = 7".  
2. ANNULAR SPACE = MINIMUM 0", MAXIMUM 1/2".

 <b>Hilti Firestop Systems</b>	HILTI, Inc. Plano, Texas USA (800) 879-8000	<i>Sheet</i> 2 of 2	<i>Drawing No.</i> <b>FG 2003a</b>
		<i>Scale</i> -	
		<i>Date</i> Nov. 17, 2023	