

**PLASTIC PIPE THROUGH CONCRETE FLOOR/WALL OR BLOCK WALL ASSEMBLY**

F-RATING = 2-HR.

T-RATING = 1-3/4-HR. OR 2-HR.

CAJ2435e.010515

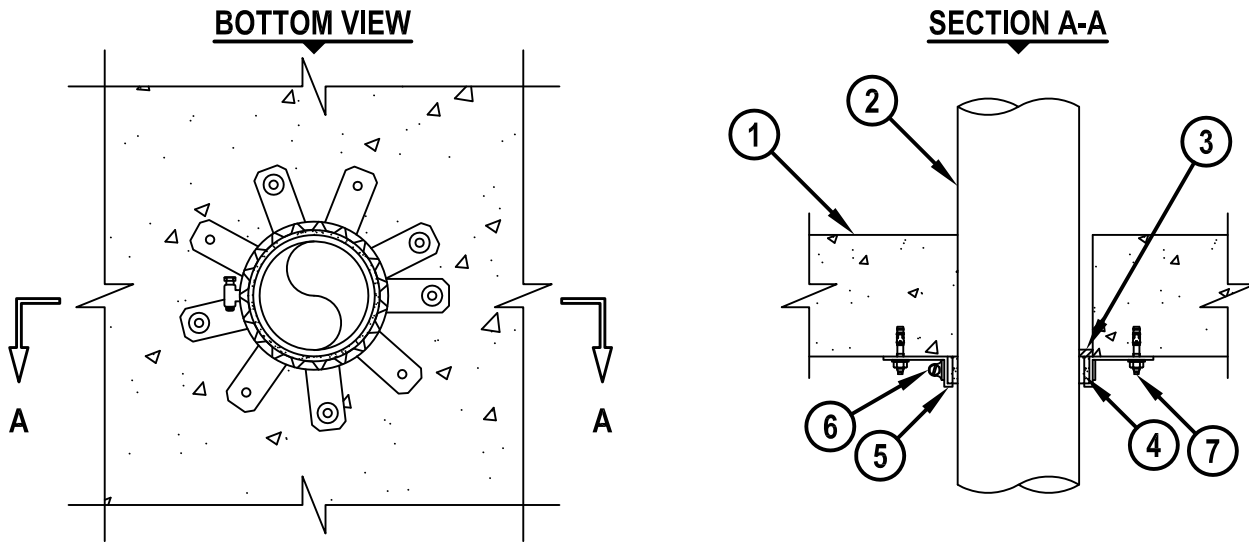

1. CONCRETE FLOOR OR WALL ASSEMBLY (2-HR. FIRE-RATING) :
  - A. LIGHTWEIGHT OR NORMAL WEIGHT CONCRETE FLOOR OR WALL (MINIMUM 4-1/2" THICK).
  - B. ANY UL CLASSIFIED CONCRETE BLOCK WALL.
2. PENETRATING ITEM TO BE ONE OF THE FOLLOWING :
  - A. MAXIMUM 4" NOMINAL DIAMETER PVC PLASTIC PIPE (CELLULAR OR SOLID CORE).
  - B. MAXIMUM 4" NOMINAL DIAMETER ABS PLASTIC PIPE (CELLULAR OR SOLID CORE).
  - C. MAXIMUM 4" NOMINAL DIAMETER CPVC PLASTIC PIPE (CLOSED PIPING SYSTEM ONLY).
3. MINIMUM 1/4" DEPTH HILTI FS-ONE MAX OR FS-ONE INTUMESCENT FIRESTOP SEALANT FLUSH WITH BOTTOM SURFACE OF FLOOR.
4. HILTI CP 648E WRAP STRIP (NOMINAL 3/16" THICK x 1" WIDE) CONTINUOUSLY WRAPPED AROUND THE OUTER CIRCUMFERENCE OF PIPE, COVERING TWO TIMES, WITH ENDS BUTTED AND HELD IN PLACE WITH TAPE. WRAP STRIP TO BE BUTTED TIGHTLY AGAINST BOTTOM SURFACE OF FLOOR.
5. HILTI 1" RETAINING COLLAR WRAPPED OVER WRAP STRIPS, OVERLAPPING MINIMUM 1".
6. NOMINAL 1/2" WIDE STAINLESS STEEL HOSE CLAMP(S) FASTENED AT MID-HEIGHT OF RETAINING COLLAR(S) OR SECURE WITH TWO NO. 8 SHEET METAL SCREWS THROUGH THE OVERLAP OF COLLAR.
7. EVERY OTHER TAB OR MINIMUM 3 SYMMETRICALLY SPACED TABS OF RETAINING COLLAR SECURED TO BOTTOM OF FLOOR WITH 1/4" x 1-3/4" LONG STEEL EXPANSION BOLTS, 1/4" x 1-1/4" LONG CONCRETE SCREW ANCHORS, MIN. 0.145" x 1-1/4" POWDER ACTUATED FASTENERS WITH 1-7/16" DIAMETER STEEL WASHER, 1/4" x 1-1/4" HILTI KWIK-CON II+ CONCRETE SCREW ANCHOR, 1/4" x 1-3/4" HILTI KWIK-BOLT 3 STEEL EXPANSION ANCHOR, OR HILTI X-DNI 27 P8 S15 POWDER ACTUATED FASTENER WITH INTEGRATED WASHER.

NOTES : 1. MAXIMUM DIAMETER OF OPENING = 5".  
 2. ANNULAR SPACE = MINIMUM 0", MAXIMUM 1/2".  
 3. CLOSED OR VENTED PIPING SYSTEM (PVC, ABS = SCHEDULE 40; CPVC = SDR 13.5).



HILTI, Inc.  
 Tulsa, Oklahoma USA (800) 879-8000

Sheet	1 of 1
Scale	9/64" = 1"
Date	Jan. 05, 2015

Drawing No.  
**CAJ  
 2435e**