

METAL PIPE THROUGH HOLLOW-CORE CONCRETE FLOOR ASSEMBLY

F-RATING = 2-HR.
T-RATING = 1/4-HR.

CBJ1046b.010615

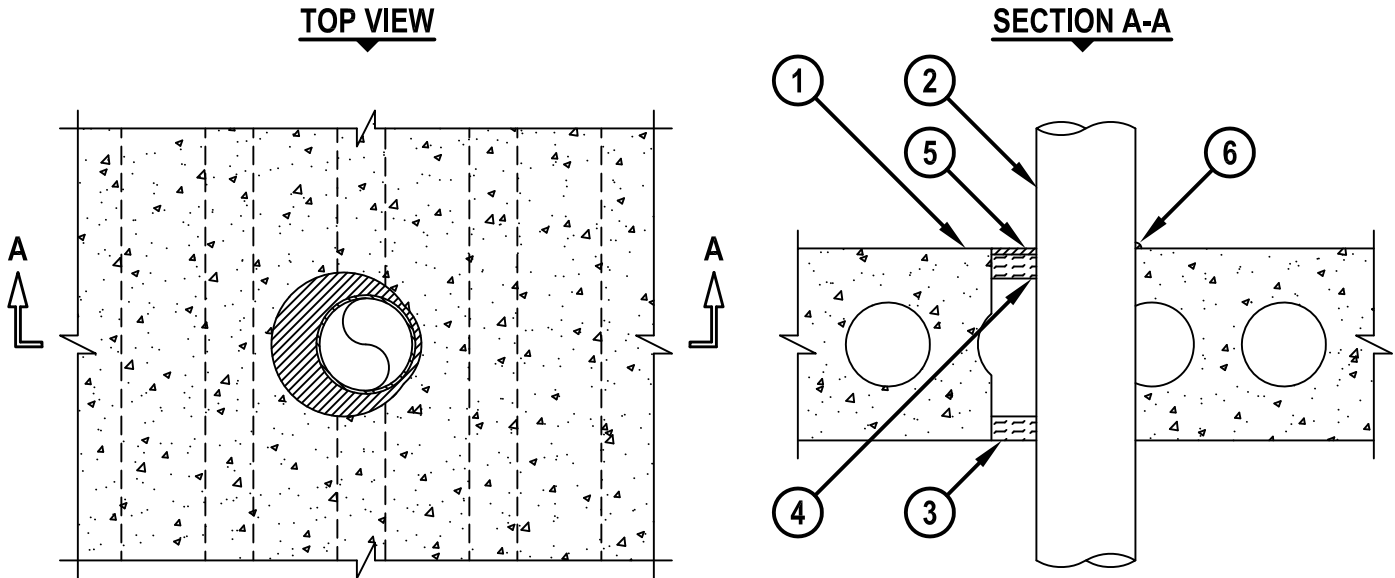

1. ANY UL/cUL CLASSIFIED PRE-CAST HOLLOW CORE CONCRETE FLOOR ASSEMBLY (MINIMUM 8" THICK) (2-HR. FIRE-RATING).
2. PENETRATING ITEM TO BE ONE OF THE FOLLOWING :
 - A. MAXIMUM 4" NOMINAL DIAMETER STEEL PIPE (SCHEDULE 10 OR HEAVIER).
 - B. MAXIMUM 4" NOMINAL DIAMETER CAST IRON PIPE.
 - C. MAXIMUM 4" NOMINAL DIAMETER COPPER PIPE.
 - D. MAXIMUM 4" NOMINAL DIAMETER STEEL CONDUIT.
 - E. MAXIMUM 4" NOMINAL DIAMETER EMT.
3. MINIMUM 1" THICKNESS MINERAL WOOL (MIN. 4 PCF DENSITY) TIGHTLY PACKED AND INSTALLED FLUSH WITH THE BOTTOM SURFACE OF THE FLOOR.
4. MINIMUM 1" THICKNESS MINERAL WOOL (MIN. 4 PCF DENSITY) TIGHTLY PACKED AND RECESSED FROM THE TOP SURFACE OF THE ASSEMBLY TO ACCOMMODATE FIRESTOP SEALANT.
5. MINIMUM 1/4" DEPTH HILTI FS-ONE MAX OR FS-ONE INTUMESCENT FIRESTOP SEALANT.
6. MINIMUM 1/4" BEAD HILTI FS-ONE MAX OR FS-ONE INTUMESCENT FIRESTOP SEALANT APPLIED AT POINT OF CONTACT.

NOTES : 1. MAXIMUM DIAMETER OF OPENING = 6".
2. ANNULAR SPACE = MINIMUM 0", MAXIMUM 1-7/8".



HILTI, Inc.
Tulsa, Oklahoma USA (800) 879-8000

Sheet	1 of 1
Scale	1/8" = 1"
Date	Jan. 06, 2015

Drawing No.
**CBJ
1046b**