

**METAL PIPE THROUGH CONCRETE FLOOR OR CONCRETE OVER METAL DECKING**

F-RATING = 3-HR.

T-RATING = 0-HR.

L-RATING AT AMBIENT = 1 CFM / SQ FT

L-RATING AT 400°F = LESS THAN 1 CFM / SQ FT

W-RATING = CLASS I (SEE NOTES NO. 3 AND 4 BELOW)

FA1017n.071815

**TOP VIEW**

**SECTION A-A**

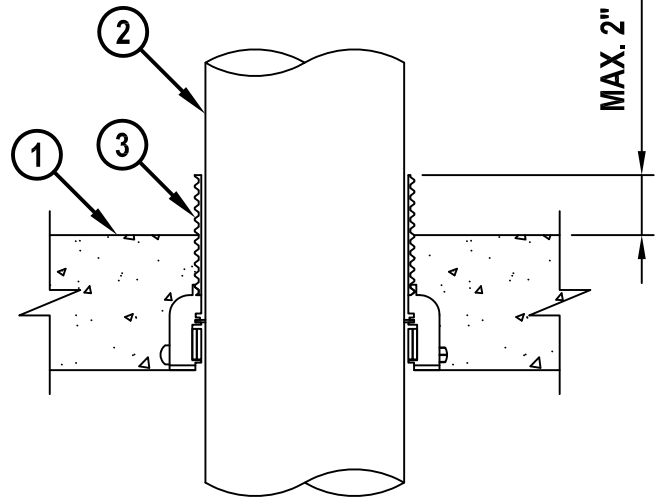
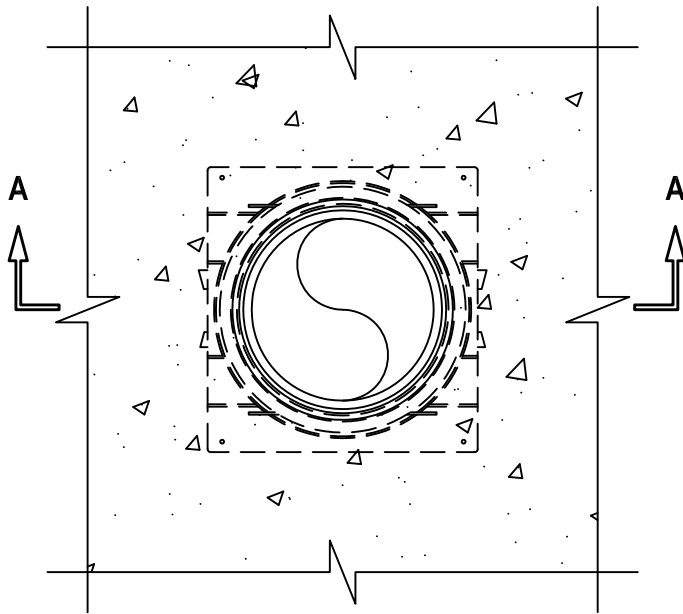

**1. CONCRETE FLOOR ASSEMBLY (3-HR. FIRE-RATING) :**

**A. LIGHTWEIGHT OR NORMAL WEIGHT CONCRETE FLOOR (MINIMUM 4-1/2" THICK).**

**B. STEEL FLOOR UNIT/FLOOR ASSEMBLY - LIGHTWEIGHT OR NORMAL WEIGHT CONCRETE FLOOR (MINIMUM 4-1/2" THICK) OVER METAL DECKING.**

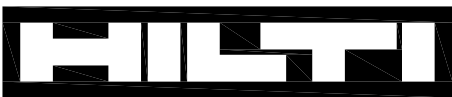

**Hilti Firestop Systems**

HILTI, Inc.  
Plano, Texas USA (800) 879-8000

Sheet 1 of 2

Scale 5/32" = 1"

Date July 18, 2015

Drawing No.

**FA  
1017n**

**METAL PIPE THROUGH CONCRETE FLOOR OR CONCRETE OVER METAL DECKING**

F-RATING = 3-HR.

T-RATING = 0-HR.

L-RATING AT AMBIENT = 1 CFM / SQ FT

L-RATING AT 400°F = LESS THAN 1 CFM / SQ FT

W-RATING = CLASS I (SEE NOTES NO. 3 AND 4 BELOW)

FA1017n.071815

2. PENETRATING ITEM TO BE ONE OF THE FOLLOWING :
  - A. MAXIMUM 6" NOMINAL DIAMETER STEEL PIPE (SCHEDULE 10 OR HEAVIER).
  - B. MAXIMUM 6" NOMINAL DIAMETER CAST OR DUCTILE IRON PIPE.
  - C. MAXIMUM 6" NOMINAL DIAMETER COPPER PIPE OR TUBING.
  - D. MAXIMUM 6" NOMINAL DIAMETER STEEL CONDUIT.
  - E. MAXIMUM 4" NOMINAL DIAMETER EMT.
3. HILTI CP 680-M, CP 680-P, OR CP 680-PX CAST-IN FIRESTOP DEVICE CAST OR GROUTED INTO CONCRETE FLOOR (SEE TABLE BELOW).

NOMINAL PIPE DIAMETER	PENETRANT TYPE	PRODUCT DESCRIPTION
1-1/2" TO 2"	ALL	CP 680-M 2", CP 680-P 2", OR CP 680-PX 2"
2-1/2" TO 3"	ALL	CP 680-M 3", CP 680-P 3", OR CP 680-PX 3"
3" TO 4"	COPPER	CP 680-P 4"
3" TO 4"	STEEL, CAST IRON, CONDUIT, EMT	CP 680-M 4" OR CP 680-P 4"
4"	COPPER	CP 680-M 4"
6"	ALL	CP 680-M 6" OR CP 680-P 6"

**NOTES :**

1. FOR CONCRETE FLOOR OVER METAL DECKING APPLICATIONS, A METAL DECK ADAPTER KIT IS REQUIRED.
2. WHEN PIPE DIAMETER IS SMALLER THAN INDICATED ABOVE, A MINIMUM 1" THICKNESS HILTI CP 618 FIRESTOP PUTTY STICK OR MINIMUM 4" THICKNESS TIGHTLY PACKED MINERAL WOOL (MIN. 4 PCF DENSITY) SHALL BE APPLIED WITHIN THE ANNULUS BETWEEN THE PIPE AND PERIPHERY OF CAST-IN FIRESTOP DEVICE, FLUSH WITH WITH TOP SURFACE OF DEVICE.
3. AS AN ALTERNATE TO ITEMS ABOVE (NOTE 2) HILTI IPS OR CPS TOP SEAL MAY BE USED ON 1/2" TO 2" NOMINAL DIAMETER PIPES IN CONJUNCTION WITH HILTI 2" CAST-IN FIRESTOP DEVICES. W-RATING APPLIES ONLY TO 1", 1-1/4", 1-1/2", AND 2" COPPER PIPE/TUBES IN CONJUNCTION WITH CORRESPONDING CPS TOP SEAL PLUG.
4. WATER BARRIER MODULES MAY BE THREADED ON TOP OF CAST-IN FIRESTOP DEVICES FOR NOMINAL 2", 3", 4", AND 6" METAL PIPES (LISTED ABOVE). IN ADDITION, A 3" WATER BARRIER MODULE MAY BE USED ON A NOMINAL 2-1/2" STEEL, CAST IRON, STEEL CONDUIT, OR EMT IN CONJUNCTION WITH A CP 680-M 3", CP 680-P 3" OR CP 680-PX 3". W-RATING WITH WATER BARRIER MODULE ONLY APPLIES WHEN DIAMETER OF PIPE EQUALS SIZE OF MODULE AND WHEN PIPE IS INSTALLED FROM BOTTOM OF DEVICE.
5. L-RATING APPLIES ONLY WHEN NOMINAL DIAMETER OF PIPE EQUALS SIZE OF DEVICE (2" PIPE IN 2" DEVICE, ETC.).



HILTI, Inc.  
Plano, Texas USA (800) 879-8000

Sheet	2 of 2
Scale	-
Date	July 18, 2015

Drawing No.  
**FA  
1017n**