

TOP OF WALL JOINT : CONCRETE WALL OR BLOCK WALL ASSEMBLY

ASSEMBLY RATING = 2-HR.

CLASS II MOVEMENT CAPABILITIES - 12.5% COMPRESSION OR EXTENSION

L-RATING AT AMBIENT = LESS THAN 1 CFM/LIN FT

L-RATING AT 400°F = LESS THAN 1 CFM/LIN FT

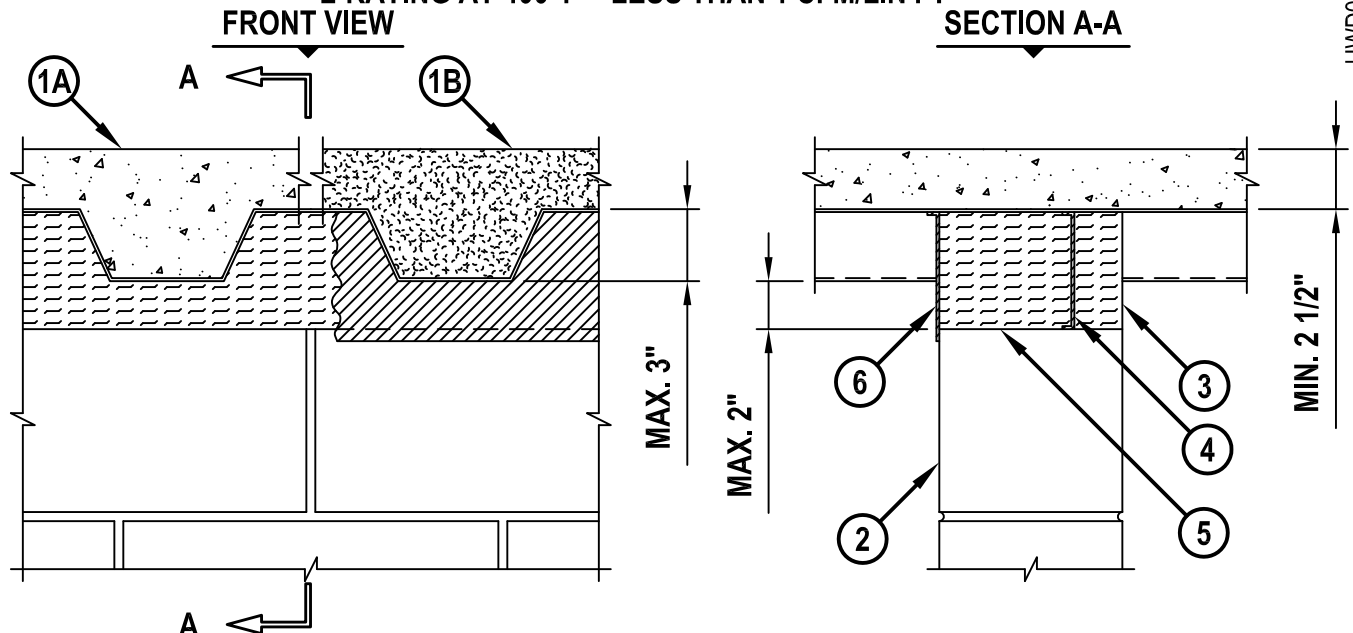

HWD0285e.052510

1. FLOOR OR ROOF ASSEMBLY (2-HR. FIRE-RATING) :
 - A. LIGHTWEIGHT OR NORMAL WEIGHT CONCRETE FLOOR (MIN. 2-1/2" THICK) OVER METAL DECKING (UL/cUL CLASSIFIED D900 SERIES).
 - B. INSULATING CONCRETE (MIN. 2-1/4" THICK) OVER METAL DECKING (UL/cUL CLASSIFIED P900 SERIES).
2. CONCRETE WALL ASSEMBLY (2-HR. FIRE-RATING) :
 - A. LIGHTWEIGHT OR NORMAL WEIGHT CONCRETE WALL (MINIMUM 8" THICK).
 - B. ANY UL/cUL CLASSIFIED CONCRETE BLOCK WALL.
3. MINIMUM 2" THICKNESS MINERAL WOOL (MIN. 4 PCF DENSITY) COMPRESSED 33% TO FILL THE JOINT AND FLUTE ON ONE SIDE OF THE WALL.
4. MINIMUM 1/8" (WET) THICKNESS HILTI CFS-SP WB FIRESTOP JOINT SPRAY OR HILTI CP 672 SPEED SPRAY TO COMPLETELY COVER MINERAL WOOL AND TO OVERLAP MINIMUM 1/2" ONTO CONCRETE WALL OR CONCRETE BLOCK WALL AND METAL DECK.
5. MINIMUM 6" THICKNESS MINERAL WOOL (MIN. 4 PCF DENSITY) COMPRESSED 33% AND FLUSH WITH WALL ASSEMBLY.
6. MINIMUM 1/8" (WET) THICKNESS HILTI CFS-SP WB FIRESTOP JOINT SPRAY OR HILTI CP 672 SPEED SPRAY TO COMPLETELY COVER MINERAL WOOL AND TO OVERLAP MINIMUM 1/2" ONTO CONCRETE WALL OR CONCRETE BLOCK WALL AND METAL DECK.

NOTES : 1. MAXIMUM WIDTH OF JOINT = 2".
 2. AS AN ALTERNATE TO THE MINERAL WOOL INSTALLED IN THE FLUTES, HILTI CP 777 SPEED PLUGS MAY BE USED.
 3. THIS FIRESTOP SYSTEM WAS DESIGNED AND TESTED FOR APPLICATIONS IN WHICH THERE IS LIMITED OR NO ACCESS AVAILABLE ON ONE SIDE OF THE WALL.



HILTI, Inc.
 Tulsa, Oklahoma USA (800) 879-8000

Sheet	1 of 1
Scale	1/8" = 1"
Date	May 25, 2010

Drawing No.
**HWD
 0285e**