

UL/cUL SYSTEM NO. HW-D-0570

TOP OF WALL JOINT : GYPSUM SHAFT WALL ASSEMBLY

ASSEMBLY RATING = 1-HR. OR 2-HR.

CLASS II MOVEMENT CAPABILITIES - 50% COMPRESSION OR EXTENSION

L-RATING AT AMBIENT = LESS THAN 1 CFM / LIN FT

L-RATING AT 400°F = LESS THAN 1 CFM / LIN FT

HW0570c.101013

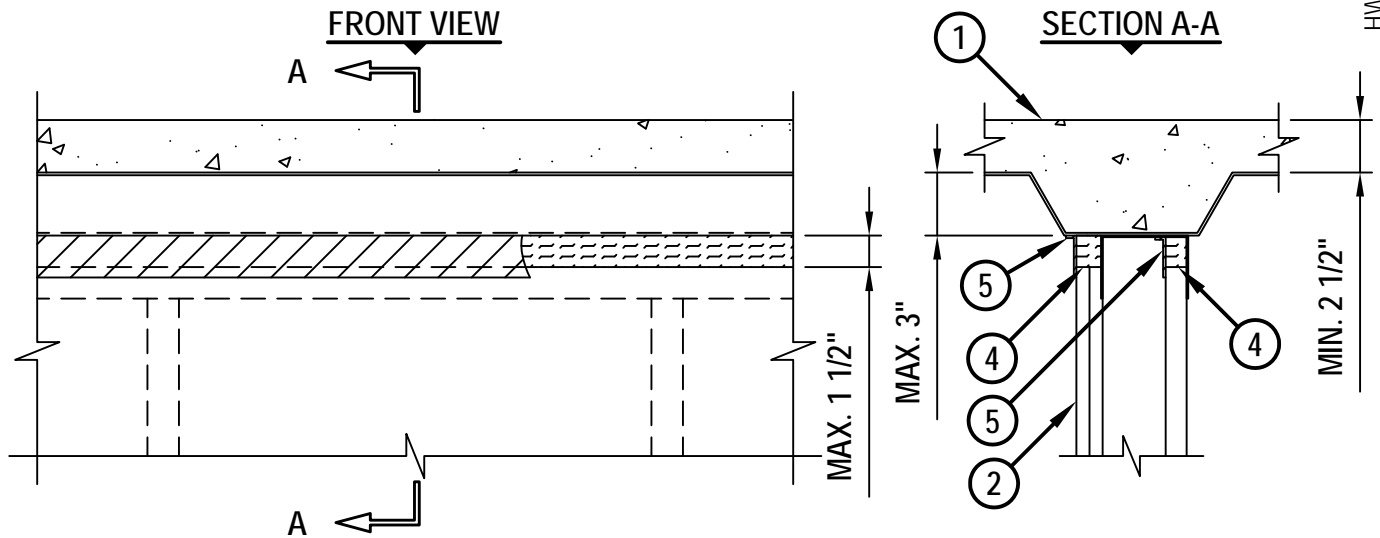

1. FLOOR OR ROOF ASSEMBLY (1-HR. OR 2-HR. FIRE-RATING) :

- A. LIGHTWEIGHT OR NORMAL WEIGHT CONCRETE FLOOR (MIN. 2-1/2" THICK) OVER METAL DECKING (UL/cUL CLASSIFIED D700 OR D900 SERIES).
- B. INSULATING CONCRETE (MIN. 2-1/4" THICK) OVER METAL DECKING (UL/cUL CLASSIFIED P900 SERIES).
- C. [NOT SHOWN] FLUTED STEEL ROOF DECK WITH SPRAY-APPLIED FIREPROOFING (UL/cUL CLASSIFIED P700 SERIES).



Hilti Firestop Systems

HILTI, Inc.
Tulsa, Oklahoma USA (800) 879-8000

Sheet	1 of 2
Scale	7/64" = 1"
Date	Oct. 10, 2013

Drawing No.

**HWD
0570c**

Saving Lives through Innovation and Education

TOP OF WALL JOINT : GYPSUM SHAFT WALL ASSEMBLY

ASSEMBLY RATING = 1-HR. OR 2-HR.

CLASS II MOVEMENT CAPABILITIES - 50% COMPRESSION OR EXTENSION

L-RATING AT AMBIENT = LESS THAN 1 CFM / LIN FT

L-RATING AT 400°F = LESS THAN 1 CFM / LIN FT

HWD0570c.101013

2. GYPSUM SHAFT WALL ASSEMBLY (UL/cUL CLASSIFIED U400 OR V400 SERIES) (1-HR. OR 2-HR. FIRE-RATING) (2-HR. SHOWN) TO INCLUDE THE FOLLOWING CONSTRUCTION FEATURES :
 - A. CEILING RUNNER, SIZED TO ACCOMMODATE STEEL STUDS. FLANGE HEIGHT OF CEILING RUNNER SHALL BE MINIMUM 1/4" GREATER THAN THE MAXIMUM EXTENDED JOINT WIDTH. RUNNER SECURED TO STEEL DECK VALLEYS WITH STEEL FASTENERS OR WELDS SPACED MAXIMUM 24" O/C.
 - B. "C-H" SHAPED STUDS (MINIMUM 4" WIDE, MINIMUM 25 GA.) CUT 3/4" TO 1" LESS IN LENGTH THAN ASSEMBLY HEIGHT, NESTING IN CEILING RUNNER WITHOUT ATTACHMENT.
 - C. NOMINAL 1" THICK GYPSUM LINER PANEL CUT 1-1/2" LESS IN LENGTH THAN ASSEMBLY HEIGHT. TYPE AND SHEET ORIENTATION AS SPECIFIED IN THE INDIVIDUAL UL DESIGN.
 - D. NOMINAL 5/8" THICK GYPSUM WALLBOARD CUT 1-1/2" LESS IN LENGTH THAN ASSEMBLY HEIGHT WITH SCREW ATTACHMENT 1" TO 1-1/2" BELOW THE BOTTOM OF THE CEILING RUNNER OR SLOTTED CEILING TRACK. TYPE, NUMBER OF LAYERS, AND SHEET ORIENTATION AS SPECIFIED IN THE INDIVIDUAL UL DESIGN.
3. [OPTIONAL - NOT SHOWN] WHEN SPRAY-APPLIED FIREPROOFING IS USED, CEILING RUNNER MAY BE SECURED TO DECK WITH Z-SHAPED CLIPS (MIN. 20 GA.) WITH THE FOLLOWING DIMENSIONS : MINIMUM 1" LONG, BUT NOT EXCEEDING THE WIDTH OF THE WALL, BY 1-1/2" OR 2" LONG UPPER AND LOWER LEGS. SUPPORT CLIPS SPACED MAXIMUM 24" OC.
4. HILTI CP 767 SPEED STRIPS OR MINERAL WOOL SAFING (MIN. 4 PCF DENSITY) COMPRESSED 50%, FLUSH WITH GYPSUM BOARD SURFACES.
5. MINIMUM 1/8" (WET) THICKNESS HILTI CFS-SP WB FIRESTOP JOINT SPRAY OR HILTI CP 672 SPEED SPRAY TO COMPLETELY COVER MINERAL WOOL AND OVERLAPPING MINIMUM 1/2" ONTO GYPSUM BOARD, CEILING RUNNER, AND METAL DECK.

- NOTES :
1. MAXIMUM WIDTH OF JOINT = 1-1/2".
 2. STEEL FLOOR UNITS MAY BE SPRAYED WITH A MINIMUM 5/16" TO MAXIMUM 1-3/4" THICKNESS OF UL CLASSIFIED MONOKOTE TYPE MK-6/HY (MANUFACTURED BY W.R. GRACE) OR CAFCO TYPE 300 (MANUFACTURED BY ISOLATEK, INT.) FIREPROOFING, PRIOR TO INSTALLATION OF CEILING RUNNERS.
 3. WHEN THE STEEL DECK IS COATED WITH FIREPROOFING, HILTI FIRESTOP JOINT SPRAY SHALL OVERLAP THE WALL A MINIMUM 1/2" AND OVERLAP THE FIREPROOFING A MINIMUM 2" ON BOTH SIDES OF GYPSUM WALL ASSEMBLY.
 4. AS AN ALTERNATE TO CEILING RUNNER IN ITEM NO. 2A, SLOTTED CEILING RUNNERS MAY BE USED. CONSULT THE UL FIRE RESISTANCE DIRECTORY FOR APPROVED MANUFACTURERS.



HILTI, Inc.
Tulsa, Oklahoma USA (800) 879-8000

Sheet	2 of 2
Scale	-
Date	Oct. 10, 2013

Drawing No.
**HWD
0570c**