

UL/cUL SYSTEM NO. HW-D-0634

TOP OF WALL JOINT : GYPSUM WALL ASSEMBLY

ASSEMBLY RATING = 1-HR. OR 2-HR.

L-RATING AT AMBIENT = LESS THAN 1 CFM / LIN FT

L-RATING AT 400°F = LESS THAN 1 CFM / LIN FT

CLASS II OR III MOVEMENT CAPABILITIES - 50% COMPRESSION OR EXTENSION

CROSS-SECTIONAL VIEW

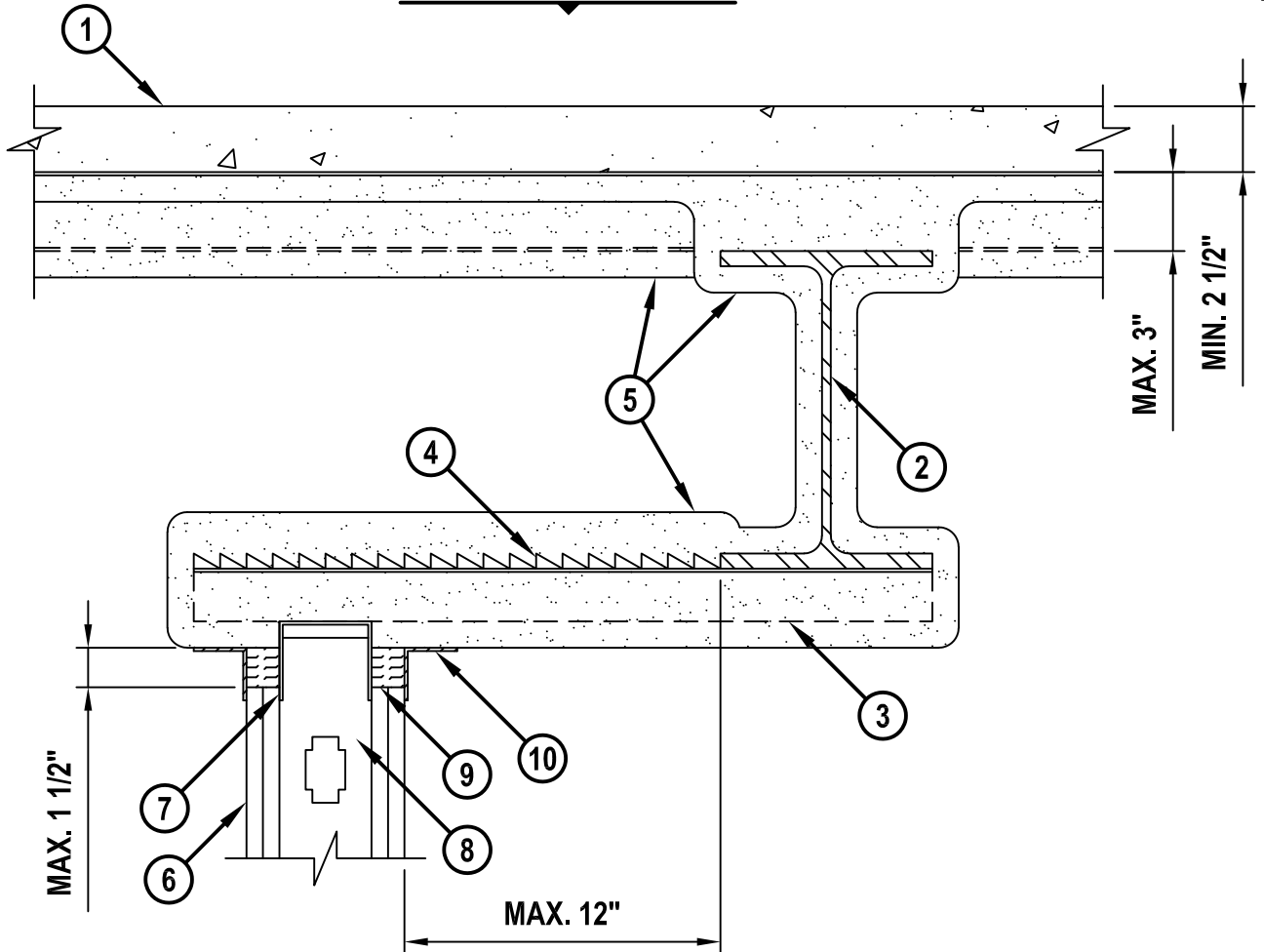

HW-D-0634b.102516



Hilti Firestop Systems

HILTI, Inc.
Plano, Texas USA (800) 879-8000

Sheet	1 of 2
Scale	9/64" = 1"
Date	Oct. 25, 2016

Drawing No.

**HWD
0634b**

Saving Lives through Innovation and Education

UL/cUL SYSTEM NO. HW-D-0634

TOP OF WALL JOINT : GYPSUM WALL ASSEMBLY

ASSEMBLY RATING = 1-HR. OR 2-HR.

L-RATING AT AMBIENT = LESS THAN 1 CFM / LIN FT

L-RATING AT 400°F = LESS THAN 1 CFM / LIN FT

CLASS II OR III MOVEMENT CAPABILITIES - 50% COMPRESSION OR EXTENSION

HWDD0634b.102516

1. LIGHTWEIGHT OR NORMAL WEIGHT CONCRETE FLOOR ASSEMBLY (MINIMUM 2-1/2" THICK) OVER METAL DECKING (UL/cUL CLASSIFIED D700 OR D900 SERIES) (1-HR. OR 2-HR. FIRE-RATING).
2. STRUCTURAL STEEL BEAM, AS SPECIFIED IN THE INDIVIDUAL D700 OR D900 SERIES DESIGN. STRUCTURAL STEEL BEAM ORIENTED PARALLEL TO AND MAXIMUM 12" FROM WALL ASSEMBLY.
3. NOMINAL 1-1/2" TO 2" PAINTED OR GALVANIZED Z-SHAPED BARS OR CHANNELS (MIN. 16 GA.) WELDED OR FASTENED WITH STEEL FASTENERS TO BEAM SPACED MAXIMUM 24" O/C.
4. NOMINAL 3/8" DIAMOND MESH EXPANDED STEEL LATH (NOMINAL WEIGHT 3.4 LB/YD²) INSTALLED OVER AND SECURED TO THE STEEL FURRING BARS OR CHANNELS WITH STEEL FASTENERS OR TIE WIRE.
5. UL/cUL CLASSIFIED MONOKOTE TYPE MK-6/HY, MK-6/HY ES, MK-6S, OR RG (MANUFACTURED BY W.R. GRACE) OR TYPE 300 (MANUFACTURED BY ISOLATEK, INT.) FIREPROOFING SPRAYED ON STEEL BEAM AND DECK (AS APPLICABLE) TO THE THICKNESS SPECIFIED IN THE INDIVIDUAL D700 OR D900 SERIES DESIGN. FIREPROOFING TO COMPLETELY FILL FLUTES ABOVE THE STRUCTURAL STEEL BEAM, FULLY COVER FURRING MEMBER TO THE MINIMUM THICKNESS OF MATERIAL REQUIRED ON THE FLANGES OF STEEL BEAM, AND COMPLETELY FILLING THE SPACE BETWEEN THE BAR/CHANNEL FURRING ABOVE THE WALL (SEE NOTES NO. 2 AND 3 BELOW).
6. GYPSUM WALL ASSEMBLY (UL/cUL CLASSIFIED U400 OR V400 SERIES) (1-HR. OR 2-HR. FIRE-RATING) (2-HR. SHOWN).
7. CEILING RUNNER WITH FLANGE HEIGHT A MINIMUM 1/4" GREATER THAN MAXIMUM EXTENDED JOINT WIDTH. CEILING RUNNER SECURED TO STEEL FURRING WITH STEEL FASTENERS OR WELDS AT MAXIMUM 24" ON CENTER.
8. STEEL STUDS (MINIMUM 3-1/2" WIDE) CUT 1/2" TO 3/4" LESS IN LENGTH THAN ASSEMBLY HEIGHT, NESTING IN CEILING RUNNER WITHOUT ATTACHMENT.
9. HILTI CP 767 SPEED STRIPS OR MINERAL WOOL SAFING (MIN. 4 PCF DENSITY) COMPRESSED 50% AND INSERTED INTO JOINT, FLUSH WITH BOTH SIDES OF WALL.
10. MINIMUM 1/8" (WET) THICKNESS HILTI CFS-SP WB FIRESTOP JOINT SPRAY TO COMPLETELY COVER MINERAL WOOL, OVERLAPPING MINIMUM 1/2" ONTO GYPSUM WALL AND MINIMUM 2" ONTO FIREPROOFING.

NOTES :

1. MAXIMUM WIDTH OF JOINT = 1-1/2".
2. THE TOTAL THICKNESS OF FIREPROOFING TO BE APPLIED TO THE WEB OF THE STEEL BEAM ON EACH SIDE OF THE WALL SHALL BE MINIMUM 13/16" AND 1-3/8" THICKNESS FOR 1-HR. OR 2-HR. WALLS, RESPECTIVELY (WHEN USING MONOKOTE) OR 11/16" AND 1-1/2" THICKNESS FOR 1-HR. OR 2-HR. WALLS, RESPECTIVELY (WHEN USING TYPE 300 FIREPROOFING).
3. THE THICKNESS OF FIREPROOFING APPLIED TO THE EXPANDED STEEL LATH SHALL COVER THE TOP SURFACE OF THE LATH WITH A MINIMUM 1-5/8" AND 2-5/8" THICKNESS FOR 1-HR. AND 2-HR. WALLS, RESPECTIVELY.



Hilti Firestop Systems

HILTI, Inc.
Plano, Texas USA (800) 879-8000

Sheet	2 of 2
Scale	-
Date	Oct. 25, 2016

Drawing No.

**HWD
0634b**

Saving Lives through Innovation and Education