

MULTIPLE PLASTIC PIPES THROUGH CONCRETE WALL OR BLOCK WALL ASSEMBLY

F-RATING = 2-HR.

T-RATING = 0-HR.

NOTE : TESTED WITH A 2.5 Pa PRESSURE DIFFERENTIAL

FRONT VIEW

SECTION A-A

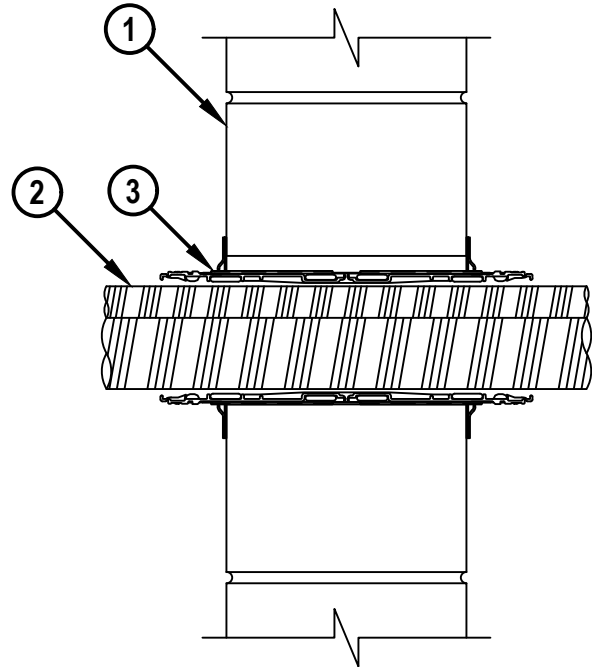
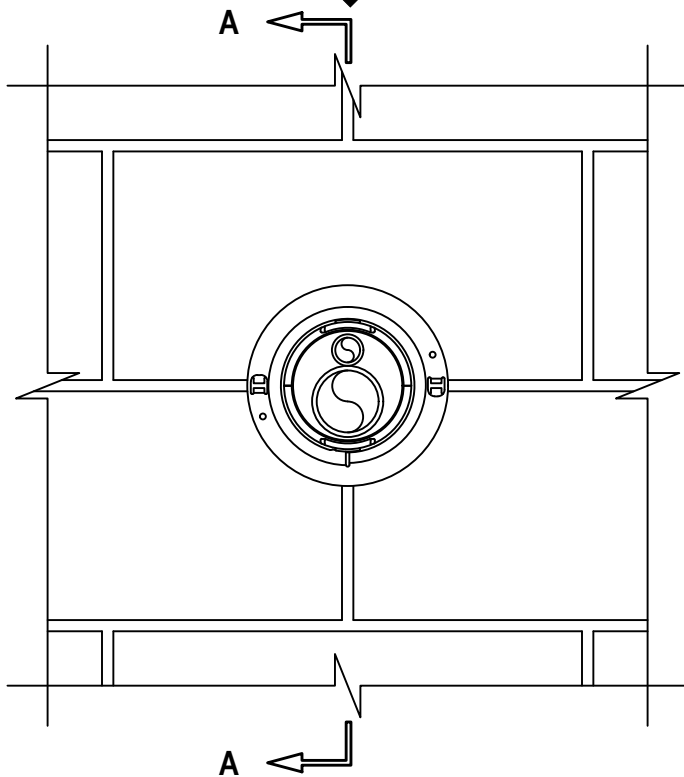

WJ2230f.032823

1. CONCRETE WALL ASSEMBLY (2-HR. FIRE-RATING) :
 - A. LIGHTWEIGHT OR NORMAL WEIGHT CONCRETE WALL (MINIMUM 5-5/8" THICK).
 - B. ANY UL CLASSIFIED CONCRETE BLOCK WALL.
2. ONE OR MORE MAXIMUM 2" NOMINAL DIAMETER ENT (FORMED FROM PVC).
3. HILTI CP 653 (BA) SPEED SLEEVE [2" OR 4"] OR HILTI CFS-SL GA L SPEED SLEEVE [4"] SLID INTO AND CENTERED WITHIN WALL. DEVICE FLANGES SPUN CLOCKWISE ONTO DEVICE THREADS OVER SMOKE GASKET, BUTTING TIGHTLY TO BOTH SIDES OF WALL.

- NOTES :**
1. MAXIMUM DIAMETER OF OPENING = 2-1/2" (FOR 2" DEVICE) OR 4-1/2" (FOR 4" DEVICE).
 2. HILTI CFS-SL GA L SPEED SLEEVE SHALL ONLY BE USED IN WALLS 8" THICK OR GREATER.
 3. ANNULAR SPACE BETWEEN DEVICE AND PERIPHERY OF OPENING = MINIMUM 0".
 4. [OPTIONAL] AS AN ALTERNATE TO SMOKE GASKET, MINIMUM 1/2" DEPTH HILTI FS-ONE MAX INTUMESCENT FIRESTOP SEALANT OR HILTI CP 606 FLEXIBLE FIRESTOP SEALANT FLUSH WITH BOTH SURFACES OF WALL WITH AN ADDITIONAL 1/4" BEAD APPLIED AROUND PERIPHERY OF DEVICE PRIOR TO SECURING DEVICE FLANGES.



HILTI, Inc.
Plano, Texas USA (800) 879-8000

Sheet	1 of 1
Scale	5/32" = 1"
Date	Mar. 28, 2023

Drawing No.
WJ
2230f