

SUPPORT MEMBER THROUGH CONCRETE WALL OR BLOCK WALL ASSEMBLY

F-RATING = 2-HR.

T-RATING = 0-HR.

L-RATING AT AMBIENT = LESS THAN 1 CFM / SQ FT

L-RATING AT 400°F = LESS THAN 1 CFM / SQ FT

WJ7110b.010915

FRONT VIEW

A ←

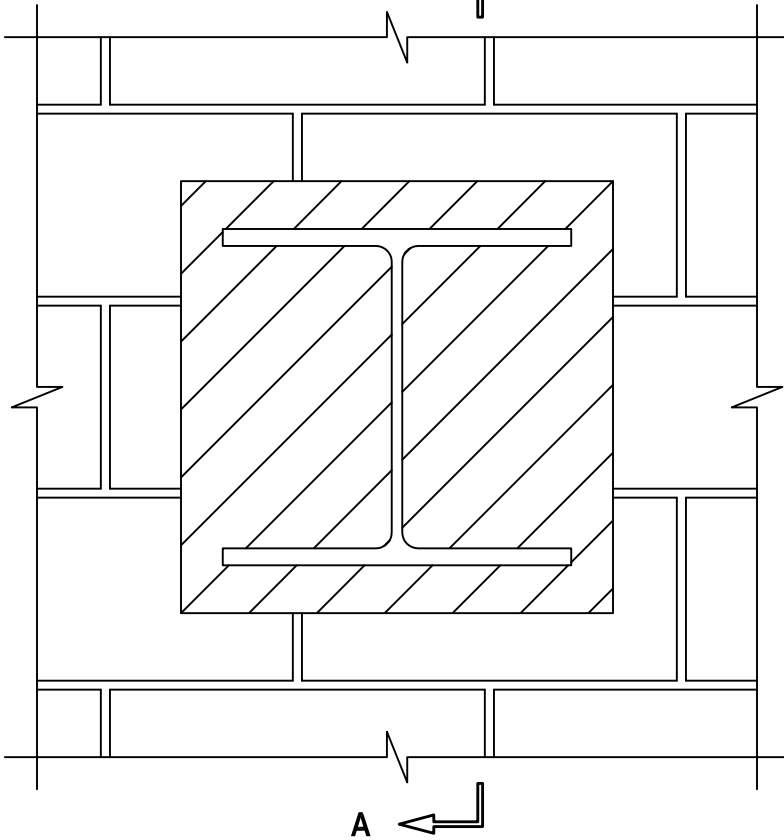

SECTION A-A

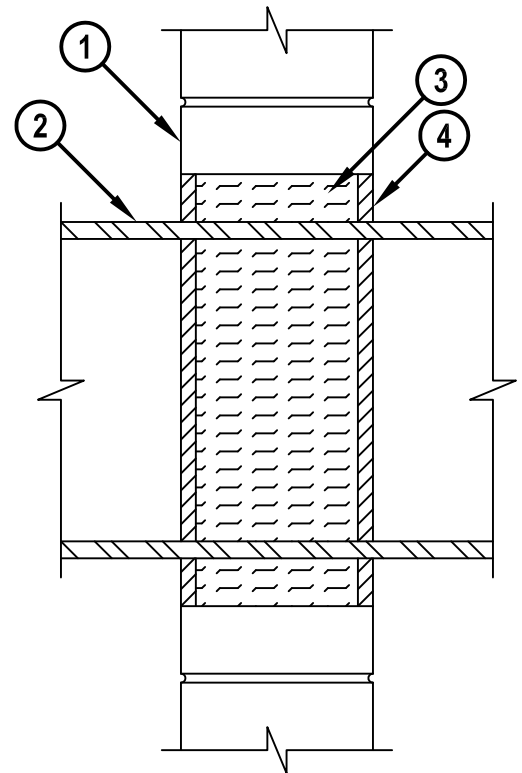

1. CONCRETE WALL ASSEMBLY (2-HR. FIRE-RATING) :

- A. LIGHTWEIGHT OR NORMAL WEIGHT CONCRETE WALL (MINIMUM 6" THICK).
- B. ANY UL/cUL CLASSIFIED CONCRETE BLOCK WALL.

2. STEEL I-BEAM SERVICE SUPPORT (MAXIMUM SIZE : W14x90).

3. MINERAL WOOL (MIN. 4 PCF DENSITY) TIGHTLY PACKED, RECESSED TO ACCOMMODATE SEALANT.

4. MINIMUM 5/8" DEPTH HILTI FS-ONE MAX OR FS-ONE INTUMESCENT FIRESTOP SEALANT.

NOTES : 1. MAXIMUM SIZE OF OPENING = 324 SQ. IN., WITH A MAXIMUM DIMENSION OF 18".
2. ANNULAR SPACE = MINIMUM 1/2", MAXIMUM 3".



HILTI, Inc.
 Tulsa, Oklahoma USA (800) 879-8000

Sheet	1 of 1
Scale	1/8" = 1"
Date	Jan. 09, 2015

Drawing No.
WJ
7110b