

METAL PIPE THROUGH GYPSUM SHAFT WALL ASSEMBLY

F-RATING = 2-HR.

T-RATING = 0-HR.

WL1380c.011215

FRONT VIEW

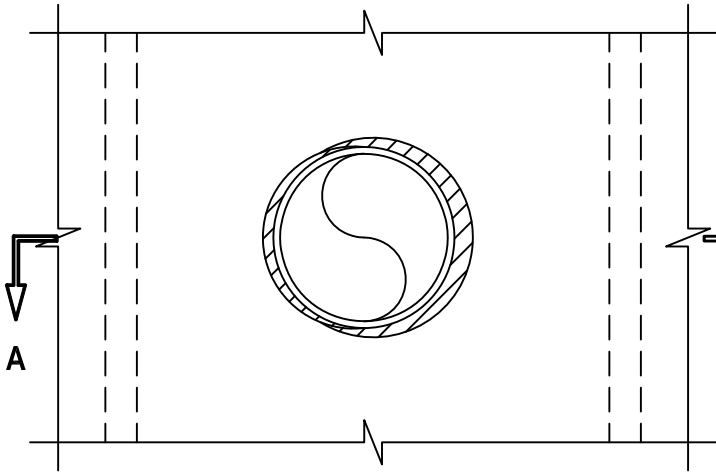

SECTION A-A

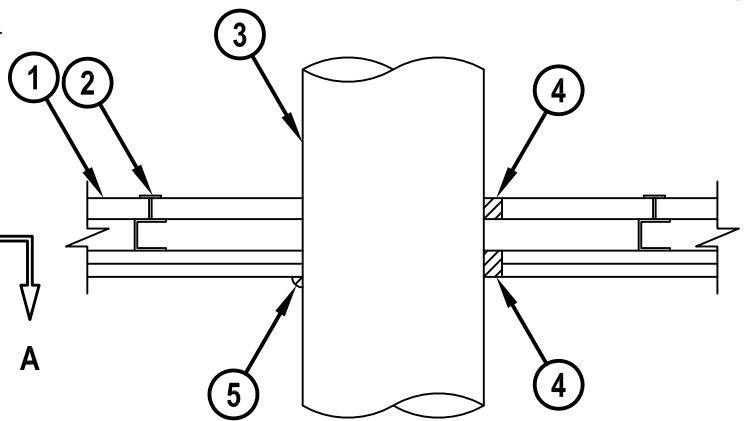

1. GYPSUM SHAFT WALL ASSEMBLY (UL/cUL CLASSIFIED U400 OR V400 SERIES) (2-HR. FIRE-RATING).
2. "C-T" OR "C-H" SHAPED STEEL STUDS (MINIMUM 1-1/2" DEEP x 2-1/2" WIDE, MIN. 25 GA.) SPACED MAXIMUM 24" C/C.
3. PENETRATING ITEM TO BE ONE OF THE FOLLOWING :
 - A. MAXIMUM 8" NOMINAL DIAMETER STEEL PIPE (SCHEDULE 10 OR HEAVIER).
 - B. MAXIMUM 8" NOMINAL DIAMETER DIAMETER CAST OR DUCTILE IRON PIPE.
 - C. MAXIMUM 6" NOMINAL DIAMETER COPPER PIPE OR TUBING.
 - D. MAXIMUM 6" NOMINAL DIAMETER STEEL CONDUIT.
 - E. MAXIMUM 4" NOMINAL DIAMETER EMT.
4. MINIMUM 1" DEPTH HILTI FS-ONE MAX OR FS-ONE INTUMESCENT FIRESTOP SEALANT FLUSH WITH EACH SURFACE OF WALL ASSEMBLY.
5. MINIMUM 1/2" BEAD HILTI FS-ONE MAX OR FS-ONE INTUMESCENT FIRESTOP SEALANT APPLIED AT POINT OF CONTACT ON FINISHED SIDE OF SHAFT WALL.

NOTES : 1. MAXIMUM DIAMETER OF OPENING = 9-1/2".
 2. ANNULAR SPACE = MINIMUM 0", MAXIMUM 7/8".



HILTI, Inc.
 Tulsa, Oklahoma USA (800) 879-8000

Sheet	1 of 1
Scale	7/64" = 1"
Date	Jan. 12, 2015

Drawing No.
**WL
 1380c**