

UL SYSTEM NO. W-L-2335

PLASTIC PIPE THROUGH GYPSUM WALL ASSEMBLY

F-RATING = 1-HR. OR 2-HR.

T-RATING = 3/4-HR., 1-HR., OR 1-1/2-HR.

WL2335c.011215

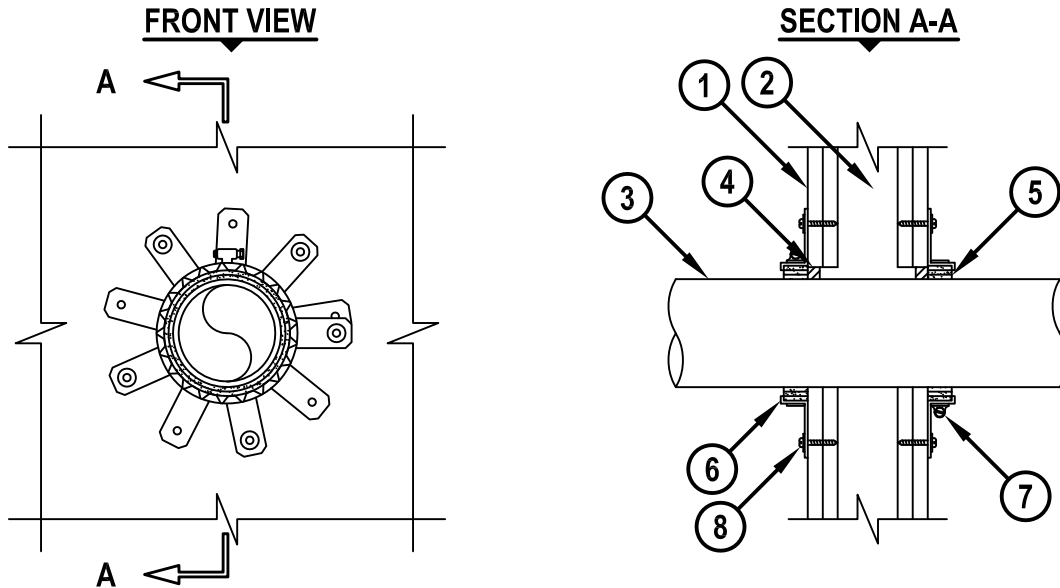

1. GYPSUM WALL ASSEMBLY (UL CLASSIFIED U300 OR U400 SERIES) (1-HR. OR 2-HR. FIRE-RATING) (2-HR. SHOWN).
2. [NOT SHOWN] WOOD STUDS TO CONSIST OF NOMINAL 2" x 4" LUMBER. STEEL STUDS TO BE MINIMUM 2-1/2" WIDE.
3. PENETRATING ITEM TO BE ONE OF THE FOLLOWING (ALSO SEE NOTE NO. 3 BELOW) :
 - A. MAXIMUM 4" NOMINAL DIAMETER PVC PLASTIC PIPE (CELLULAR OR SOLID CORE).
 - B. MAXIMUM 4" NOMINAL DIAMETER ABS PLASTIC PIPE (CELLULAR OR SOLID CORE).
 - C. MAXIMUM 4" NOMINAL DIAMETER CPVC PLASTIC PIPE (CLOSED PIPING SYSTEM ONLY).
4. MINIMUM 1/4" DEPTH HILTI FS-ONE MAX OR FS-ONE INTUMESCENT FIRESTOP SEALANT.
5. HILTI CP 648E WRAP STRIP (NOMINAL 3/16" THICK x 1" WIDE) CONTINUOUSLY WRAPPED AROUND THE OUTER CIRCUMFERENCE OF THE PIPE, AS SPECIFIED IN THE TABLE BELOW, AND HELD IN PLACE WITH TAPE.
6. HILTI RETAINING COLLAR WRAPPED OVER WRAP STRIPS, OVERLAPPING MINIMUM 1".
7. NOMINAL 1/2" WIDE STAINLESS STEEL HOSE CLAMP FASTENED AT MID-HEIGHT OF RETAINING COLLAR.
8. EVERY OTHER TAB OF RETAINING COLLAR SECURED TO GYPSUM WALL WITH 1-1/4" LONG STEEL LAMINATE DRYWALL SCREWS IN CONJUNCTION WITH 1-1/4" DIAMETER FENDER WASHERS.

NOMINAL PIPE DIAMETER	NO. OF LAYERS OF CP 648E
2" (OR SMALLER)	2
4" (OR SMALLER)	3

NOTES : 1. MAXIMUM DIAMETER OF OPENING = 5".
 2. ANNULAR SPACE = MINIMUM 0", MAXIMUM 1/2".
 3. CLOSED OR VENTED PIPING SYSTEMS (PVC & ABS = SCHEDULE 40; CPVC = SDR 13.5).



HILTI, Inc.
 Tulsa, Oklahoma USA (800) 879-8000

Sheet	1 of 1
Scale	1/8" = 1"
Date	Jan. 12, 2015

Drawing No.
WL
2335c