

**CABLE BUNDLE THROUGH GYPSUM WALL ASSEMBLY**

F-RATING = 1-HR. OR 2-HR.

T-RATING = 0-HR.

WL3111c.111008

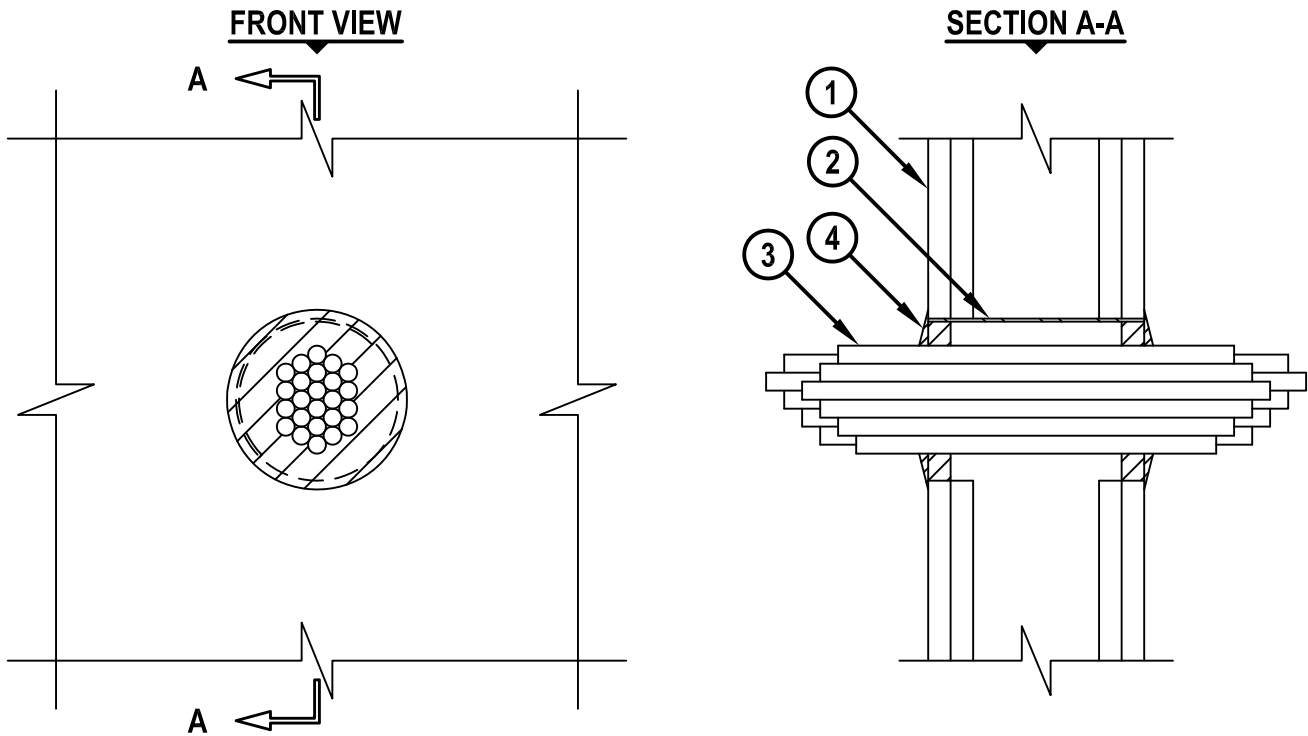

1. GYPSUM WALL ASSEMBLY (UL/cUL CLASSIFIED U300 OR U400 SERIES) (1-HR OR 2-HR FIRE-RATING) (2-HR. SHOWN).
2. [OPTIONAL] MAXIMUM 4" NOMINAL DIAMETER EMT SLEEVE OR STEEL PIPE SLEEVE (SCHEDULE 5) (ALSO SEE NOTE NO. 5 BELOW).
3. CABLE BUNDLE TO CONSIST OF ANY OF THE FOLLOWING :
  - A. RG 59 COAXIAL CABLE.
  - B. MAXIMUM 6 PAIR NO. 24 AWG TELEPHONE CABLE.
  - C. 24 FIBER-OPTIC CABLE (MAXIMUM 1/4" DIAMETER).
  - D. ROMEX (2/C NO. 12 +GRND).
  - E. MAXIMUM 3/C NO. 12 AWG METAL-CLAD CABLE.
4. MINIMUM 5/8" DEPTH HILTI CP 618 FIRESTOP PUTTY STICK WITH ADDITIONAL 1/4" CROWN AROUND CABLES (ALSO SEE NOTE NO. 4 BELOW).

**NOTES :** 1. MAXIMUM DIAMETER OF OPENING = 4".  
 2. ANNULAR SPACE = MINIMUM 1/8", MAXIMUM 3/4".  
 3. CABLES TO FILL A MAXIMUM 25% OF CROSS-SECTIONAL AREA OF OPENING.  
 4. HILTI CP 618 FIRESTOP PUTTY STICK TO BE FORCED INTO INTERSTICES OF CABLES TO MAXIMUM EXTENT POSSIBLE.  
 5. WHEN USING A STEEL SLEEVE, APPLY HILTI CP 618 PUTTY STICK ONTO WALL SURFACE COMPLETELY COVERING SLEEVE.



HILTI, Inc.  
 Tulsa, Oklahoma USA (800) 879-8000

Sheet	1 of 1
Scale	3/16" = 1"
Date	Nov. 10, 2008

Drawing No.  
**WL  
 3111c**