

UL/cUL SYSTEM NO. W-L-3384

CABLE BUNDLES THROUGH GYPSUM WALL ASSEMBLY

F-RATING = 1-HR. OR 2-HR.

T-RATING = 1/2-HR. OR 1 1/2-HR.

L-RATING AT AMBIENT = LESS THAN 1 CFM PER DEVICE (SEE TABLE BELOW)

L-RATING AT 400°F = 1 OR LESS THAN 1 CFM PER DEVICE (SEE TABLE BELOW)

WL3384g.072518

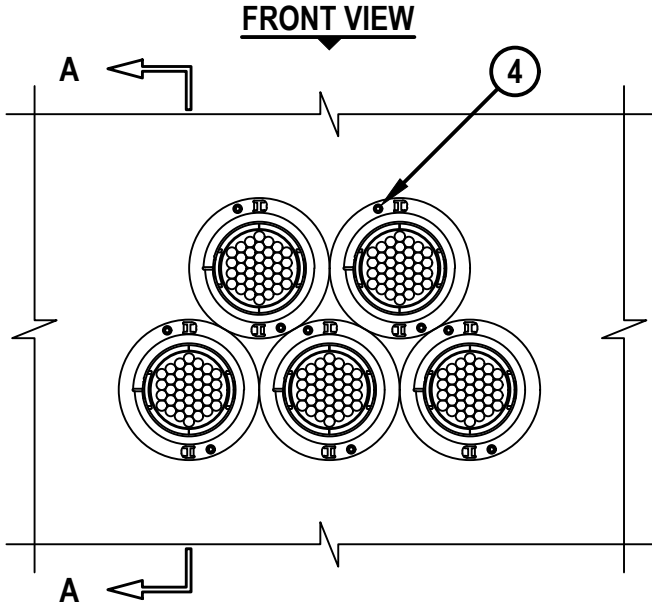

CONFIGURATION A

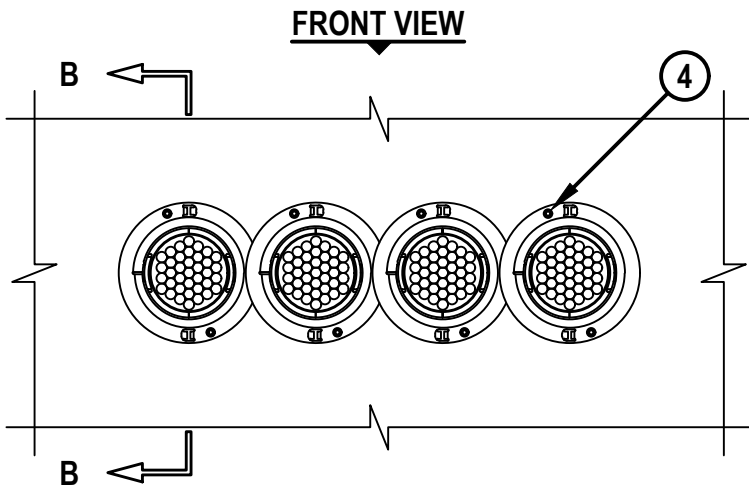
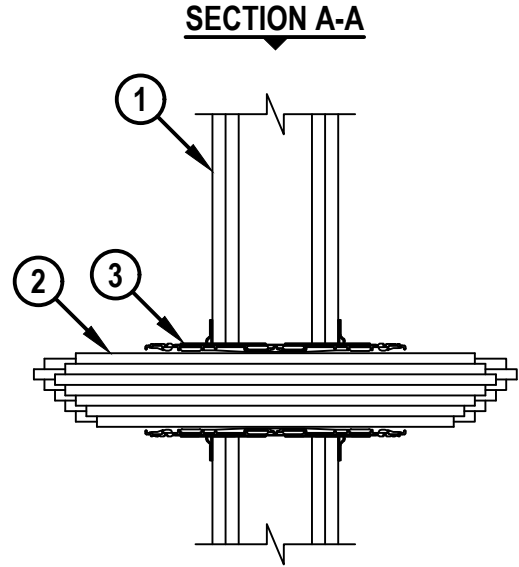

CONFIGURATION B

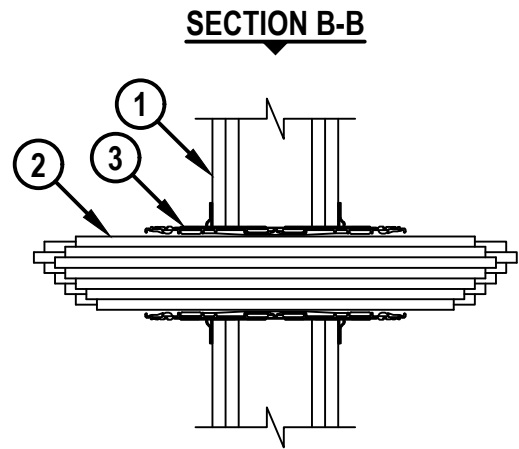

HILTI, Inc.
Plano, Texas USA (800) 879-8000

Sheet	1 of 3
Scale	7/64" = 1"
Date	July 25, 2018

Drawing No.
WL
3384g

Saving Lives through Innovation and Education

CABLE BUNDLES THROUGH GYPSUM WALL ASSEMBLY

F-RATING = 1-HR. OR 2-HR.

T-RATING = 1/2-HR. OR 1 1/2-HR.

L-RATING AT AMBIENT = LESS THAN 1 CFM PER DEVICE (SEE TABLE BELOW)

L-RATING AT 400°F = 1 OR LESS THAN 1 CFM PER DEVICE (SEE TABLE BELOW)

WL3384g.072518

1. GYPSUM WALL ASSEMBLY (UL/cUL CLASSIFIED U400, V400, OR W400 SERIES) (1-HR. OR 2-HR. FIRE-RATING) (2-HR. SHOWN) TO INCLUDE THE FOLLOWING CONSTRUCTION FEATURES :
 - A. [NOT SHOWN] STEEL STUDS TO BE MINIMUM 3-1/2" WIDE (SPACED MAXIMUM 24" OC).
 - B. NOMINAL 5/8" THICK GYPSUM WALLBOARD. TYPE, NUMBER OF LAYERS, AND SHEET ORIENTATION AS SPECIFIED IN THE INDIVIDUAL UL DESIGN.
2. CABLE BUNDLE TO BE A COMBINATION OF ANY OF THE FOLLOWING :
 - A. MAXIMUM 100 PAIR NO. 24 AWG TELEPHONE CABLE WITH PVC JACKET.
 - B. MAXIMUM 7/C NO. 12 AWG COPPER CONDUCTOR CONTROL CABLE WITH PVC OR XLPE JACKET AND INSULATION.
 - C. MAXIMUM 4/0 AWG TYPE RHH GROUND CABLE.
 - D. MAXIMUM 4 PAIR NO. 22 AWG CAT 5 OR CAT 6 COMPUTER CABLE.
 - E. MAXIMUM RG 6/U COAXIAL CABLE.
 - F. MAXIMUM 1/2" DIAMETER FIBER-OPTIC CABLE (24 FIBER) WITH PVC OR PE JACKET AND INSULATION.
 - G. MAXIMUM 20/C NO. 22 AWG SHIELDED PRINTER CABLE WITH PVC JACKET.
 - H. MAXIMUM 2/C NO. 18 AWG POWER OR NON-POWER LIMITED FIRE ALARM CABLE WITH OR WITHOUT METAL JACKET (MANUFACTURED BY AFC CABLE SYSTEMS, INC.).
 - I. MAXIMUM 1/4" DIAMETER S-VIDEO CABLE CONSISTING OF TWO MAXIMUM 24 AWG 75 OHM COAX OR TWISTED PAIR CABLE WITH PE INSULATION AND PVC JACKET.
 - J. MAXIMUM 3/C NO. 12 AWG METAL CLAD CABLE.
 - K. ANY CABLES, METAL-CLAD CABLES, OR ARMORED CABLES CURRENTLY LISTED UNDER THE THROUGH PENETRATING PRODUCTS CATEGORY.

CONFIGURATION A

3. MAXIMUM FIVE HILTI CP 653 (BA) SPEED SLEEVE [2" OR 4"] OR HILTI CFS-SL GA L SPEED SLEEVE [4"] GROUPED IN A TWO ROW CONFIGURATION. INDIVIDUAL OPENINGS ARE SPACED MINIMUM 2-7/16" APART SUCH THAT DEVICE FLANGES OF ADJACENT DEVICES ARE NO CLOSER THAN POINT CONTACT. HILTI SPEED SLEEVE SLID INTO AND CENTERED WITHIN WALL. DEVICE FLANGES SPUN CLOCKWISE ONTO DEVICE THREADS OVER SMOKE GASKET, BUTTING TIGHTLY TO WALL SURFACES. INNER FABRIC MAY REMAIN OPEN EXCEPT FOR WHEN DEVICE CONTAINS NO CABLES AND WHEN L-RATING IS REQUIRED.
4. SECURE DEVICE FLANGES TO BOTH SIDES OF WALL WITH TWO MINIMUM 1-1/2" LONG DRYWALL SCREWS.



HILTI, Inc.
Plano, Texas USA (800) 879-8000

Sheet	2 of 3
Scale	-
Date	July 25, 2018

Drawing No.

**WL
3384g**

CABLE BUNDLES THROUGH GYPSUM WALL ASSEMBLY

F-RATING = 1-HR. OR 2-HR.

T-RATING = 1/2-HR. OR 1 1/2-HR.

L-RATING AT AMBIENT = LESS THAN 1 CFM PER DEVICE (SEE TABLE BELOW)

L-RATING AT 400°F = 1 OR LESS THAN 1 CFM PER DEVICE (SEE TABLE BELOW)

WL3384g.072518

CONFIGURATION B

3. MAXIMUM FOUR HILTI CP 653 (BA) SPEED SLEEVE [2" OR 4"] OR HILTI CFS-SL GA L SPEED SLEEVE [4"] GROUPED IN ONE ROW. INDIVIDUAL OPENINGS ARE SPACED MINIMUM 1-7/16" APART. DEVICE FLANGES MAY OVERLAP ONE ANOTHER. HILTI SPEED SLEEVE SLID INTO AND CENTERED WITHIN WALL. DEVICE FLANGES SPUN CLOCKWISE ONTO DEVICE THREADS OVER SMOKE GASKET, BUTTING TIGHTLY TO WALL SURFACES. INNER FABRIC MAY REMAIN OPEN EXCEPT FOR WHEN L-RATING IS REQUIRED.
4. SECURE DEVICE FLANGES TO BOTH SIDES OF WALL WITH TWO MINIMUM 1-1/2" LONG DRYWALL SCREWS.

MAX CABLE FILL	CABLE TYPE	L-RATING, CFM			
		AMBIENT		400°F	
		SEALANT	GASKET	SEALANT	GASKET
0% FILL	-	LESS THAN 1	LESS THAN 1	LESS THAN 1	LESS THAN 1
100%	ITEM 2D ONLY	LESS THAN 1	LESS THAN 1	LESS THAN 1	LESS THAN 1
100%	ANY CABLES (ITEM 2) IN ANY COMBINATION	1.2	1.2	1.3	1.6

- NOTES :**
1. MAXIMUM DIAMETER OF OPENING = 2-1/2" (FOR 2" DEVICES) OR 4-1/2" (FOR 4" DEVICES).
 2. HILTI CFS-SL GA L SPEED SLEEVE SHALL ONLY BE USED IN WALLS 8" THICK OR GREATER.
 3. CABLES MAY REPRESENT 0% TO 100% VISUAL FILL OF DEVICE.
 4. L-RATING APPLIES ONLY WHEN INNER FABRIC SEAL IS TWISTED CLOSED.
 5. [OPTIONAL - FOR CONFIGURATION A OR B] AS AN ALTERNATE TO SMOKE GASKET, MINIMUM 1/4" BEAD HILTI FS-ONE MAX INTUMESCENT FIRESTOP SEALANT OR HILTI CP 606 FLEXIBLE FIRESTOP SEALANT APPLIED AROUND PERIPHERY OF EACH DEVICE ON BOTH SIDES OF WALL PRIOR TO SECURING DEVICE FLANGES.



HILTI, Inc.
Plano, Texas USA (800) 879-8000

Sheet 3 of 3

Scale -

Date July 25, 2018

Drawing No.

**WL
3384g**