

MULTIPLE PENETRATING ITEMS THROUGH GYPSUM WALL ASSEMBLY

F-RATING = 1-HR. OR 2-HR.

T-RATING = 0-HR., 1/2-HR., 3/4-HR., 1 1/2-HR., OR 2-HR.

NOTE : TESTED WITH A 2.5 Pa PRESSURE DIFFERENTIAL

WL8079e.051917

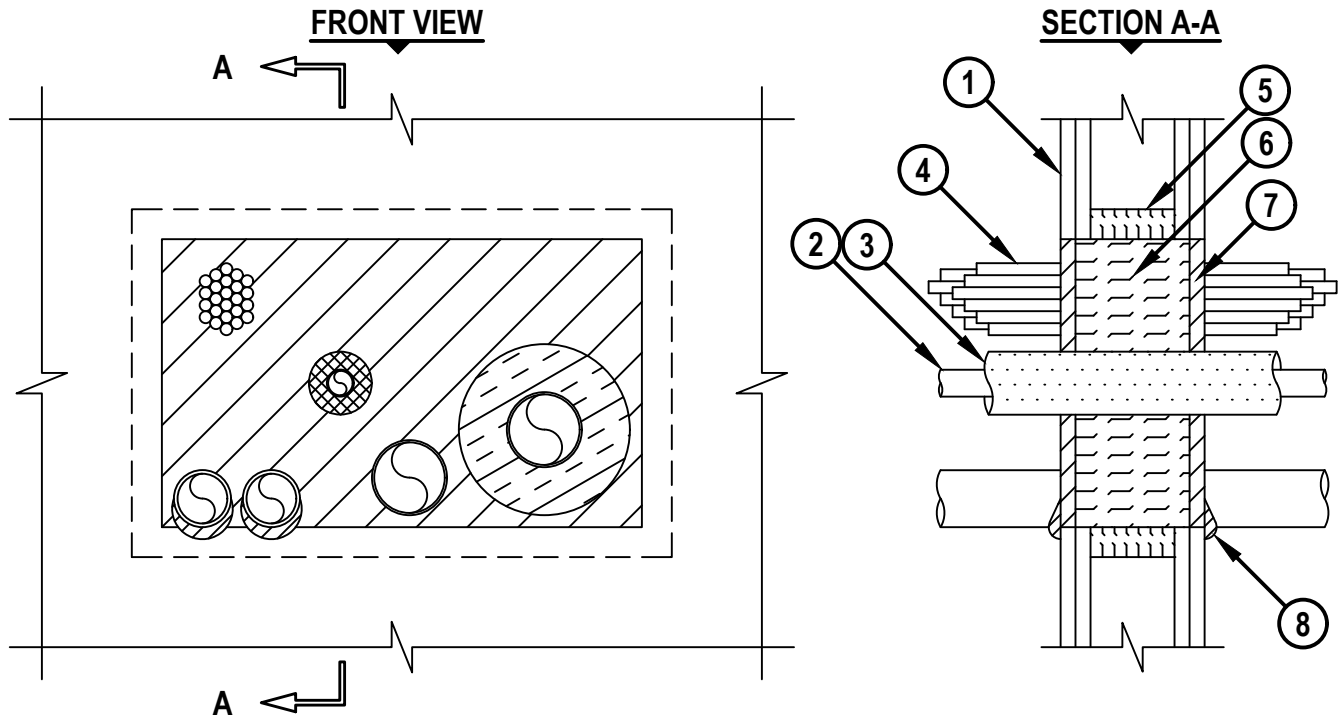

1. GYPSUM WALL ASSEMBLY (UL/cUL CLASSIFIED U300, U400, V400, OR W400 SERIES) (1-HR. OR 2-HR. FIRE-RATING) (2-HR. SHOWN) TO INCLUDE THE FOLLOWING CONSTRUCTION FEATURES :
 - A. [NOT SHOWN] WOOD STUDS TO CONSIST OF NOMINAL 2" x 4" LUMBER (SPACED MAXIMUM 16" OC). STEEL STUDS TO BE MINIMUM 3-1/2" WIDE (SPACED MAXIMUM 24" OC).
 - B. NOMINAL 5/8" THICK GYPSUM WALLBOARD. TYPE, NUMBER OF LAYERS, AND SHEET ORIENTATION AS SPECIFIED IN THE INDIVIDUAL UL DESIGN.
2. ONE OR MORE OF THE FOLLOWING PIPES, AND IN ANY COMBINATION MAY BE INSTALLED WITHIN THE OPENING :
 - A. MAXIMUM 4" NOMINAL DIAMETER STEEL PIPE (SCH 10 OR HEAVIER).
 - B. MAXIMUM 4" NOMINAL DIAMETER CAST OR DUCTILE IRON PIPE.
 - C. MAXIMUM 3" NOMINAL DIAMETER COPPER PIPE OR TUBING.
 - D. MAXIMUM 3" NOMINAL DIAMETER STEEL CONDUIT OR EMT.
 - E. MAXIMUM 2" NOMINAL DIAMETER PVC PLASTIC PIPE (SCH 40) (CELLULAR OR SOLID CORE) (VENTED OR CLOSED PIPING SYSTEM) (SEE NOTE NO. 5 BELOW).
 - F. MAXIMUM 2" NOMINAL DIAMETER CPVC PLASTIC PIPE (SDR 13.5) (CLOSED PIPING SYSTEM) (SEE NOTE NO. 5 BELOW).



HILTI, Inc.
Plano, Texas USA (800) 879-8000

Sheet	1 of 2
Scale	1/8" = 1"
Date	May 19, 2017

Drawing No.
**WL
8079f**

MULTIPLE PENETRATING ITEMS THROUGH GYPSUM WALL ASSEMBLY

F-RATING = 1-HR. OR 2-HR.

T-RATING = 0-HR., 1/2-HR., 3/4-HR., 1 1/2-HR., OR 2-HR.

NOTE : TESTED WITH A 2.5 Pa PRESSURE DIFFERENTIAL

WL8079e.051917

3. [OPTIONAL] ONE OR MORE METALLIC PIPES MAY BE INSULATED WITH THE FOLLOWING TYPES OF PIPE INSULATION :
 - A. MINIMUM 1" TO MAXIMUM 2" THICK GLASS-FIBER PIPE INSULATION (3.5 PCF DENSITY).
 - B. MINIMUM 1/2" TO MAXIMUM 3/4" THICK AB/PVC PIPE INSULATION.
4. ONE MAXIMUM 3" DIAMETER CABLE BUNDLE CONSISTING OF ANY OF THE FOLLOWING :
 - A. MAXIMUM 25 PAIR NO. 24 AWG TELEPHONE CABLE WITH PVC JACKET.
 - B. MAXIMUM 7/C NO. 12 AWG COPPER CONDUCTOR POWER CABLE WITH PVC JACKET.
 - C. MAXIMUM 1/2" DIAMETER FIBER-OPTIC CABLE WITH PVC JACKET.
 - D. MAXIMUM 3/C NO. 8 AWG, WITH BARE ALUMINUM GROUND, STEEL METAL CLAD CABLE.
 - E. MAXIMUM 3/C (WITH GROUND) NO. 8 AWG NONMETALLIC SHEATHED CABLE (ROMEX) WITH PVC JACKET.
 - F. MAXIMUM 1/2" DIAMETER RG/U COAXIAL CABLE WITH PVC JACKET.
 - G. MAXIMUM 3/4" DIAMETER COPPER GROUND CABLE WITH OR WITHOUT PVC JACKET.
 - H. MAXIMUM 1-1/4" DIAMETER SINGLE OR MULTI-CONDUCTOR MINERAL-INSULATED COPPER-CLAD CABLE.
5. MINIMUM 1-1/4" THICKNESS MINERAL WOOL (MIN. 4 PCF DENSITY) TIGHTLY PACKED AS A BACKER AROUND THE PERIMETER OF THE OPENING (SEE NOTE NO. 6 BELOW).
6. MINIMUM 3-1/2" OR 4-3/4" THICKNESS MINERAL WOOL (MIN. 4 PCF DENSITY) TIGHTLY PACKED FOR 1-HR. OR 2-HR. FIRE-RATING, RESPECTIVELY.
7. MINIMUM 5/8" DEPTH HILTI FS-ONE MAX INTUMESCENT FIRESTOP SEALANT.
8. MINIMUM 1/2" BEAD HILTI FS-ONE MAX INTUMESCENT FIRESTOP SEALANT APPLIED AT POINT OF CONTACT.

NOTES : 1. WITH STEEL STUDS, MAXIMUM AREA OF SQUARE, RECTANGULAR, OR CIRCULAR OPENING IS 240 SQ. IN. WITH A MAXIMUM DIMENSION OF 20".

2. WITH WOOD STUDS, MAXIMUM AREA OF SQUARE, RECTANGULAR, OR CIRCULAR OPENING IS 210 SQ. IN. WITH A MAXIMUM DIMENSION OF 14-1/2".

3. ANNULAR SPACE BETWEEN PENETRANTS AND PERIPHERY OF OPENING = MINIMUM 0", MAXIMUM 20".

4. ANNULAR SPACE BETWEEN PENETRANTS = MINIMUM 1", MAXIMUM 20".

5. CLOSED PIPING SYSTEM ARE NOT APPLICABLE TO THE CANADIAN REQUIREMENTS.

6. ADDITIONAL STUD FRAMING MEMBERS (ITEM 1A) MAY BE USED AS AN ALTERNATIVE TO MINERAL WOOL BACKER OR USED IN COMBINATION WITH MINERAL WOOL BACKER.



HILTI, Inc.
Plano, Texas USA (800) 879-8000

Sheet	2 of 2
Scale	-
Date	May 19, 2017

Drawing No.
**WL
8079f**