

WALL TO WALL JOINT: GYPSUM WALL TO CONCRETE OR BLOCK WALL ASSEMBLY

ASSEMBLY RATING = 1-HR. OR 2-HR.
 L-RATING AT AMBIENT = LESS THAN 1 CFM / LIN FT
 L-RATING AT 400°F = LESS THAN 1 CFM / LIN FT

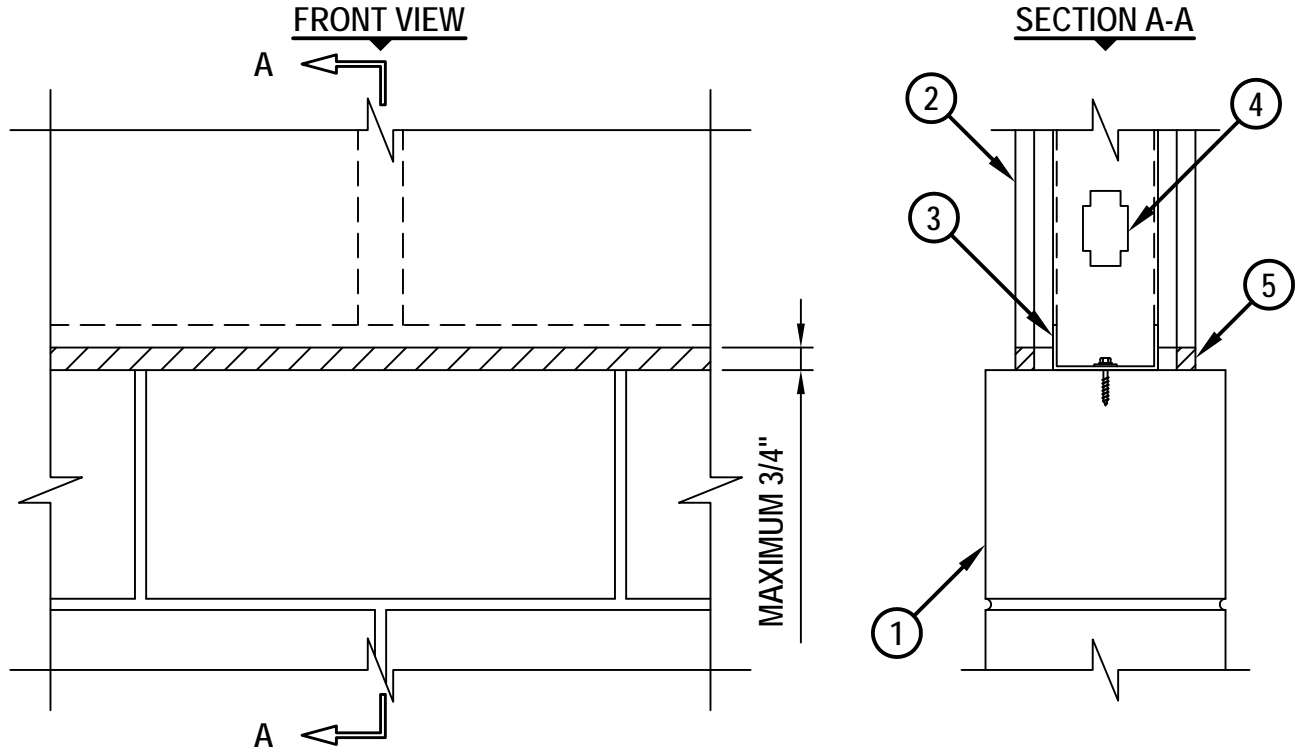

WWS0048d.111413

1. CONCRETE WALL ASSEMBLY :

- A. LIGHTWEIGHT OR NORMAL WEIGHT CONCRETE WALL (MINIMUM 4-3/4" THICK) (1-HR. FIRE-RATING).
- B. LIGHTWEIGHT OR NORMAL WEIGHT CONCRETE WALL (MINIMUM 6" THICK) (2-HR. FIRE-RATING).
- C. ANY UL/cUL CLASSIFIED CONCRETE BLOCK WALL (1-HR. OR 2-HR. FIRE-RATING). TOP COURSE OF CONCRETE BLOCKS SHOULD BE SOLID OR FILLED WITH CONCRETE.

2. GYPSUM WALL ASSEMBLY (UL/cUL CLASSIFIED U400, V400, OR W400 SERIES) (1-HR. OR 2-HR. FIRE-RATING) (2-HR. SHOWN).

- 3. FLOOR RUNNER (MINIMUM 25 GA., WITH MINIMUM 1-1/4" FLANGES) SECURED TO CONCRETE WALL ASSEMBLY WITH STEEL CONCRETE FASTENERS (SPACED MAXIMUM 24" C/C).
- 4. STEEL STUDS (MINIMUM 3-1/2" WIDE), CUT 1/2" TO 3/4" LESS IN LENGTH THAN ASSEMBLY HEIGHT, WITH BOTTOM NESTING IN, NESTING ON AND FASTENED TO FLOOR RUNNER (SPACED MAXIMUM 24" C/C).
- 5. MINIMUM 5/8" DEPTH HILTI CP 601S ELASTOMERIC FIRESTOP SEALANT, HILTI CP 606 FLEXIBLE FIRESTOP SEALANT, OR HILTI CFS-S SIL GG FIRESTOP SILICONE SEALANT.

NOTES : 1. [OPTIONAL, NOT SHOWN] MINERAL WOOL, FIBERGLASS, OR POLYURETHANE/POLYETHYLENE FOAM BACKER ROD MAY BE USED AS A BACKER IN 2-HR. WALLS.
 2. L-RATINGS ONLY APPLIES WHEN HILTI CP 606 FIRESTOP SEALANT OR HILTI CFS-S SIL GG FIRESTOP SILICONE SEALANT IS USED.



HILTI, Inc.
 Tulsa, Oklahoma USA (800) 879-8000

Sheet	1 of 1
Scale	5/32" = 1"
Date	Nov. 14, 2013

Drawing No.
WWS
0048d