



Classified by
Underwriters Laboratories, Inc.
to UL 2079 and CAN/ULC-S115

System No. HW-D-0970

HWD 0970

ANSI/UL2079	CAN/ULC S115
Assembly Ratings - 1 and 2 Hr (See Item 2)	F Ratings - 1 and 2 Hr (See Item 2)
Nominal Joint Width - 1 In.	FT Ratings - 1 and 2 Hr (See Item 2)
Class II Movement Capabilities – 12.5% Compression or Extension	FH Ratings - 1 and 2 Hr (See Item 2)
L Rating at Ambient – 1.1 CFM/Lin FT	FTH Ratings - 1 and 2 Hr (See Item 2)
L Rating at 400 F - Less Than 1 CFM/Lin FT	Nominal Joint Width – 25 mm
	Class II Movement Capabilities – 12.5% Compression or Extension
	L Rating at Ambient - Less Than 1.71 L/s/m
	L Rating at 204°C - Less Than 1.55 L/s/m

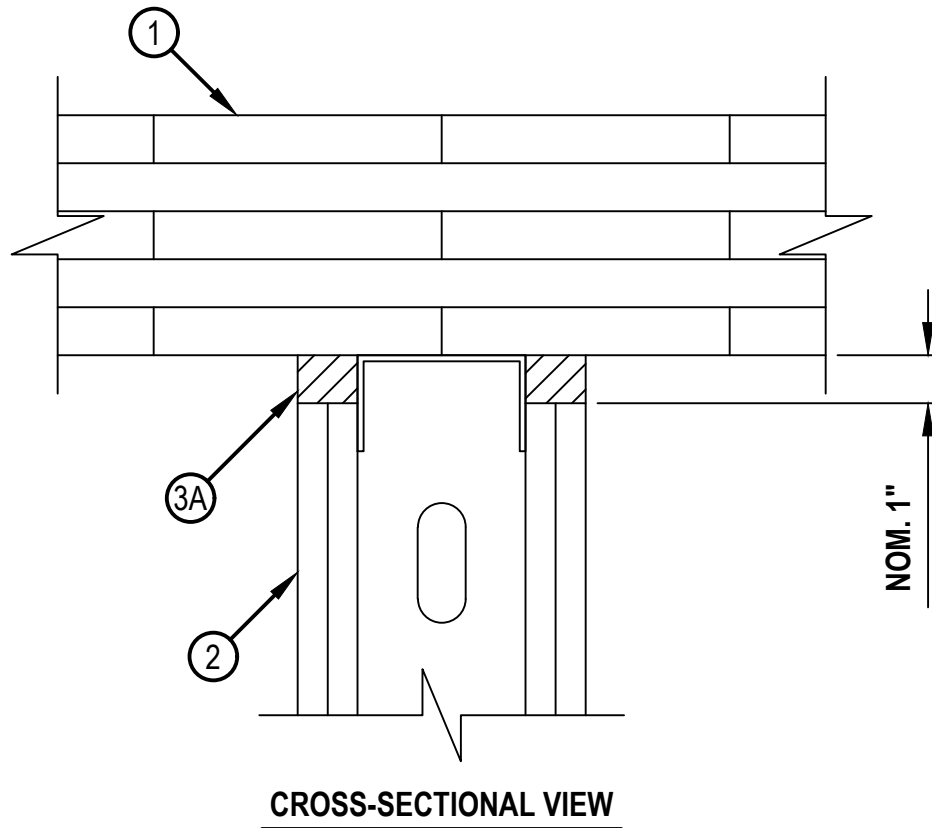

1. Floor Assembly —Mass Timber Floor — Min 5-1/8in. (130 mm) thick, 5 ply cross laminated timber (CLT) panel, labeled Grade CV3 in accordance with ANSI/APA PRG 320 as required by Chapter 6 of International Building Code (IBC) for Type IVA, IVB or IVC construction. The required hourly rating of the CLT floor shall be determined in accordance with Chapter 16 of the National Design Specification (NDS). Additional information regarding the use of CLT as permitted in the IBC is located in the XHEZ Guide Information. The indicated or calculated fire resistance rating of the assembly (Type IV A, B or C) to meet or exceed the assembly rating of the firestop system. The grains of the bottom ply on the CLT panel may be oriented perpendicular, parallel, or at any angle to the wall assembly.



Reproduced by HILTI, Inc. Courtesy of
Underwriters Laboratories, Inc.
December 5, 2023

2. Wall Assembly — The 1 or 2 hr fire rated gypsum board/steel stud wall assembly shall be constructed of the materials and in the manner specified in the individual U400, V400 or W400 Series Wall and Partition Design in the UL Fire Resistance Directory and shall include the following construction features:

A. Steel Floor and Ceiling Runners — Floor and ceiling runners of wall assembly shall consist of min No. 25 gauge galv steel channels sized to accommodate steel studs (Item 2B). Flange height of ceiling runner shall be min 1/4 in. (6 mm) greater than max extended joint width. Ceiling runner secured with min No. 10 by 1-1/2 in. (38 mm) long steel fasteners spaced 24 in. (610 mm) OC.

A1. Light Gauge Framing* — Slotted Ceiling Runner - As an alternate to the ceiling runner in Item 2A, slotted ceiling runner to consist of galv steel channel with slotted flanges sized to accommodate steel studs (Item 2B). Slotted ceiling runner secured to valleys lower surface of floor with min No. 10 by 1-1/2 in. (38 mm) long steel fasteners spaced max 24 in. (610 mm) OC.

CEMCO, LLC — CST

CLARKDIETRICH BUILDING SYSTEMS — Types SLT, SLT-H

MARINO/WARE, DIV OF WARE INDUSTRIES INC — Type SLT

METAL-LITE INC — The System

SCAFCO STEEL STUD MANUFACTURING CO — Slotted Track

TELLING INDUSTRIES L L C — True-Action Deflection Track

RAM SALES L L C — RAM Slotted Track

A2. Light Gauge Framing* - Vertical Deflection Ceiling Runner - As an alternate to the ceiling runners in Items 2A and 2A1, vertical deflection ceiling runner to consist of galv steel channel with slotted vertical deflection clips mechanically fastened within runner. Slotted clips provided with step bushings for permanent fastening of steel studs. Flanges sized to accommodate steel studs (Item 2B). Vertical deflection ceiling runner secured to lower surface of floor with steel fasteners spaced max 24 in. (610 mm) OC.

THE STEEL NETWORK INC — VertiTrack VTD250, VTD362, VTD400, VTD600 and VTD800

B. Studs — Steel studs to be min 3-1/2 in. (89 mm) wide. Studs cut 1/2 to 3/4 in. (13 to 19 mm) less in length than assembly height with bottom nesting in and resting on floor runner and with top nesting in ceiling runner without attachment. When slotted ceiling runner (Item 2A1) is used, steel studs secured to slotted ceiling runner with No. 8 by 1/2 in. (13 mm) long wafer head steel screws at mid-height of slot on each side of wall. Stud spacing not to exceed 24 in. (610 mm) OC. When vertical deflection ceiling runner (Item 2A2) is used, steel studs secured to slotted vertical deflection clips, through the bushings, with steel screws at mid-height of each slot. Stud spacing not to exceed 24 in. (610 mm) OC.

C. Gypsum Board* — One or two layers of 5/8 in. (16 mm) thick gypsum board for 1 and 2 hr rated assemblies, respectively, as required in the individual Wall and Partition Design. Wall to be constructed as specified in the individual U400 or V400 Series Design in the UL Fire Resistance Directory, except that a max 1 in. (25 mm) gap shall be maintained between the top of gypsum board and bottom of concrete floor for 1 and 2 hr rated assemblies. The screws attaching the gypsum board to the studs at the top of the first layer shall be located 7 in. (178 mm) below the floor. The screws attaching the second layer to the steel studs shall be installed into the studs 5 in. (127 mm) below the floor.

The hourly fire rating of the joint system is dependent on the hourly fire rating of the wall assembly in which it is installed.

3. Joint System — When max separation between bottom of floor and top of wall is 1 in. (25 mm). The joint system is designed to accommodate a max 12.5 percent compression or extension from its installed width. The joint system consists of the following:

A. Fill, Void or Cavity Material* — Sealant — Min 1-1/4 in. (32 mm) thickness of fill material flush with the surface of the gypsum board for 2 hr fire rated systems or 5/8 in. (16 mm) thickness of fill material for 1 hr fire rated systems installed on each side of the wall between the top of the gypsum board and the bottom of the mass timber floor.

HILTI CONSTRUCTION CHEMICALS, DIV OF HILTI INC — CP606 Flexible Firestop Sealant

* Indicates such products shall bear the UL or cUL Certification Mark for jurisdictions employing the UL or cUL Certification (such as Canada), respectively.

