

UL/cUL SYSTEM NO. WW-D-1129

FIRE-RATED JOINT THROUGH CONCRETE WALL ASSEMBLY

ASSEMBLY RATING = 2-HR.

L-RATING AT AMBIENT = LESS THAN 1 CFM / LIN FT

L-RATING AT 400°F = LESS THAN 1 CFM / LIN FT

CLASS II MOVEMENT CAPABILITIES - 33% COMPRESSION OR EXTENSION

WWD1129a.011714

FRONT VIEW

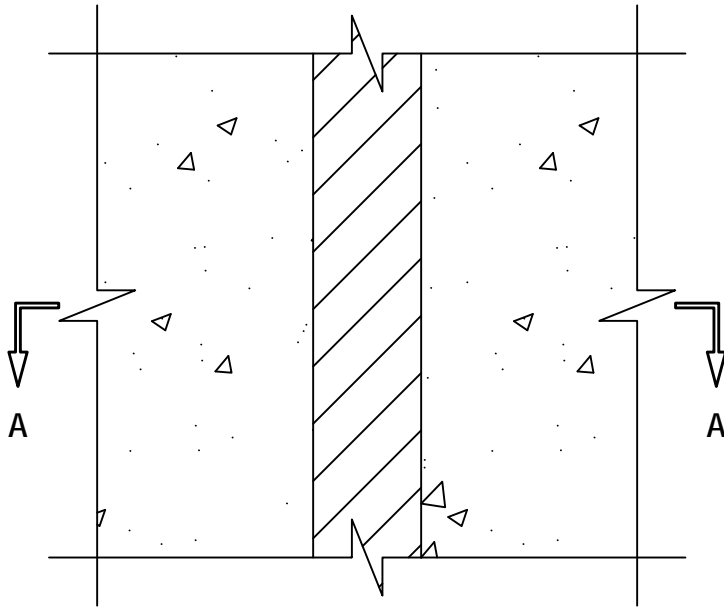

SECTION A-A

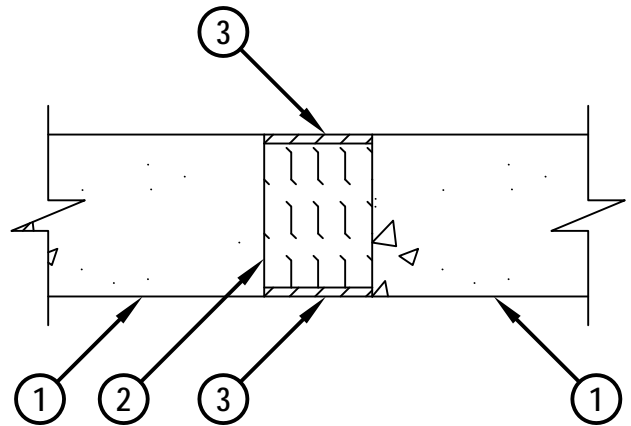

1. CONCRETE WALL ASSEMBLY (2-HR. FIRE-RATING) :
 - A. LIGHTWEIGHT OR NORMAL WEIGHT CONCRETE WALL (MINIMUM 4-1/2" THICK).
 - B. ANY UL/cUL CLASSIFIED CONCRETE BLOCK WALL.
2. MINIMUM 4" THICKNESS MINERAL WOOL SAFING (MIN. 4 PCF DENSITY) COMPRESSED 50% AND RECESSED FROM BOTH SURFACE OF WALL TO ACCOMMODATE FIRESTOP SEALANT.
3. MINIMUM 1/4" DEPTH HILTI CFS-S SIL GG FIRESTOP SILICONE SEALANT FLUSH WITH BOTH SURFACES OF WALL.

NOTE : MAXIMUM WIDTH OF JOINT = 3".



HILTI, Inc.
Tulsa, Oklahoma USA (800) 879-8000

Sheet	1 of 1
Scale	3/16" = 1"
Date	Jan. 17, 2014

Drawing No.
**WWD
1129a**

Saving Lives through Innovation and Education