

Design No. CEJ 310 P (HI/BP 105-02)
PERIMETER FIRE BARRIER SYSTEM

Hilti, Inc.
 ASTM E 2307

Table 1

	FIRESTOP JOINT SPRAY CFS-SP WB	SILICONE JOINT SPRAY CFS-SP SIL
F-RATING	1 3/4-HR.	1 3/4-HR.
T-RATING	1 1/4-HR.	1 1/4-HR.
APPLICATION THICKNESS	1/8" WET FILM (1/16" DRY)	2mm (0.079") WET FILM
CYCLING (%) HORIZONTAL VERTICAL SEE NOTE 1	± 11.25 ± 5	± 7.5 ± 5

L-Rating <1.0 SCFM/LF

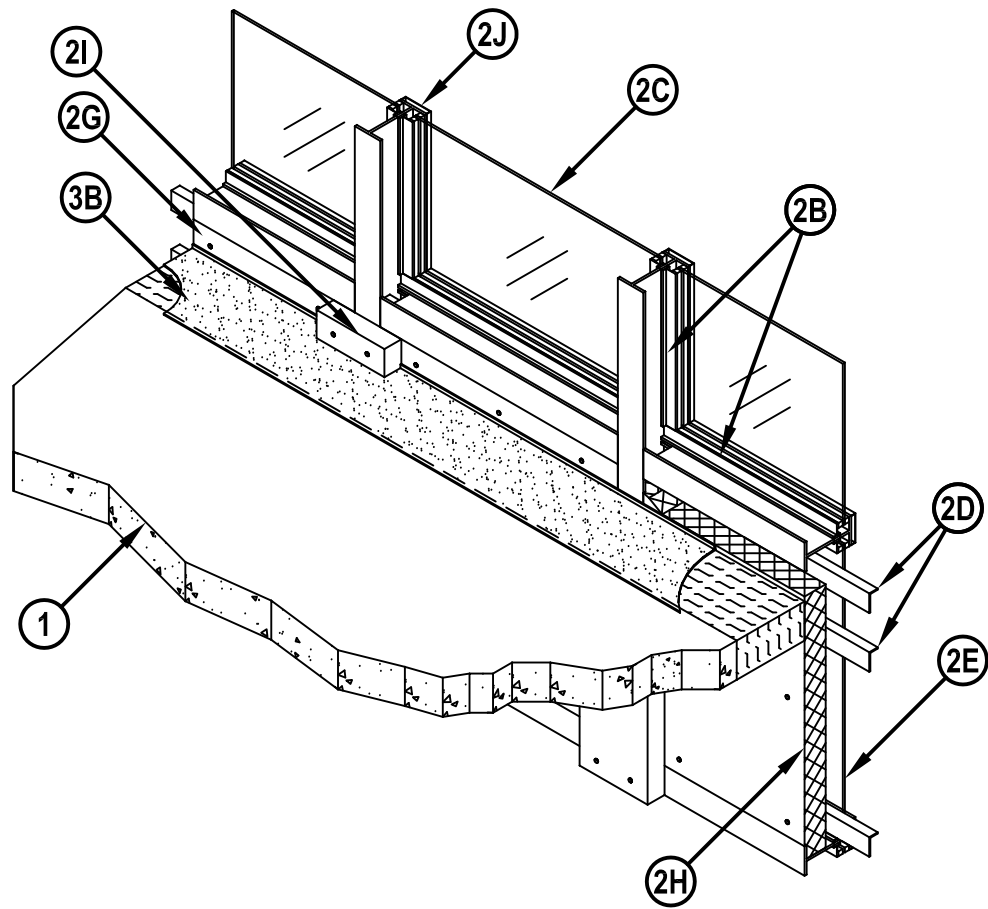

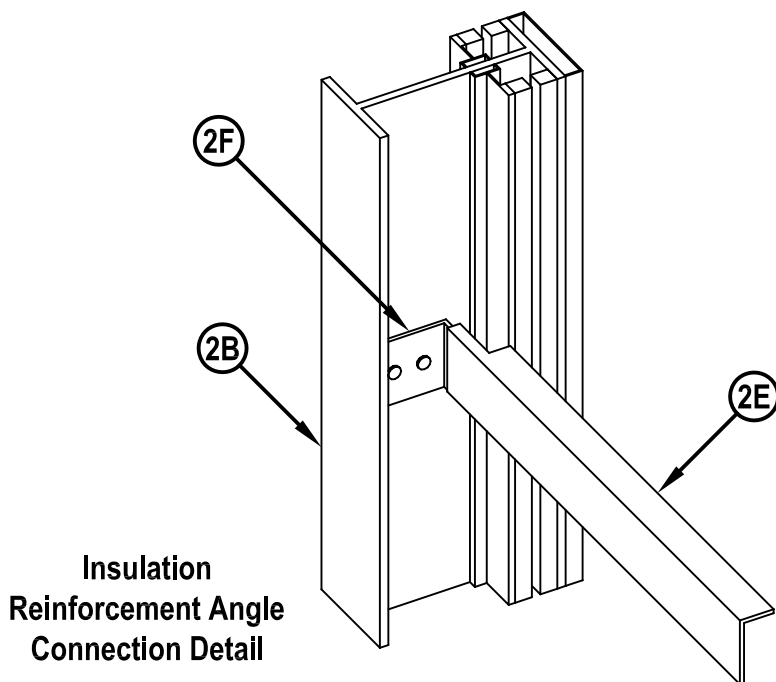

1. **CONCRETE FLOOR ASSEMBLY:** Three-hour rated concrete floor assembly made from either lightweight or normal weight concrete with a density of 100-150 pcf, with a min. thickness of 4 in. at the joint face. Overall slab thickness may vary to accommodate various blockout depths (longitudinal recesses) formed in the concrete, to house the architectural cover plate. The blockout width may also vary without restriction.

2. **CURTAIN WALL ASSEMBLY:** The curtain wall assembly shall incorporate the following construction features:

- A. **Mounting Attachment:** (Not shown) Attachment of the curtain wall framing to the structural framing shall be according to the curtain wall manufacturer's instructions to allow vertical shear movement only. When required, the mounting attachments to the floor slab shall be connected to the joint face of the floor slab, according to the curtain wall manufacturer's instructions. Max. distance between mounting attachments shall be 10 ft. One optional method is to use min. 8 in. wide by 3/4 in. thick extruded aluminum Halfen mullion mounting brackets with one nom. 2 in. high leg for support and attachment to the mullion and with one leg at least 6 in. longer than nominal joint width. Attach the mounting bracket to the top of the floor with two min 1/2 in. dia. steel masonry anchors in conjunction with washer plates supplied with the mounting brackets.
- B. **Aluminum Framing:** Install I shaped mullions and transoms, sized according to the curtain wall system manufacturer's guidelines. Min. overall dimensions of mullion framing is 0.125 in. thick with a min. 5-1/2 in. height and a min. of 2-1/2 in. width of the extrusion. Min. overall dimensions of transom framing is 0.125 in. thick with a min. 2 in. height and a min. of 2 in. width of the extrusion. Mullions are to be spaced a min. 56-1/2 in. on center (oc) and transoms are to be spaced a min. 31 in. oc For the spandrel region, the lower transom must be placed a min. of 21 in. below the concrete floor (as measured from the underside of the floor to the top side of the transom) and the upper transom must be placed a min. of 3 in. above the floor (as measured from the top surface of the floor to the underside of the transom) while maintaining the min. 33-1/2 in. spandrel height. One optional fastening method is to space the mullions as noted herein and secure the mullion mounting anchors (Item 2A) at each floor level in conjunction with extruded aluminum clips bolted to the sides of the mullions and designed to engage the vertical leg of the Halfen mullion mounting bracket in conjunction with an extruded aluminum hook/leveling connector.
- C. **Vision Glass Panels:** Glass panels shall be sized and attached to curtain wall framing according to the curtain wall system manufacturer's guidelines. Use a min. 1/4 in. thick, clear heat-strengthened (HS) glass or tempered glass with a max. width and height less than the aluminum framing oc spacing, which allows the glass to be secured between the notched shoulder of the aluminum framing and pressure bar. Panels are secured with a thermal break (rubber extrusion), pressure bar (aluminum extrusion), min. 1/4-20 x 5/8 in. long screws, and a snap face (aluminum extrusion).



Hilti Firestop Systems

Reproduced by HILTI, Inc.
Courtesy of Intertek Group
June 20, 2014



- D. Glass Spandrel Panels: Glass panels shall be sized and installed to curtain wall framing according to the curtain wall system manufacturer's guidelines. Use a min. 1/4 in. thick clear, heat-strengthened (HS) glass or tempered glass with a max. width and height less than the aluminum framing oc spacing, which allows the glass to be secured between the notched shoulder of the aluminum framing and pressure bar. Panels are secured with a thermal break (rubber extrusion), pressure bar (aluminum extrusion), min. 1/4-20 x 5/8 in. long screws, and a snap face (aluminum extrusion).
- E. Insulation Reinforcement Angle: Place min. 1 in. x 2 in. 20 GA galvanized steel angle horizontally in the spandrel area to reinforce the curtain wall insulation (2H). The 2 in. leg is placed flush against the exterior surface of the curtain wall insulation and the 1 in. dimension is positioned at the top of the 2 in. leg, perpendicular to and outward from the insulation as illustrated. Place a min. of 3 angles in each spandrel cavity between vertical framing members. Two angles are required to be spaced a max. 6 in. oc in the perimeter fire barrier region, with the top angle centered 1 in. above the floor. Outside of the perimeter fire barrier region, the spacing of these reinforcement angles is a max. 18 in. oc. On both ends of each angle, cut the 1 in. leg of the angle 2 in. from the end and fold down to form a slot that is slid onto the flange of the Clip Angle (2F).
- F. Clip Angles: Position min. 2 in. wide Clip Angles having 2 in. long flange dimensions, constructed of min. 18 GA. galvanized steel, onto the I-mullions at the required elevation locations of the Insulation Reinforcement Angles (2E). The Clip Angles are secured to the web of the I-mullion with a min. of two 1 in. No. 10 self-tapping sheet metal screws placed on the horizontal centerline of the flange adjacent to the I-mullion, 1/2 in. from each end.
- G. Insulation Retaining Screws: In the field of the curtain wall insulation between framing covers (2I) attach curtain wall insulation (2H) to the insulation reinforcement angle (2E) with min. 3 in. long No. 8 bugle head self-tapping screws fitted with min. 1-1/2 in. diameter steel clinch shields or self-locking washer clips. These are spaced a max. 12-3/4 in. oc and a max. 4 in. on each side of vertical seams. Where the framing covers (2I) overlap onto the curtain wall insulation (2H) secure framing covers (2I) and curtain wall insulation (2H) to the insulation reinforcement angle (2E) with min. 5 in. long No. 10 bugle head self-tapping screws and min. 1-1/2 in. diameter steel clinch shields or self-locking washer clips in accordance with details in 2I.
- H. Curtain Wall Insulation: A nom. 2 in. thick, 8pcf density mineral wool batt insulation**, faced on one side with aluminum foil scrim (vapor retarder) which faces the room interior, is installed to fill all cavities of the spandrel region between the framing. The batt is to be fitted tightly to the framing, and is secured to the Insulation Reinforcement Angle (2E) with Insulation Retaining Screws and min. 1-1/2 in. diameter steel clinch shields or self-locking washer clips. (2G). A min. 3 in. air space is created between the insulation and panel. All meeting edges of insulation are sealed with nom. 4 in. wide pressure sensitive aluminum foil faced tape centered over the junction so that approx. 2 in. of tape covers each edge of the adjacent insulation. The 36 in. wide batts shall be installed with no vertical seams. Horizontal seams must be spaced a min. of 3 in. above the perimeter fire barrier.
- I. Framing Covers: Strips made of 2 in. thick by 8 in. wide, 8 pcf, mineral wool batt insulation, faced one side with aluminum foil scrim (vapor retarder) which faces the room interior, are centered over each vertical framing member and secured to the Insulation Reinforcement Angle (2E) with Insulation Retaining Screws spaced 1 in. from both edges of the framing cover. Framing covers do not pass through the perimeter joint treatment. They are butted to the top and bottom surfaces of the perimeter joint treatment.
- J. Panel Attachment: Secure panels with a thermal break (thermal-set rubber extrusion), pressure bar (aluminum extrusion), 1/4-20 x 5/8 in. long screws, and a snap face (aluminum extrusion). The spandrel panels shall be insulated according to 2H.
3. PERIMETER JOINT PROTECTION: The perimeter joint (linear opening) shall not exceed an 8 in. nom. joint width (joint width at installation) and the perimeter joint treatment shall incorporate the following construction features:
- A. Packing Material: Use a min. 4 in. thick, 4 pcf density, mineral wool** batt insulation installed with the fibers running parallel to the slab edge and curtain wall. The packing material shall be compressed 44% in the nominal joint width. Compress the batt insulation into the perimeter joint such that the top surface of the batt insulation is flush with the top surface of the concrete floor slab. Splices (butt joints) in the lengths of mineral wool batt insulation are to be tightly compressed together with min. compression of 0.25 in. per piece. Reference the Introduction to Fire Resistive Joint Systems Section of this Directory for more details on how to determine the cut width of the insulation to be installed in the nominal joint width, and how to determine the compressed percentage of a known insulation width installed in a known nominal joint width.



Hilti Firestop Systems

Reproduced by HILTI, Inc.
Courtesy of Intertek Group
June 20, 2014



Design No. CEJ 310 P (HI/BP 105-02)

CEJ 310 P

B. CERTIFIED MANUFACTURER: Hilti, Inc.

CERTIFIED PRODUCT: Joint Spray or Sealant

MODEL: Firestop Joint Spray CFS-SP WB or Silicone Joint Spray CFS-SP SIL

Fill, Void or Cavity Material: To be applied (sprayed, brushed, or trowled) to cover the exposed surface of the mineral wool installed in the perimeter joint. Apply at the thickness specified in Table 1 and overlap the material a min. 1/2 in. onto the adjacent curtain wall assembly and concrete floor slab assembly. If the spraying process is stopped and the applied liquid cures to an elastomeric film before process is restarted, then overlap the edge of the cured material at least 1/8 in. with the spray. Reference Product Section of this Directory for more details about the Listed product.

Note 1 – Before testing, the spliced test specimen was cycled 500 times at 30 cpm according to ASTM E 1399 and ICBO ES AC 30 (Jan. 1997)

(**Product Certified by Intertek Testing Services bearing a WH Mark)

This Design Listing was created using the information outlined in the Introduction to the Fire-Resistant Joint Systems Section. Please refer to that Introduction to complement the Design Listing.



Hilti Firestop Systems

Reproduced by HILTI, Inc.
Courtesy of Intertek Group
June 20, 2014

