

Design No. CEJ 315 P (HI/BP 165-02)
PERIMETER FIRE BARRIER SYSTEM

Hilti, Inc.
 ASTM E 2307

Table 1

	FIRESTOP JOINT SPRAY CFS-SP WB	SILICONE JOINT SPRAY CFS-SP SIL
F-RATING	2 3/4-HR.	2 3/4-HR.
T-RATING	1-HR.	1-HR.
APPLICATION THICKNESS	1/8" WET FILM (1/16" DRY)	2mm (0.079") WET FILM
CYCLING (%) HORIZONTAL VERTICAL SEE NOTE 1	± 8.3 ± 5	± 7.5 ± 5

L-Rating <1.0 SCFM/LF

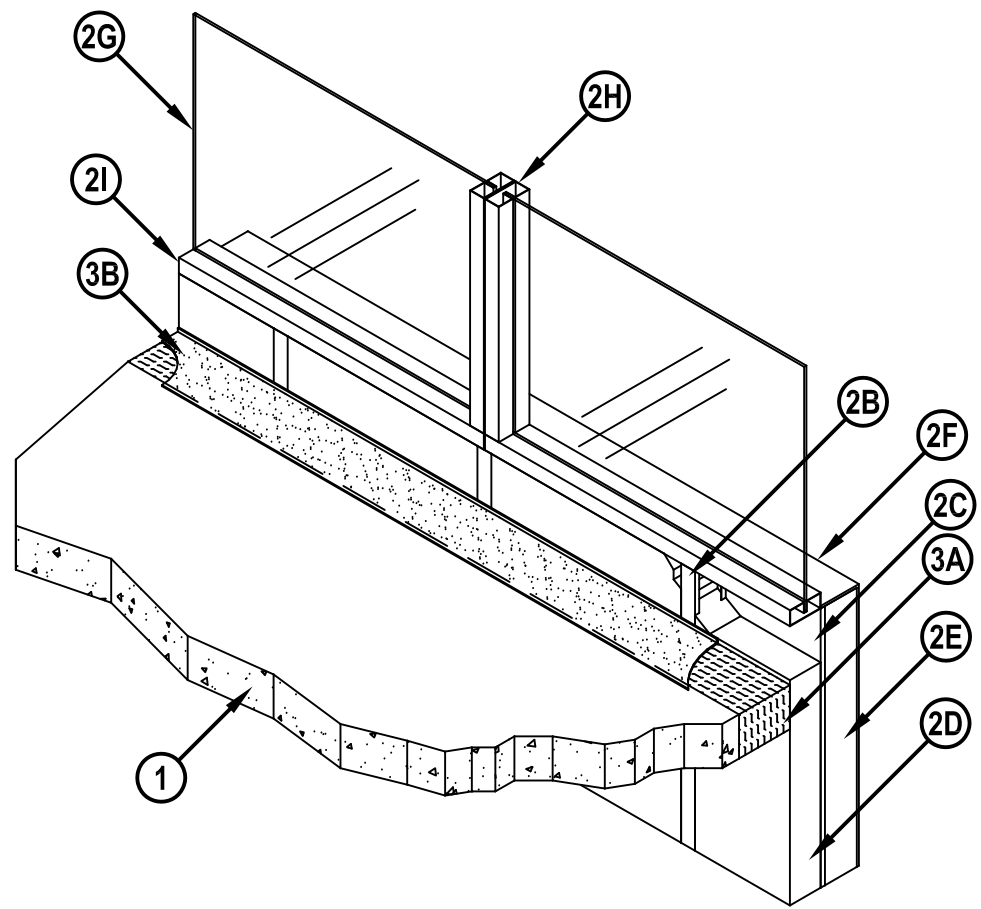

1. CONCRETE FLOOR ASSEMBLY: Max. two-hour rated concrete floor assembly made from either lightweight or normal weight concrete with a density of 100-150 pcf, with a min. thickness of 4-1/2 in. at the joint face. Overall slab thickness may vary to accommodate various blockout depths (longitudinal recesses) formed in the concrete, to house the architectural cover plate. The blockout width may also vary without restriction.
2. CURTAIN WALL ASSEMBLY: The curtain wall assembly shall incorporate the following construction features:
 - A. Mounting Attachment: (Not shown) Attachment of the curtain wall framing to the structural framing shall be according to the curtain wall manufacturer's instructions. When required, the mounting attachments to the floor slab shall be connected to the joint face of the floor slab, according to the curtain wall manufacturer's instructions. Max. distance between mounting attachments shall be 24 in.
 - B. Steel-Stud Framing: Vertical framing members shall be a min. 3-5/8 in. by 1-5/8 in., 18 GA steel "C" studs secured in an 18 GA steel track top and bottom using #6 x 1.25 in. Bugle head SD PT screws. Vertical framing shall not exceed a spacing of 24 in. on center (oc).
 - C. Sandwiched Wall Surface: Use a min. 1/2 in. thick, 48 in. wide by 96 in. long, exterior grade gypsum wallboard (ASTM C 79), cement board, or fiberglass sheathed gypsum wallboard placed over and secured to framing with min. 1-1/4 in. long Type S drywall screws 8 in. oc.
 - D. Curtain Wall Insulation: Use a nom. 24 in. wide by min. 4 in. thick min. 4 pcf faced or un-faced mineral wool** batt insulation cut to size as required. The curtain wall insulation shall completely fill the recess of the min. 3-5/8 in. by 1-5/8 in., by 18 GA steel "C" studs. If the stud cavity is deeper than 3-5/8 in, use thicker insulation to accommodate the additional depth so that the cavity is full from the front of the stud to the rear of the stud. Install curtain wall insulation in each stud cavity so that min. 6 in. of curtain wall insulation is above the surface of the perimeter joint protection and a min. of 6 in. is below the underside of the floor, while maintaining the min. 24 in. continuous vertical length of insulation in the spandrel region. The 24 in. width is fitted tightly between vertical framing members filling all studs in the spandrel region. Because the insulation is required to be continuous in both width and length, without butted joints, use of aluminum foil tape to seal between the insulation and the studs is optional. (** Listed with Intertek)
 - E. Exterior Curtain Wall Insulation: An Exterior Insulation Finish System (EIFS) is composed of expanded polystyrene foam (EPS) insulation, and an Exterior Curtain Wall Finish (2F). The EIFS system is a monolithic assembly without expansion or control joints. The EPS foam boards measure 24 in. wide by 48 in. long by 4 inches thick with a nominal density of 1 pcf. The EPS foam is attached to the sandwiched wall surface using mechanical fasteners or an adhesive in accordance with manufacturer's recommendations. Install the EPS boards in a running bond (brick-like) pattern and staggered over sandwiched wall surface (2C) joints. Apply pressure to the EPS boards to assist in the bonding process. All EPS boards must be butted together with no gaps or voids between them. Allow a min. of 12 hours before continuing the application process when using adhesive. The EPS boards must be rasped to remove all irregular seams and establish a continuous flat surface.
 - F. Exterior Curtain Wall Finish: The cementitious base coat and reinforcing mesh is applied over the Exterior Curtain Wall Insulation (2D). Precut the mesh as needed. The mesh is a woven fiberglass reinforcement fabric that is compatible with the cementitious base coat and finish coat materials. Apply 1/16 to 1/8 in. thick cementitious base coat to the exposed surface of the EPS foam. Apply the mesh; embed the mesh into the cementitious base coat using a trowel. Start at the middle and work outwards towards edges. The final thickness of the cementitious base coat with the mesh embedded should be approximately 1/16 in. Let the cementitious base coat dry completely before applying the cementitious finish coat. The cementitious finish coat is a cement based wall coating which may contain silica sand or marble aggregates. Apply the cementitious finish coat using a trowel in the same manner as the cementitious base coat.
 - G. Glass Vision Panels: Glass vision panels shall be installed to curtain wall framing according to the curtain wall system manufacturer's guidelines. Use a min. 1/4 in. thick, clear tempered glass that is fitted to the framing, having a min. width of 24 in. and min. height of 24 in.
 - H. Window Gaskets: Secure glass vision panels with a thermal break (thermal-set rubber extrusion).
 - I. Window Framing: Steel framing members shall be a min. 3-5/8 in. by 1-5/8 in. 18 GA steel "U" channel or similar construction that is compatible with steel-stud framing (2B). Locate window framing at least 6 inches above the top surface of the floor assembly.



3. PERIMETER JOINT PROTECTION: The perimeter joint (linear opening) shall not exceed a 6 in. nom. Joint width (joint width at installation) and the perimeter joint treatment shall incorporate the following construction features:

A. Packing Material: Use a min. 4 in. thick, 4 pcf density, mineral wool batt insulation** installed with the fibers running parallel to the slab edge and curtain wall. The packing material shall be compressed 25% in the nominal joint width. Compress the batt insulation into the perimeter joint such that the top surface of the batt insulation is flush with the top surface of the concrete floor slab and the insulation is compressed against the interior surface of the curtain wall insulation (2D). Splices (butt joints) in the lengths of mineral wool batt insulation are to be tightly compressed together. Reference the Introduction to Fire Resistive Joint Systems Section of this Directory for more details on how to determine the cut width of the insulation to be installed in the nominal joint width, and how to determine the compressed percentage of a known insulation width installed in a known nominal joint width. (** Listed with Intertek)

B. CERTIFIED MANUFACTURER: Hilti, Inc.

CERTIFIED PRODUCT: Joint Spray or Sealant

MODEL: Firestop Joint Spray CFS-SP WB or Silicone Joint Spray CFS-SP SIL

Fill, Void or Cavity Material: To be applied (sprayed, Brushed, or painted) to cover the exposed surface of the mineral wool installed in the perimeter joint. Apply at the thickness specified in Table 1 and overlap the material a min. 1/2 in. onto with Curtain Wall Insulation (2D) and Concrete Floor Assembly (1). If the spraying process is stopped and the applied liquid cures to an elastomeric film before process is restarted, then overlap the edge of the cured material at least 1/8 in. with the spray. Reference Product Section of this Directory for more details about the Listed product.

**Before testing, the spliced test specimen was cycled 500 times at 30 cpm according to ASTM E 1399 and ICBO ES AC 30 (Jan. 1997).



Hilti Firestop Systems

Reproduced by HILTI, Inc.
Courtesy of Intertek Group
June 20, 2014

