



Classified by
Underwriters Laboratories, Inc.
to UL 1479

System No. F-B-2056

F Rating — 2 Hr

T Rating — 0 Hr

FB 2056

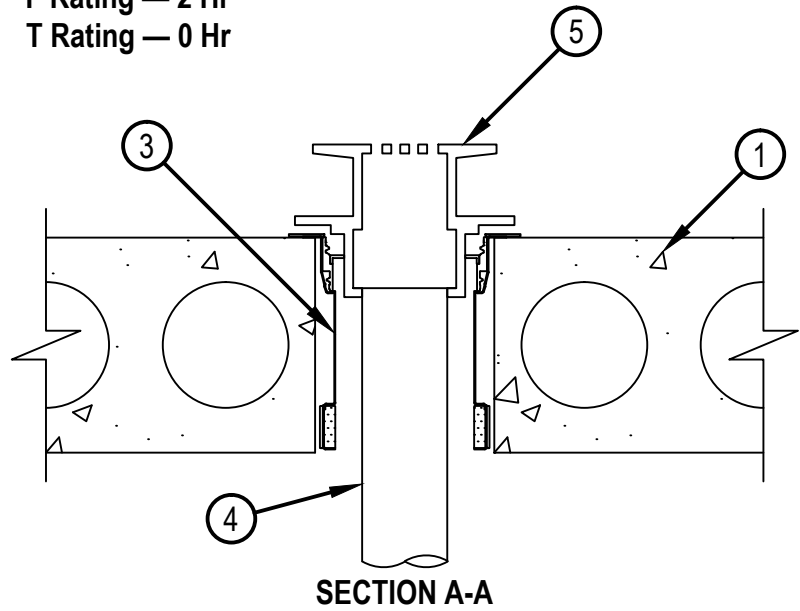
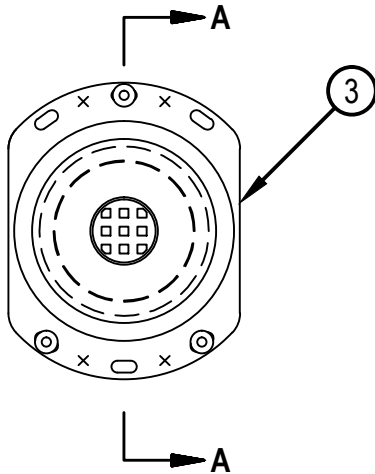

1. Floor Assembly — Min 6 in. (127 mm) to max 12 in. (305 mm) thick lightweight or normal weight (100-150 pcf or 1600-2400 kg/m³) concrete floor assembly, or min 6 in. (127 mm) to max 12-1/2 in. (318 mm) thick hollow core Precast Concrete Units*. Diam of opening is 5 in. (127 mm). See Precast Concrete Units (CFTV) categories in the Fire Resistance Directory for names of manufacturers.
2. Sheet Metal Sleeve — (Optional, Not Shown) - Nom 5 in. (127 mm) diam, min 26 ga galv steel and having a min 2 in. (51 mm) lap along the longitudinal seam, and may extend a max of 4 in. (102 mm) below the bottom of the floor and flush with the top surface of the concrete floor. Sleeve installed by coiling the sheet steel to a diam smaller than the through opening, inserting the coil through the openings and releasing the coil to let it uncoil against the opening.
- 2A. Metallic Sleeve — (Optional, Not Shown) - In concrete floors, nom 5 in. (127 mm) diam Schedule 10 (or heavier) steel sleeve cast or grouted into floor assembly, flush with floor surfaces.
3. Firestop Device* — Drop-in firestop device installed in core-drilled or sleeved opening in concrete floor assembly in accordance with accompanying installation instructions. In hollow core floors, the firestop device shall extend a max 1/2 in. (13 mm) below the bottom surface of the floor or may be recessed a max of 1/2 in. from the bottom surface of the floor. The firestop device flange should be secured to the top surface of the floor with three 1/4 in. (6 mm) diam by min 1-1/4 in. (32 mm) long steel expansion bolts or screw anchors (installed in a triangular fashion through holes provided). As alternates to the anchors specified above, Hilti 1/4 in. (6 mm) diam by 1-1/4 in. (32 mm) long KWIK-CON II+ concrete screw anchor, Hilti 1/4 in. (6 mm) diam by 1-3/4 in. (45 mm) long KWIK-BOLT 3 steel expansion anchor or Hilti 1/4 in. (6 mm) by 3/4 in. (19 mm) long Metal HIT Anchor may be used. In addition, four 11/16 in. (18 mm) long Hilti X-GH P18 MX steel fasteners may be installed through the steel flange, two on each side. For hollow core floors, the firestop devices shall be installed as detailed in the following table:

Core Hole or Sleeve Diam, In. (mm)	Firestop Device	Nom Diam of Drain Pipe, In. (mm)	Min-Max Floor Thickness In. (mm)
5 (102)	CFS-DID 3"C	2 (51)	6 - 6-1/2 (152 - 165)
5 (102)	CFS-DID 3" HC8	2 (51)	7-1/2 - 8-1/2 (191 - 216)
5 (102)	CFS-DID 3" HC10	2 (51)	9-1/2 - 10-1/2 (241 - 267)
5 (102)	CFS-DID 3" HC12	2 (51)	11-1/2 - 12-1/2 (292 - 318)

HILTI CONSTRUCTION CHEMICALS, DIV OF HILTI INC — CFS-DID 3"C, CFS-DID 3"HC

4. Drain Piping — Nom 2 in. (51 mm) diam Schedule 40 solid core or cellular core Polyvinyl Chloride (PVC) drain piping cemented into bottom of shower/floor drain. Drain piping rigidly supported at underside of floor with suitable hangers.
5. Shower/Floor Drain Fitting — Polyvinyl chloride (PVC) shower fitting with chromed steel shower drain or floor drain strainer sized to accommodate drain pipe. PVC body cemented to nonmetallic drain pipe (Item 4).

*Bearing the UL Classification Mark



Hilti Firestop Systems

Reproduced by HILTI, Inc. Courtesy of
Underwriters Laboratories, Inc.
April 14, 2014