



Classified by
Underwriters Laboratories, Inc.
to UL 1479 and CAN/ULC-S115

System No. F-A-1051

F Rating - 2 Hr
T Rating - 0 Hr

FA 1051

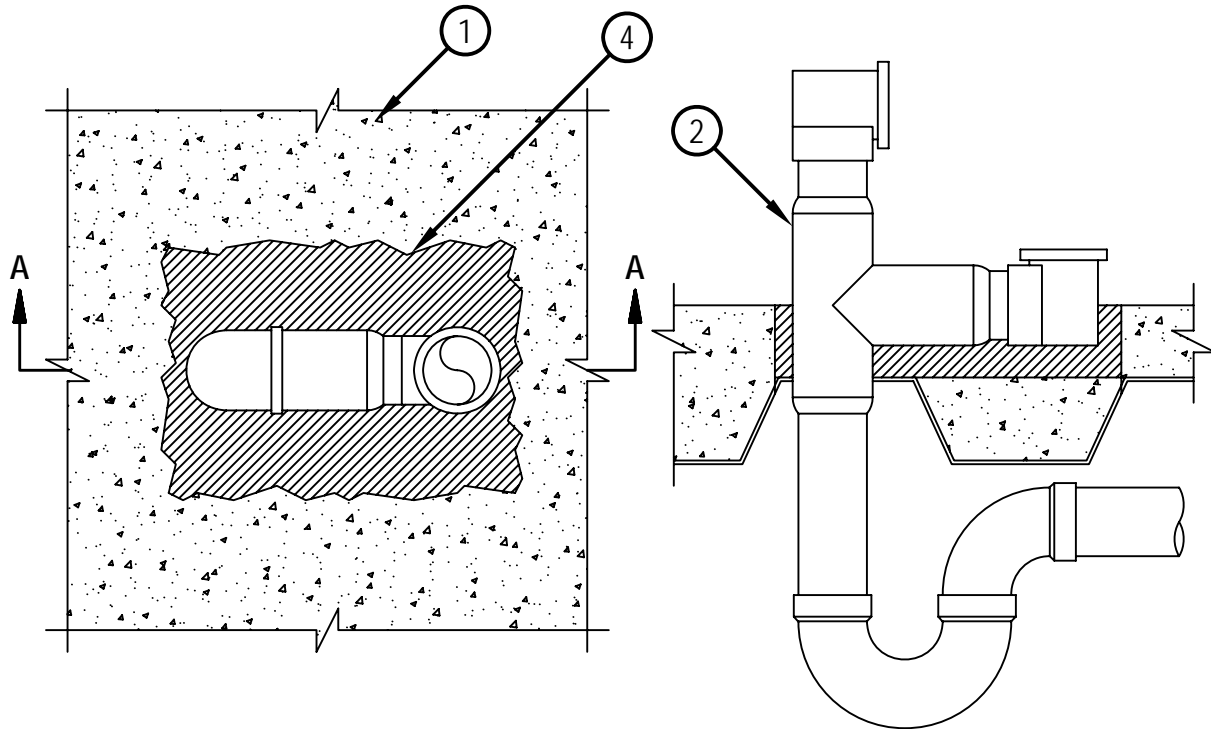

SECTION A-A

1. Floor Assembly -- The fire rated unprotected concrete and steel floor assembly shall be constructed of the materials and in the manner specified in the individual D900 Series designs in the UL Fire Resistance Directory and as summarized below:

- A. Concrete -- Min 2-1/2 in. thick reinforced lightweight or normal weight (100-150 pcf) concrete. Concrete to be recessed around opening to a depth of 2-1/2 in. Size of recess in concrete to be 102 sq in. with max dimension of 12 in.
- B. Steel Floor and Form Units* -- Composite or non-composite max 3 in. deep galv steel fluted units as specified in the individual Floor-Ceiling Design. Max diam of cored opening in steel deck is 4 in.

2. Waste/Overflow/Drain Fitting -- Nom 2 in. diam copper, brass or cast iron waste/overflow/drain fitting installed concentrically or eccentrically through cored opening. Piping system to be rigidly supported on both sides of floor-ceiling assembly. The annular space between piping system and periphery of cored opening shall be min of 0 in. (point contact) to max 1-7/8 in.

3. Forms -- (Not Shown) Used as a form to prevent leakage of fill material during installation. Forms to be rigid sheet material, cut to fit the contour of the penetrating item and positioned beneath steel deck as required to accommodate the required thickness of fill material. Forms may be removed after fill material has cured.

4. Fill, Void or Cavity Materials* - Mortar -- Min 2-1/2 in. thickness of fill material applied within annulus, flush with top surface of floor. Fill material is mixed at a rate of 2-1/2 parts dry mix to one part water by volume in accordance with the fill manufacturer's installation instructions.

HILTI CONSTRUCTION CHEMICALS, DIV OF
HILTI INC -- CP 637 Firestop Mortar

*Bearing the UL Classification Mark



Hilti Firestop Systems

Reproduced by HILTI, Inc. Courtesy of
Underwriters Laboratories, Inc.
March 19, 2003