



DIVISION: 05 00 00—METALS
Section: 05 05 23—Metal Fastenings
Section: 05 31 00—Steel Decking
REPORT HOLDER:

HILTI, INC.

EVALUATION SUBJECT:

STEEL DECK DIAPHRAGMS ATTACHED WITH HILTI X-HSN 24 OR X-ENP-19 L15 POWDER-DRIVEN FRAME FASTENERS AND HILTI S-SLC 01 M HWH OR S-SLC 02 M HWH SIDELAP CONNECTORS, OR VERCO DECKING VSC2 SIDELAP CONNECTION

1.0 EVALUATION SCOPE

Compliance with the following codes:

- 2021, 2018, 2015 and 2012 *International Building Code*® (IBC)

For evaluation for compliance with codes adopted by the Los Angeles Department of Building and Safety (LADBS), see [ESR-2776 LABC and LARC Supplement](#).

Property evaluated:

Structural

2.0 USES

Hilti's X-HSN 24 and X-ENP-19 L15 powder-driven frame fasteners; Hilti's S-SLC 01 M HWH and S-SLC 02 M HWH sidelap connectors; and Verco's VSC2 sidelap connections are used for the connection of steel deck diaphragms. The powder-driven fasteners are used to attach the steel deck panels to supporting steel framing, and the sidelap connectors/connections are used to connect the steel deck panels together at the panel sidelaps.

3.0 DESCRIPTION

3.1 Hilti Powder-Driven Frame Fasteners:

The Hilti powder-driven fasteners are manufactured from hardened carbon steel with an electroplated zinc coating complying with ASTM B633, SC 1, Type III. Table 1 and Figures 1 and 2 provide illustrations and additional information on the fasteners. Table 1 also provides depictions of the Hilti powder-driven fasteners and the corresponding steel support framing application ranges.

The X-HSN 24 fasteners are 0.960 inch (24.4 mm) long, with a 0.157-inch-diameter (4.0 mm), fully knurled tip and tapered shank. The X-HSN 24 fasteners have a dome-style head and a premounted 0.472-inch-diameter (12 mm) steel top hat washer with red plastic collation strip.

The X-ENP-19 L15 fasteners are 0.937 inch (23.8 mm) long with a 0.177-inch-diameter (4.5 mm) fully knurled tip and tapered shank fitted with two 0.590-inch-diameter (15 mm) steel cupped washers.

The Hilti SDK2 sealing cap is made from SAE 316 stainless steel with a neoprene washer and is intended to be installed over the flattened head of the X-ENP-19 L15 fastener. Figure 5 depicts the Hilti SDK2 sealing cap.

3.2 Sidelap Connectors / Connections:

3.2.1 Hilti Sidelap Connectors (SLC): The Hilti S-SLC 01 M HWH sidelap connectors are proprietary No. 10, double-thread, self-piercing, carbon steel threaded fasteners with an electroplated zinc coating, Cr3+ passivation.

The Hilti S-SLC 02 M HWH sidelap connectors are proprietary No. 12, single thread, self-drilling, carbon steel threaded fasteners with an electroplated zinc coating complying with ASTM F1941. Table 2 provides illustrations and corresponding steel material application limits.

3.2.2 Verco Sidelap Connections (VSC2): The VSC2 Connection is an interlocking connection between the male and female lips of the Verco PLB steel roof deck panels. A VSC2 connection is made in either direction relative to the female lip. A VSC2 Connection is made when the sidelap material has been sheared and offset so the sheared surface of the steel deck panel male leg is visible. The punched portion measures a minimum 0.45-inch nominal width by 0.30-inch nominal height. The resulting VSC2 Connection is illustrated in Figure 4e.

3.3 Steel Deck Panels:

The steel deck panels must be Type B (nestable), Type BI (interlocking) or Verco PLB (interlocking) steel deck panels complying with Table 3.

Type B and Type BI panels must comply with ASTM A653 SS Grade 33 (minimum) with a minimum G60 galvanized coating designation, or be phosphatized steel complying with ASTM A1008 SS Grade 33 (minimum). Steel deck panels may also be produced from ASTM A653 SS Grade 80 steel with a minimum G60 galvanized coating designation, except the minimum tensile strength must be 92 ksi (634 MPa).

Verco's PLB panels must comply with ASTM A653 SS Grade 50 Classes 1, 3, or 4 (minimum) steel, with a minimum G30 galvanized coating designation, or be phosphatized/painted, painted/painted, or mill-finished steel complying with ASTM A1008 Grade SS Grade 50 (minimum).

3.4 Steel Support Framing:

Structural steel supports of the steel deck panels (such as bar joists and structural steel shapes) must be manufactured from a code-compliant steel having minimum strength requirements of ASTM A36 and minimum thicknesses as noted in the tables of this report. Table 10 provides pullout values for fasteners installed into framing manufactured from code-compliant steel having minimum strength requirements of ASTM A572 Grade 50 or ASTM A992, in addition to pullout values for fasteners installed into code-compliant steel having minimum strength requirements of ASTM A36.

4.0 DESIGN AND INSTALLATION

4.1 Design:

For symbols and definitions, see the American Iron and Steel Institute's North American Standard for the Design of Profiled Steel Diaphragm Panels (AISI S310-20 w/S1-22)

4.1.1 Diaphragm Shear and Stiffness by Calculations:

The allowable (ASD) or factored (LRFD) diaphragm shear strength and stiffness must be determined in accordance with AISI S310-20 w/S1-22 while using Tables 4, 5, 6, and 8. The diaphragm shear strength must also be multiplied by the correlation factors in Table 5. The allowable (ASD) or factored (LRFD) diaphragm shear strength must not be greater than the allowable (ASD) or factored (LRFD) diaphragm buckling strengths in Table 9.

Minimum sidelap spacing of fasteners noted in Table 7 must be considered.

An example calculation can be found at the end of this report.

4.1.2 Uplift/Tension: For designs considering uplift/tension forces, see Tables 10 and 11.

4.2 Installation:

The B and BI decks are fastened to the structural supports with the Hilti powder-driven frame fasteners X-HSN 24 or X-ENP-19 in accordance with Table 1 and the sidelaps are connected with either the Hilti S-SLC 01 or S-SLC-02 in accordance with Table 2.

The Verco PLB deck is fastened to the structural supports with the Hilti powder-driven X-HSN 24 or X-ENP-19 frame fasteners in accordance with Table 1 and the sidelaps are connected with Verco's VSC2 Connection in accordance with Table 2.

The Hilti frame fasteners, Hilti sidelap connectors, Verco sidelap connections, and the Hilti SDK2 Sealing Caps must be installed in accordance with the manufacturer's published installation instructions.

Steel deck panel ends must overlap a minimum of 2 inches (51 mm) as shown in Figure 4b. End lap and corner lap conditions of two- and four-deck layers must be snug and tight to one another and the supporting steel frame, prior to frame fastener attachment. Standing seam interlocking-type sidelaps must be well engaged prior to sidelap connector installation.

Powder-driven frame fasteners must be installed in the specified pattern, and sidelap connectors must be installed at the specified spacing (see Figure 6a) or number of connectors per span (see Figure 6b). For conversion of specified fastener spacing to the number of sidelap fasteners to be installed, see Table 12. The powder-driven frame fastener patterns are shown in Figure 3. Figure 4 shows typical frame and sidelap connector connections details. Figure 7 provides an overview of the steel deck fastening systems recognized in this report.

5.0 CONDITIONS OF USE

Steel deck diaphragms comprised of steel deck panels attached to steel supports with Hilti X-HSN 24, or X-ENP-19 L15 powder-driven fasteners, with Hilti S-SLC 01 M HWH or Hilti S-SLC 02 M HWH sidelap connectors, or Verco's VSC2 sidelap connection, as described in this report, comply with, or are suitable alternatives to what is specified in, those codes listed in Section 1.0 of this report, subject to the following conditions:

- 5.1 The fasteners are manufactured, identified and installed in accordance with this report, the manufacturer's instructions and the approved plans. If there is a conflict, this report governs.
- 5.2 Steel deck panels must comply with this report. When the steel deck panels are used as roof decks, the panel must be covered with an approved code-complying roof covering.
- 5.3 No adjustment for duration of load is permitted.
- 5.4 Steel deck diaphragms may be zoned by varying steel deck panel gage and/or connections across a diaphragm to meet varying shear and flexibility demands.
- 5.5 For intermediate steel deck panel thicknesses or panel steel strengths, diaphragm strength and stiffness values shall be based on straight-line interpolation between values determined in accordance with Section 4.1, as described in the note at the end of the diaphragm design example shown in Figure 8.
- 5.6 The design of the steel deck panels for vertical loads is outside the scope of this report.
- 5.7 Calculations demonstrating compliance with this report must be submitted to the code official for approval. The calculations must be prepared by a registered design professional where required by the statutes of the jurisdiction in which the project is to be constructed.
- 5.8 Hilti fasteners may be used for attachment of steel deck roof systems temporarily exposed to the exterior during construction prior to application of built-up roof covering systems. The fasteners on permanently exposed steel deck roof coverings must be covered with a corrosion-resistant paint or sealant. As an alternate to applying a corrosion-resistant paint or sealant to the Hilti X-ENP-19 L15 fasteners, these fasteners may be used in conjunction with the SDK2 Stainless Steel Sealing Caps, described in Section 3.1 of this report, on permanently exposed steel deck roof coverings. For permanently exposed steel deck roof covering installations, the roof covering system's compliance with Chapter 15 of the code must be justified to the satisfaction of the code official.

6.0 EVIDENCE SUBMITTED

- 6.1 Data in accordance with the ICC-ES Acceptance Criteria for Steel Deck Roof and Floor Systems (AC43), dated June 2022.
- 6.2 Data in accordance with the ICC-ES Acceptance Criteria for Power-Actuated Fasteners Driven into Concrete, Steel and Masonry Elements (AC70), dated December 2019 (editorially revised January 2021).

7.0 IDENTIFICATION

- 7.1 All Hilti powder-driven fasteners and sidelap connectors described in this report are identified by an "H" stamped on the fastener head. All fasteners are packaged in containers noting the product designation, the company name of Hilti, Inc. and the evaluation report number (ESR-2776).

7.2 The report holder's contact information is the following:

HILTI, INC.
7250 DALLAS PARKWAY, SUITE 1000
PLANO, TEXAS 75024
(800) 879-8000
www.hilti.com/decking

TABLE 1—HILTI POWDER-DRIVEN FRAME FASTENER SELECTOR GUIDE¹

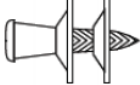
Steel Support Framing ²	Fastener Type
Bar Joist or Structural Steel Shape with $\frac{1}{8}$ in. $\leq t_f \leq \frac{3}{8}$ in.	 X-HSN 24
Structural Steel, Hardened Structural Steel or Heavy Bar Joist with $t_f \geq \frac{1}{4}$ in.	 X-ENP-19 L15 ³



For **SI**: 1 inch = 25.4 mm, 1 ksi = 6.89 Mpa.

¹Figure 7 illustrates an overview of the steel deck fastening systems recognized in this report and a visual representation of location for intended use on the steel deck diaphragm.

²The tensile strength (F_u) of the steel of the support framing must be less than 91 ksi for all fasteners and support framing steel thickness combinations, except for the X-HSN 24 fasteners with steel thicknesses greater than $\frac{5}{16}$ -inch. In this case, the tensile strength of the steel of the support framing must be less than 75 ksi for the X-HSN 24. For minimum strength requirements of the steel support framing, see Section 3.4 of this report.

³Reference Figure 5 for information regarding the use of the SDK2 sealing cap.

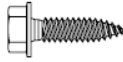
TABLE 2—SIDELAP CONNECTOR SELECTOR GUIDE¹

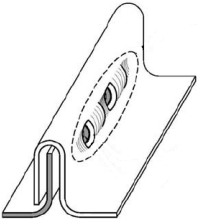
Steel Deck Panel Thicknesses	Fastener Type
Nos. 22, 20, 18 gage B and BI decks	 Hilti S-SLC 01 M HWH
Nos. 22, 20, 18, 16 gage B and BI decks	 Hilti S-SLC 02 M HWH
Nos. 22, 20, 18, 16 gage Verco PLB Deck	 Verco's VSC 2 Connection, See Figure 4e.

¹Figure 7 illustrates an overview of the steel deck fastening systems recognized in this report and a visual representation of location for intended use on the steel deck diaphragm.

TABLE 3—STEEL DECK PANEL SELECTOR GUIDE^{1,2,3}

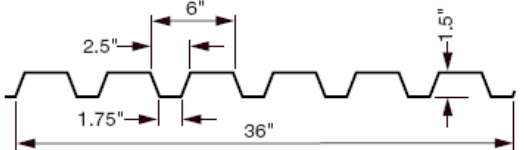
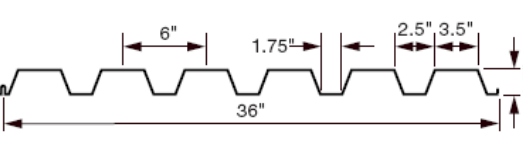
Deck Type	Nominal Dimensions	Deck Type	Nominal Dimensions
B-Deck		BI-Deck and Vercor PLB Deck	

¹B-Deck (nestable) and BI-Deck (interlocking) deck panel thicknesses must be 16, 18, 20 or 22 gage steel [(54, 43, 33 or 27 mil designations) (0.0598, 0.0474, 0.0358 or 0.0295 inch) (1.51, 1.21, 0.91 or 0.76 mm)], respectively. Intermediate steel deck panel thicknesses may be used (Reference Section 5.6 of this report).

²PLB (interlocking) deck panel thicknesses must be 16, 18, 20 or 22 gage steel [(54, 43, 33 or 27 mil designations) (0.0598, 0.0478, 0.0359 or 0.0299 inch) (1.51, 1.21, 0.91 or 0.76 mm)], respectively. Intermediate steel deck panel thicknesses may be used (Reference Section 5.6 of this report).

³BI-Deck (interlocking) deck panels must have screwable sidelap edges for use with Hilti SLC fasteners.

TABLE 4—DIAPHRAGM STRENGTH (S) AND DIAPHRAGM STIFFNESS (G') EQUATION VARIABLE VALUES (to be used with equations in AISI S310, Sections D1, D2 and D5.1)

Deck Type ¹	Frame Fastener Pattern ²	α_1 or α_3 – end distribution factor	α_2 or α_4 – purlin distribution factor	Σx_{ee}^2 or Σx_{ep}^2 , in. ²	Σx_{pe}^2 or Σx_{pp}^2 , in. ²	s/d	A	N per ft.	D_n – Warping Factor, in.			
									No. 22 gage	No. 20 gage	No. 18 gage	No. 16 gage
B- or BI-Deck	36/11	3.667	3.667	1,944	1,944	1.365	2	3.000	1,235	924	606	428
	36/9	3.000	3.000	1,656	1,656	1.365	2	2.333	1,235	924	606	428
	36/7	2.000	2.000	1,008	1,008	1.365	1	2.000	1,235	924	606	428
	36/5	1.667	1.667	936	936	1.365	1	1.333	7,288	5,452	3,578	2,525
	36/4	1.333	1.333	720	720	1.365	1	1.000	10,315	7,715	5,064	3,574
	36/3	1.000	1.000	648	648	1.365	1	0.667	21,217	15,871	10,417	7,315
Vercor PLB Deck	36/11	3.667	3.667	1,944	1,944	1.365	2	3.667	1,235	924	606	428
	36/9	3.000	3.000	1,656	1,656	1.365	2	3.000	1,235	924	606	428
	36/8	2.333	2.333	1,152	1,152	1.365	2	2.667	2,263	2,065	1,790	1,600
	36/7	2.000	2.000	1,008	1,008	1.365	1	2.333	1,235	924	606	428
	36/6	1.500	1.500	684	684	1.365	1	2.000	1,992	1,818	1,576	1,409

For SI: 1 inch = 25.4 mm, 1 in.² = 645 mm², 1 ft⁻¹ = 3.28m⁻¹.

¹See Table 3 for applicable steel deck panels.

²See Figure 3a and 3b for frame fastener patterns.

TABLE 5—DIAPHRAGM STRENGTH EQUATION VARIABLE VALUES

Configuration				Steel Deck Panel Gage Thickness							
				No. 22		No. 20		No. 18		No. 16 ³	
Deck Type	Minimum Deck Tensile, F _u , (Yield, F _y) Strengths, ksi	Frame Fastener/ Steel Support Framing Thickness, in.	Sidelap Connector ^{1,2}	P _{nf} (lb)	P _{ns} (lb)	P _{nf} (lb)	P _{ns} (lb)	P _{nf} (lb)	P _{ns} (lb)	P _{nf} (lb)	P _{ns} (lb)
				Correlation Factor, c		Correlation Factor, c		Correlation Factor, c		Correlation Factor, c	
B	65 (50) ⁴	X-HSN 24 36/3, 36/4, 36/5, 36/7, 36/9, 36/11 $\frac{1}{8} \leq t_r < \frac{3}{16}$	S-SLC 01 M HWH S-SLC 02 M HWH	1,357	844	1,824	1,260	1,865	1,701	-	-
				1.184		1.201		1.233		-	
		X-HSN 24 36/3, 36/4, 36/5, 36/7, 36/9, 36/11 $\frac{3}{16} \leq t_r \leq \frac{3}{8}$	S-SLC 01 M HWH S-SLC 02 M HWH	1,590	844	2,107	1,260	2,663	1,701	3,035	2,024
				1.149		1.127		1.087		1.044	
		X-ENP-19 36/3, 36/4, 36/5, 36/7, 36/9, 36/11 $t_r \geq \frac{1}{4}$	S-SLC 01 M HWH S-SLC 02 M HWH	1,597	844	2,112	1,260	2,764	1,701	3,079	2,024
				1.315		1.259		1.156		1.046	
	92 (80)	X-HSN 24 36/3, 36/4, 36/5, 36/7, 36/9, 36/11 $\frac{1}{8} \leq t_r < \frac{3}{16}$	S-SLC 01 M HWH S-SLC 02 M HWH	1,357	844	1,824	1,260	1,865	1,701	-	-
				1.155		1.172		1.203		-	
		X-HSN 24 36/3, 36/4, 36/5, 36/7, 36/9, 36/11 $\frac{3}{16} \leq t_r \leq \frac{3}{8}$	S-SLC 01 M HWH S-SLC 02 M HWH	1,941	954	2,208	1,341	2,698	1,859	3,095	2,343
				1.052		1.054		1.058		1.062	
		X-ENP-19 36/3, 36/4, 36/5, 36/7, 36/9, 36/11 $t_r \geq \frac{1}{4}$	S-SLC 01 M HWH S-SLC 02 M HWH	1,964	954	2,165	1,341	3,022	1,859	3,577	2,343
				1.197		1.166		1.108		1.046	
BI	65 (50) ⁴	X-HSN 24 36/3, 36/4, 36/5, 36/7, 36/9, 36/11 $\frac{1}{8} \leq t_r < \frac{3}{16}$	S-SLC 01 M HWH S-SLC 02 M HWH	1,357	844	1,712	1,111	1,865	1,591	-	-
				1.184		1.201		1.233		-	
		X-HSN 24 36/3, 36/4, 36/5, 36/7, 36/9, 36/11 $\frac{3}{16} \leq t_r \leq \frac{3}{8}$	S-SLC 01 M HWH S-SLC 02 M HWH	1,516	882	1,712	1,111	2,450	1,591	2,553	2,051
				1.316		1.264		1.168		1.066	

(continued)

TABLE 5—DIAPHRAGM STRENGTH EQUATION VARIABLE VALUES (Continued)

Configuration				Steel Deck Panel Gage Thickness ⁴							
				No. 22		No. 20		No. 18		No. 16 ³	
Deck Type	Minimum Deck Tensile, F _u , (Yield, F _y) Strengths, ksi	Frame Fastener/ Steel Support Framing Thickness, in.	Sidelap Connector ^{1,2}	P _{nf} (lb)	P _{ns} (lb)	P _{nf} (lb)	P _{ns} (lb)	P _{nf} (lb)	P _{ns} (lb)	P _{nf} (lb)	P _{ns} (lb)
				Correlation Factor, c		Correlation Factor, c		Correlation Factor, c		Correlation Factor, c	
Verco PLB	65 (50)	X-HSN 24 36/7, 36/9, 36/11 $\frac{1}{8} \leq t_f < \frac{3}{16}$	Verco VSC2	1,357	2,067	1,712	2,823	1,865	4,323	1,865	4,323
				1.000		1.000		1.000		1.000	
		X-HSN 24 36/7, 36/9, 36/11 $\frac{3}{16} \leq t_f \leq \frac{3}{8}$	Verco VSC2	1,489	2,067	1,795	2,823	2,348	4,323	2,924	5,835
				1.000		1.000		1.000		1.000	
		X-ENP-19 36/6 $t_f \geq \frac{1}{4}$	Verco VSC2	1,624	2,067	1,938	2,823	2,549	4,323	3,149	5,835
				1.056		1.095		1.173		1.251	
		X-ENP-19 36/8 $t_f \geq \frac{1}{4}$	Verco VSC2	1,624	2,067	1,938	2,823	2,549	4,323	3,149	5,835
				1.014		1.004		0.985		0.965	

For SI: 1 inch = 25.4 mm, 1 lbf = 4.45 N, 1 ksi = 6.89 MPa.

¹Sidelap connector spacing must comply with requirements in Table 7.

²For steel deck panel thicknesses applicable to the specific panel sidelap connector, see Table 2.

³See Table 3 for steel deck panel thicknesses in inches [(mils), (mm)].

⁴For steel deck with minimum deck strengths of 55 (40) Tensile, F_u, (Yield, F_y) ksi; the corresponding correlation factors (c) must be calculated by applying a reduction factor of 0.989 for X-HSN 24, and a reduction factor of 0.981 for X-ENP-19. For steel deck with minimum deck strength of 45 (33) Tensile, F_u, (Yield, F_y) ksi; the corresponding correlation factors (c) must be calculated by applying a reduction factor of 0.976 for X-HSN 24, and a reduction factor of 0.956 for X-ENP-19

TABLE 6—DIAPHRAGM STIFFNESS (G') EQUATION VARIABLE VALUES³

Configuration				Steel Deck Panel Gage Thickness ²			
				No. 22	No. 20	No. 18	No. 16
Deck Type	Minimum Deck Tensile, F _u , (Yield, F _y) Strengths, ksi	Frame Fastener	Sidelap Connector ¹	S _f , in./kip	S _f , in./kip	S _f , in./kip	S _f , in./kip
				S _s , in./kip	S _s , in./kip	S _s , in./kip	S _s , in./kip
B or BI	45 to 92 (33 to 80)	X-HSN 24	S-SLC 01 M HWH	0.0073	0.0066	0.0057	0.0051
			S-SLC 02 M HWH	0.0175	0.0159	0.0138	0.0123
		X-ENP-19	S-SLC 01 M HWH	0.0044	0.0040	0.0034	0.0031
			S-SLC 02 M HWH	0.0175	0.0159	0.0138	0.0123
Verco PLB	65 (50)	X-HSN 24	Verco VSC2	0.0073	0.0066	0.0057	0.0051
				0.0360	0.0253	0.0115	0.0074
		X-ENP-19	Verco VSC2	0.0044	0.0040	0.0034	0.0031
				0.0360	0.0253	0.0115	0.0074

For SI: 1 inch = 25.4 mm, 1 in/kip = 5.7 mm/kN, 1 ksi = 6.89 MPa.

¹For steel deck panel thicknesses applicable to the specific panel sidelap connector, see Table 2.

²See Table 3 for steel deck panel thicknesses in inches [(mils),(mm)].

³To be used with equations from AISI S310, Section D5.1.

TABLE 7—MINIMUM SIDELAP CONNECTOR SPACING (SS) FOR HILTI S-SLC 01 M HWH, S-SLC 02 M HWH, AND VERCO VSC2 CONNECTORS INSTALLED IN B-DECK, BI-DECK OR VERCO PLB DECK TYPE (INCHES CENTER ON CENTER)¹

Frame Fastener/ Steel Support Framing Thickness, in.	Deck Gage No.	Frame Fastener Pattern ³							
		36/3	36/4	36/5	36/6	36/7	36/8	36/9 ⁴	36/11 ⁴
X-HSN 24 $\frac{1}{8} \leq t_f < \frac{3}{16}$	22	—	12	12	—	6 ²	—	6 ²	6 ²
	20								
	18								
	16								
X-HSN 24 $\frac{3}{16} \leq t_f \leq \frac{3}{8}$	22	12	6	6	—	3 ²	—	3 ²	3 ²
	20								
	18								
	16								
X-ENP-19 $t_f \geq \frac{1}{4}$	22	6	6	6	4	3	4	3	3
	20								
	18								
	16								

For SI: 1 inch = 25.4 mm, 1 ksi = 6.89 MPa.

¹When the specified sidelap connector spacing is less than those tabulated, the tabulated spacing shall be used in the calculation of diaphragm strength and stiffness when using the values for P_{nf} , P_{ns} and c from Table 5. As an alternate, when the specified sidelap connector spacing is less than those tabulated, but not less than 3 inches, the following values for P_{nf} , P_{ns} and c may replace the values from Table 5:

X-HSN 24 – All deck types, strengths, and steel support framing thicknesses listed in Table 5

- No. 22 Gage (0.0295 in.) – P_{nf} = 1,489 lb, P_{ns} = 716 lb, c = 1.000
- No. 20 Gage (0.0358 in.) – P_{nf} = 1,795 lb, P_{ns} = 869 lb, c = 1.000
- No. 18 Gage (0.0474 in.) – P_{nf} = 2,348 lb, P_{ns} = 1,151 lb, c = 1.000

X-ENP-19 L15 – All deck types, strengths and steel support framing thicknesses listed in Table 5

- No. 22 Gage (0.0295 in.) – P_{nf} = 1,603 lb, P_{ns} = 716 lb, c = 1.000
- No. 20 Gage (0.0358 in.) – P_{nf} = 1,933 lb, P_{ns} = 869 lb, c = 1.000
- No. 18 Gage (0.0474 in.) – P_{nf} = 2,529 lb, P_{ns} = 1,151 lb, c = 1.000

²Noted minimum recommended sidelap connection spacings given for Hilti S-SLC 01 M HWH and S-SLC 02 M HWH sidelap connectors. For Verco VSC2 Connections, the minimum recommended sidelap connection spacing for these configurations is 4 inches.

³Frame fastener patterns recognized for specific deck type, frame fastener, sidelap combinations are shown in Table 5.

⁴For 36/9 and 36/11 patterns, when allowable seismic (or wind) diaphragm shear capacities exceed the values as shown below, the fastening pattern must be increased at the building perimeter, chords, collectors or other shear transfer elements to two fasteners per rib (i.e. 36/14 pattern). The allowable seismic (or wind) diaphragm shear capacity must not be greater than that determined from the 36/9 and 36/11 patterns, as applicable.

X-HSN 24 – with steel support framing thicknesses < $\frac{3}{16}$ -inch

- No. 22 Gage (0.0295 in.) – 1,200 plf (1,275 plf)
- No. 20 Gage (0.0358 in.) – 1,500 plf (1,600 plf)
- No. 18 Gage (0.0474 in.) – 1,700 plf (1,825 plf)

X-HSN 24 – with steel support framing thicknesses $\geq \frac{3}{16}$ -inch

- No. 22 Gage (0.0295 in.) – 1,300 plf (1,400 plf)
- No. 20 Gage (0.0358 in.) – 1,600 plf (1,700 plf)
- No. 18 Gage (0.0474 in.) – 2,100 plf (2,250 plf)
- No. 16 Gage (0.0598 in.) – 2,600 plf (2,775 plf)

TABLE 8—SAFETY FACTORS FOR ALLOWABLE STRENGTH DESIGN (ASD) AND RESISTANCE FACTORS FOR LOAD AND RESISTANCE FACTOR DESIGN (LRFD) IN ACCORDANCE WITH AISI S310¹

LOAD TYPE OR COMBINATIONS INCLUDING	CONNECTION TYPE		CONNECTION RELATED LIMIT STATE	
	FRAME	SIDELAP	Ω_{df} (ASD)	ϕ_{df} (LRFD)
Wind	X-HSN 24, or X-ENP-19 L15	S-SLC 01 M HWH	2.00	0.800
Earthquake and all others		S-SLC 02 M HWH	2.30	0.700
Wind	X-ENP-19 L15, or X-HSN 24	Verco Decking VSC2	2.00	0.800
Earthquake and all others			2.30	0.700

¹The available shear strength or factored shear resistance must be the lesser of the values determined using Table 8 and the tabulated values in Table 9.

TABLE 9—DIAPHRAGM SHEAR STRENGTHS (plf) FOR BUCKLING^{1,2}

Deck Type	Deck Gauge No.	Minimum Moment of Inertia ³ , I_{xg} (in ⁴ /ft)	Span, ℓ_v (ft - in.)									
			Any Span	4'-0"	5'-0"	6'-0"	7'-0"	8'-0"	9'-0"	10'-0"	11'-0"	12'-0"
ASD			S_{nl}/Ω_{nl} ⁴			S_{no}/Ω_{no} where $\Omega_{no} = 2.00$						
B, BI, and Verco PLB	22	0.173	1,661	4,360	2,790	1,938	1,424	1,090	861	698	576	484
	20	0.210	2,350	5,829	3,731	2,591	1,903	1,457	1,151	933	771	648
	18	0.279	3,880	8,904	5,698	3,957	2,907	2,226	1,759	1,425	1,177	989
	16	0.353	5,872	12,644	8,092	5,620	4,129	3,161	2,498	2,023	1,672	1,405
LRFD			$\phi_{nl} S_{nl}$ ⁵			$\phi_{no} S_{no}$ where $\phi_{no} = 0.80$						
B, BI, and Verco PLB	22	0.173	2,658	6,975	4,464	3,100	2,278	1,744	1,378	1,116	922	775
	20	0.210	3,760	9,327	5,969	4,145	3,046	2,332	1,842	1,492	1,233	1,036
	18	0.279	6,208	14,246	9,118	6,332	4,652	3,562	2,814	2,279	1,884	1,583
	16	0.353	9,395	20,231	12,948	8,992	6,606	5,058	3,996	3,237	2,675	2,248

For SI: 1 inch = 25.4 mm, 1 ksi = 6.89 MPa, 1plf = 14.6 N/m, 1 in⁴/ft = 1368 mm⁴/mm.

¹Tabulated values are based on AISI S310 Eq. D2-1 and Eq. D2-2.

²The available shear strength or factored shear resistance must be the lesser of the values determined using Table 8 and the tabulated values in Table 9.

³ I_{xg} is the moment of inertia of the fully effective panel.

⁴For ASD evaluation draft under the 2021 IBC only: Compare allowable S_{nl} / Ω_{nl} (local web buckling) with S_{no} / Ω_{no} for any given span length and use the lower of the two. Provided design values are based on design yield stress, F_y , of 50 ksi and deck end bearing length, N_{ext} , of 3 inches. For other conditions, values must be revised.

⁵For LRFD evaluation under the 2021 IBC only: Compare factored resistance $\Phi_{nl} \times S_{nl}$ (local web buckling) with $\Phi_{no} \times S_{no}$ for any given span length and use the lower of the two. Provided design values are based on design yield stress, F_y , of 50 ksi and deck end bearing length, N_{ext} , of 3 inches. For other conditions, values must be revised.

TABLE 10—ALLOWABLE (ASD) TENSION PULLOUT LOADS TO RESIST TENSION (UPLIFT) LOADS FOR STEEL ROOF DECK PANELS ATTACHED WITH X-HSN 24 OR X-ENP-19 L15 FASTENERS (pounds)^{1,2}

Fastener	Steel Support Framing Thickness, in.						
	¹ / ₈	³ / ₁₆	¹ / ₄	⁵ / ₁₆	³ / ₈	¹ / ₂ ³	\geq ⁵ / ₈ ⁴
ASTM A36 ($F_y = 36$ ksi, $F_u = 58$ ksi)							
X-HSN 24	435	635	750	750	750	-	-
X-ENP-19 L15	-	-	905	1,010	1,125	1,010	965
ASTM A572 Grade 50 or A992 ($F_y = 50$ ksi, $F_u = 65$ ksi)							
X-HSN 24	445	635	750	750	750	-	-
X-ENP-19 L15	-	-	975	1,090	1,205	1,090	1,040

For SI: 1 inch = 25.4 mm, 1 lbf = 4.45 N, 1 ksi = 6.89 MPa.

¹Tabulated allowable (ASD) values based upon a Ω safety factor of 5.0. To obtain LRFD pullout capacities, the tabulated values must be multiplied by 1.6.

²Unless otherwise noted, the tabulated pullout load values are based on minimum penetration of the fasteners of ⁹/₁₆-inch for the X-ENP-19 fasteners. X-HSN 24 tabulated values are based upon fastener stand-off dimensions meeting those shown in Figure 2.

³Tabulated pullout capacities in ¹/₂ -inch steel based upon a minimum point penetration of ¹/₂-inch. If ¹/₂-inch point penetration is not achieved, but a point penetration of at least ³/₈-inch is obtained, the tabulated value must be multiplied by a factor of 0.63.

⁴Tabulated pullout capacities in greater than ⁵/₈-inch steel based upon a minimum point penetration of ¹/₂-inch. If ¹/₂-inch point penetration is not achieved, but a point penetration of at least ³/₈-inch is obtained, the tabulated value must be multiplied by a factor of 0.82.

TABLE 11—ALLOWABLE (ASD) TENSION PULLOVER LOADS TO RESIST TENSION (UPLIFT) LOADS FOR STEEL ROOF DECK PANELS ATTACHED WITH X-HSN 24 OR X-ENP-19 L15 FASTENERS (pounds)^{1, 2}

Fastener	Deck Gage [base-metal thickness, t (inches)]			
	No. 22 (0.0295)	No. 20 (0.0358)	No. 18 (0.0474)	No. 16 (0.0598)
X-HSN 24	500	560	725	865
X-ENP-19 L15	660	705	805	880

For SI: 1 inch = 25.4 mm, 1 lbf = 4.45 N.

¹Tabulated allowable (ASD) values are based upon a Ω safety factor of 3.0. To obtain LRFD pullover capacities, the tabulated values must be multiplied by 1.6.

²Based upon minimum ASTM A653 SS Grade 33 ($F_y = 33$ ksi, $F_u = 45$ ksi) steel deck.

TABLE 12—POST CALCULATION CONVERSION TABLE TO CONVERT SPECIFIED SIDELAP CONNECTOR SPACING (SS) TO NUMBER OF SIDELAP CONNECTORS TO BE INSTALLED PER PANEL SPAN (SPS)^{1, 2}

SIDELAP CONNECTOR SPACING (SS) (inches)	PANEL SPAN									
	3'-0"	4'-0"	5'-0"	6'-0"	7'-0"	8'-0"	9'-0"	10'-0"	11'-0"	12'-0"
3	12	16	20	24	28	32	36	40	44	48
4	9	12	15	18	21	24	27	30	33	36
5	8	10	12	15	17	20	22	24	27	29
6	6	8	10	12	14	16	18	20	22	24
8	5	6	8	9	11	12	14	15	17	18
10	4	5	6	8	9	10	11	12	14	15
12	3	4	5	6	7	8	9	10	11	12
18	2	3	4	4	5	6	6	7	8	8
24	2	2	3	3	4	4	5	5	6	6
30	2	2	2	3	3	4	4	4	5	5
36	1	2	2	2	3	3	3	4	4	4

For SI: 1 inch = 25.4 mm, 1 foot = 304.8 mm.

¹This post calculation conversion table provides the quantity of sidelap connectors per panel span, where the sidelap connectors are specified by spacing. **The numbers of sidelap connectors from this table are not for use in the diaphragm design equations.**

²Conversion of sidelap spacing (SS) to quantity of fasteners at panel sidelaps per span (SPS) is completed using the following formula:

$SPS = ((\text{span in feet}) \times 12) / (\text{SS in inches})$. For SI: $SPS = ((\text{span in meters}) \times 1000) / (\text{SS in millimeters})$. This value is conservatively rounded up to the next whole sidelap connector. A similar approach may be used for intermediate sidelap spacings or joist/beam spans.

FOOTNOTES TO TABLES 4 THROUGH 12

1. Hilti X-HSN 24 or X-ENP-19 L15 frame fasteners must be used at all panel ends, interior supports and panel edges parallel to the panel corrugations. The sides of adjacent panels parallel to the corrugations must be lapped by nesting or interlocking and then fastened with Hilti S-SLC 01 M HWH, Hilti S-SLC 02 M HWH sidelap connectors, or Verco VSC2 sidelap connections along the panel-to-panel side seam overlap.
2. The following apply to diaphragms designed in accordance with this report:
 - a. The deck sheet length is equal to the span times the number of spans.
 - b. For steel deck diaphragms, the number of diaphragm edge fasteners at walls or transfer zones parallel to the deck corrugations must be greater than or equal to the number of stitch sidelap connectors at nearest interior sidelaps.
3. All equations and tables apply to wide rib 1½-inch-deep (38 mm) steel deck panels complying with Section 3.3 of this report.
4. The embedment of Hilti fasteners into the structural support member must be such that the standoff dimension, h_{NVS} in Figures 1 and 2 is obtained.
5. Hilti powder-driven frame fasteners must be centered not less than 1 inch (25 mm) from the panel ends for single fastener in flute and not less than ½-inch (12.7 mm) for two fasteners in flute and not less than 5/16-inch (7.9 mm) from the panel edges parallel to corrugations at the sidelaps.
6. Diaphragm deflections must be considered in the design. Table 13 describes diaphragm limitations.

a. Flexibility Factor F is defined as the average micro-inches a diaphragm web will deflect in a span of one foot under a shear load of one pound per foot. $F = 1000/G'$, micro-inches/pound ($\mu\text{m}/\text{N}$).

b. The general deflection equation is:

$$\frac{d^2y}{dx^2} = M / EI + q / B G'$$

For a uniformly loaded rectangular diaphragm on a simple span, the maximum deflection at the centerline of the diaphragm is:

$$\Delta = 5(1728)qL^4 / 384 EI + qLF / 10^6$$

For **SI**: $\Delta = 5 (1000)^4 qL^4 / 384 EI + qLF / 10^6$

Δ = Diaphragm deflection, inches (mm).

q = Wind or seismic load, kips per lineal foot (N/m)

q_{ave} = Average shear in diaphragm in pounds per foot (N/m) over length L .

L = Length of diaphragm normal to load, feet (m).

B = Width of diaphragm parallel to load, feet (m).

E = Modulus of elasticity of supporting steel chord or flange material.

I = Moment of inertia, inches⁴ (mm⁴).

Diaphragm deflection equations provided apply to rectangular symmetrical diaphragms only. Nonrectangular diaphragms, nonsymmetrical diaphragms with re-entrant corners or diaphragms subjected to torsional loadings require special design considerations.

- c. Roof diaphragms supporting masonry or concrete walls must have their deflections limited to the following:

$$\Delta = H^2 f_c / 0.01Et$$

For **SI**: $\Delta = 694000 H^2 f_c / Et$

Δ = Deflection of top of wall, inches (mm).

H = Wall height, feet (mm).

T = Thickness of the wall, inches (mm).

E = Modulus of elasticity of the wall material, psi (kPa).

f_c = Allowable flexural compressive strength of the wall material, psi (kPa). For masonry $f_c = 0.33f_m$; for concrete $f_c = 0.45f_c$.

7. All end perimeter and interior members and their attachments must be designed to resist all applied loads.

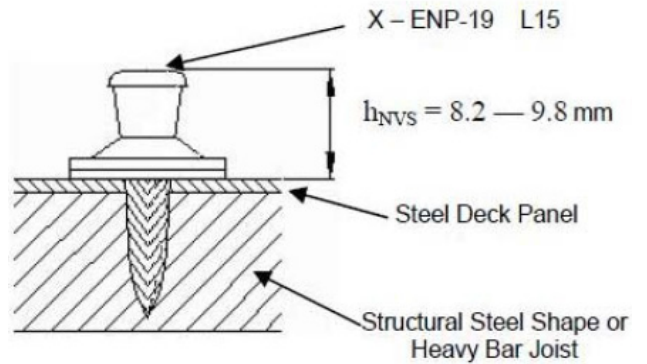

FIGURE 1—NAIL HEAD STANDOFF (h_{NVS}) FOR X-ENP-19 L15 FASTENER

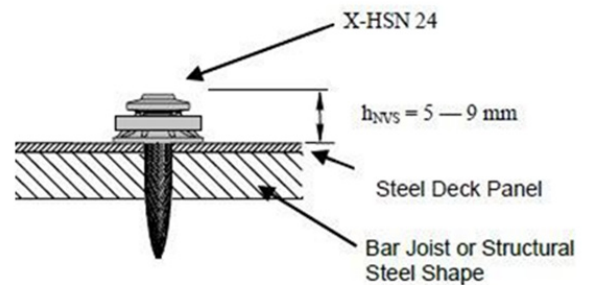

FIGURE 2—NAIL HEAD STANDOFF (h_{NVS}) FOR X-HSN 24 FASTENER

TABLE 13—DIAPHRAGM FLEXIBILITY LIMITATION^{1,2,3,4,5}

(Only applicable to the 2015 IBC and earlier codes)

F	MAXIMUM SPAN IN FEET FOR MASONRY OR CONCRETE WALLS	SPAN-DEPTH LIMITATION			
		Rotation Not Considered in Diaphragm		Rotation Considered in Diaphragm	
		Masonry or Concrete Walls	Flexible Walls	Masonry or Concrete Walls	Flexible Walls
More than 150	Not used	Not used	2:1	Not used	1½:1
70 – 150	200	2:1 or as required for deflection	3:1	Not used	2:1
10 – 70	400	2½:1 or as required for deflection	4:1	As required for deflection	2½:1
1 – 10	No limitation	3:1 or as required for deflection	5:1	As required for deflection	3:1
Less than 1	No limitation	As required for deflection	No limitation	As required for deflection	3½:1

For SI: 1 inch = 25.4 mm, 1 foot = 304.8 mm, 1 plf = 14.594 N/m, 1 psi = 6894 Pa.

¹Diaphragms are to be investigated regarding their flexibility and recommended span-depth limitations.

²Diaphragms supporting masonry or concrete walls are to have their deflections limited to the following amount:

$$\Delta_{wall} = \frac{H^2 f_c}{0.01 Et} \quad \text{For SI: } \Delta_{wall} = \frac{694,000 H^2 f_c}{Et}$$

where:

- H = Unsupported height of wall in feet or millimeters.
- t = Thickness of wall in inches or millimeters.
- E = Modulus of elasticity of wall material for deflection determination in pounds per square inch or kilopascals.
- f_c = Allowable compression strength of wall material in flexure in pounds per square inch or kilopascals. For concrete, f_c = 0.45 f_c. For masonry, f_c = F_b = 0.33 f_m.

³The total deflection Δ of the diaphragm may be computed from the equation: Δ = Δ_r + Δ_w.

where:

- Δ_r = Flexural deflection of the diaphragm determined in the same manner as the deflection of beams.
- Δ_w = The web deflection may be determined by the equation:

$$\Delta_w = \frac{q_{ave} L F}{10^6} \quad \text{For SI: } \Delta_w = \frac{q_{ave} L F}{175}$$

where:

- L = Distance in feet between vertical resisting element (such as shear wall) and the point to which the deflection is to be determined.
- q_{ave} = Average shear in diaphragm in pounds per foot or newtons per meter over length L.
- F = Flexibility factor: The average microinches or micrometers (μm) a diaphragm web will deflect in a span of 1 foot (m) under a shear of 1 pound per foot (N/m).

⁴When applying these limitations to cantilevered diaphragms, the allowable span-depth ratio will be half that shown.

⁵Diaphragm classification (flexible or rigid) and deflection limits shall comply with Section 4.1.

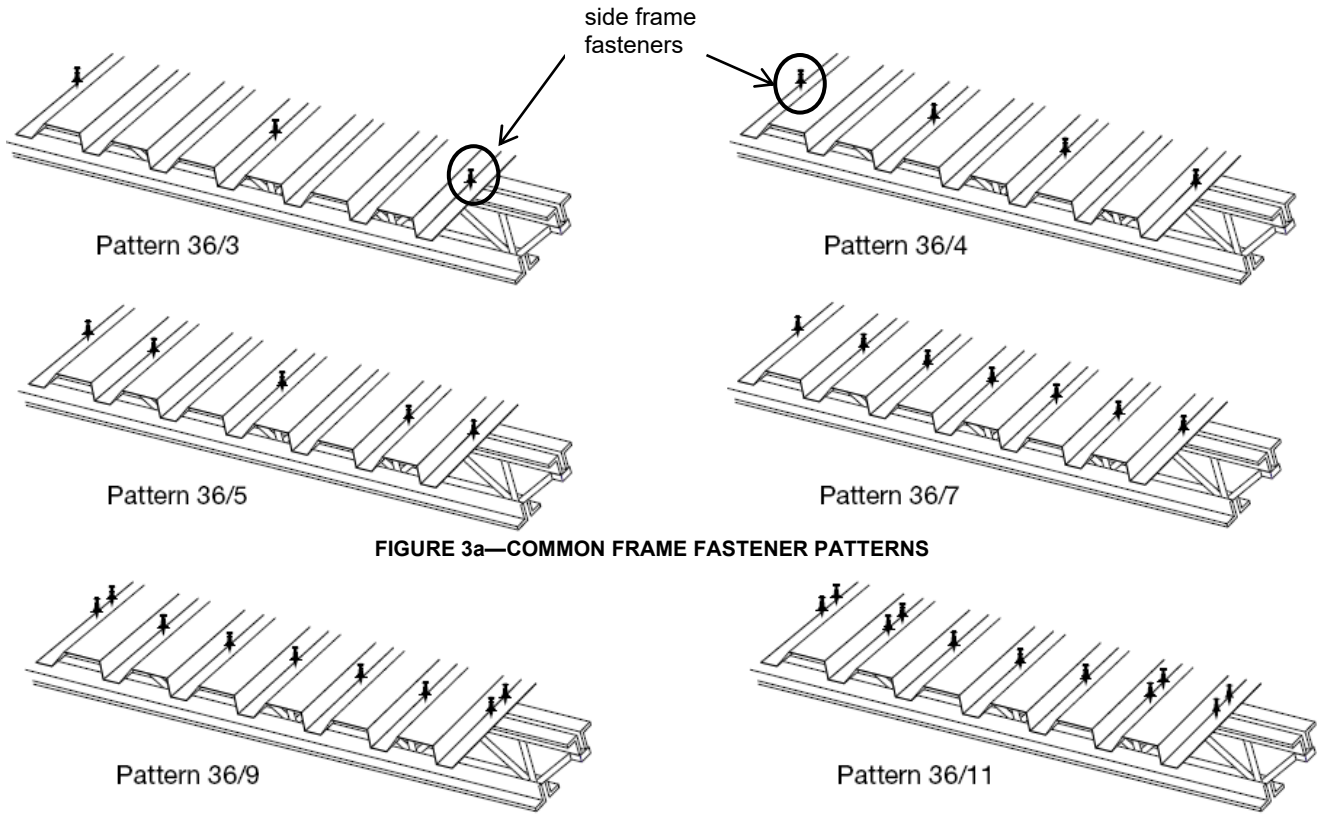

FIGURE 3a—COMMON FRAME FASTENER PATTERNS

Notes:

1. B-Deck shown for illustration purposes only. See Table 3 for applicable decks.
2. Bar joist shown. Connection to structural steel members is also allowed by this report as set forth in Table 1 and Figure 7.
3. For B-Decks, the side frame fasteners are installed through both connecting steel decks and into the supporting framing.
4. For BI-Decks and Verco PLB Decks, the same number of side frame fasteners, are installed on each side of the sidelap and into supporting framing.

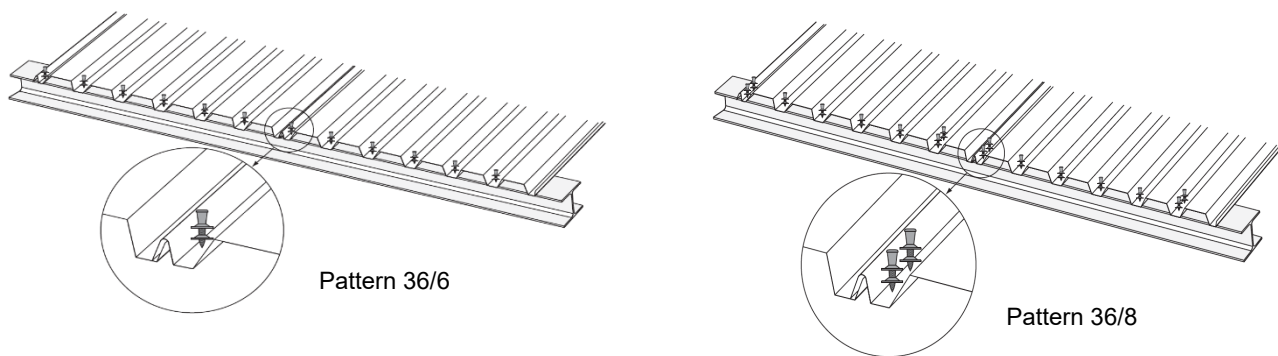
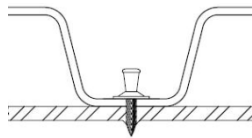
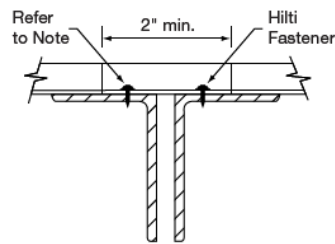

FIGURE 3b—HILTI X-ENP-19 FRAME FASTENER PATTERNS WITH VERCO PLB DECK



4a. Powder-Driven Fastener Attachment of Steel Deck to Frame



Note: Some fastener patterns may require two fasteners. Fasteners may be installed on either side of the structural steel beam or bar joist.

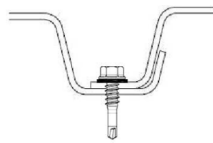

4c. Sidelap Connector with B-Deck

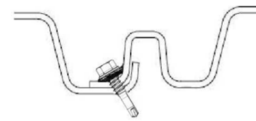

4d. Sidelap Connector with BI-Deck

- ① PunchLok®II system connection - "2M/3F" condition as shown, the side of the tool with two blades starts off placed on the male side of the sidelap.
- ② Sheared surface of male leg.
- ③ Sheared surface of female leg.
- ④ Male leg / sheet.
- ⑤ Female leg / sheet.

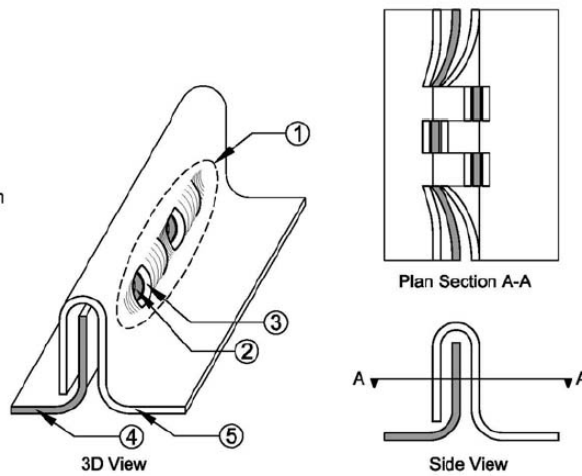

4e. Verc VSC 2 Connection

FIGURE 4—TYPICAL FRAME, ENDLAP AND SIDELAP CONNECTIONS



SDK2 Sealing Cap

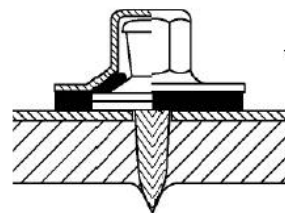

Note: To be used with X-ENP-19 L15 fasteners. X-ENP-19 Nailhead standoff (h_{NVS}) must be as shown in Figure 1

FIGURE 5—SDK2 SEALING CAP

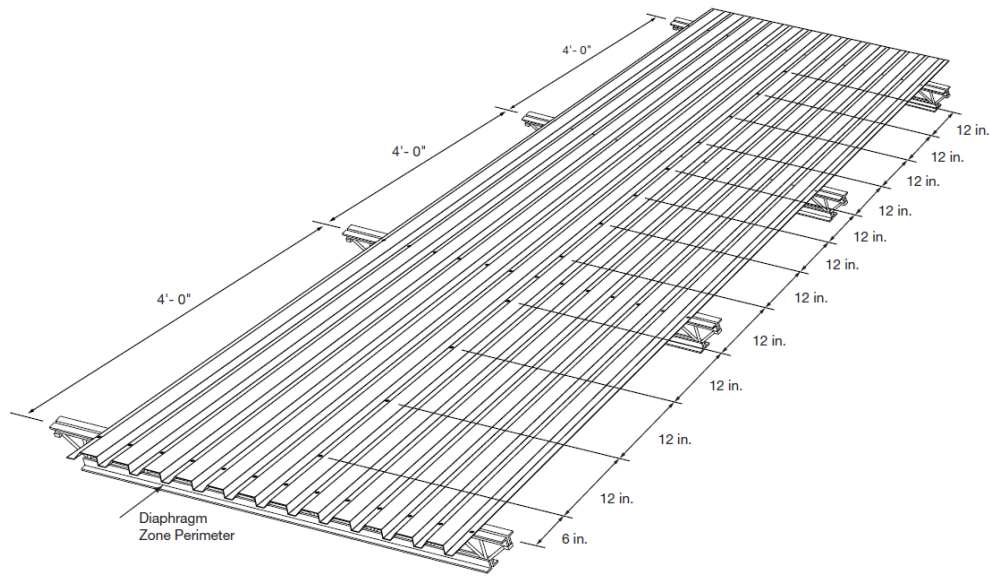

Example: A 4'-0" span with a 12 in. sidelap connector spacing will typically start 6 in. from the first joist / beam line at the diaphragm zone perimeter, and then have equal spacings of 12 in. across the entire diaphragm length or width, off-set at the interior joist / beam locations. The interior joist / beam fastening locations are frame fasteners and not sidelap connectors. This convention of specifying sidelap connectors by spacing does not consider each deck span independently as a discrete element, but rather as a larger steel deck diaphragm system consisting of 3 or more spans.

Note: If the sidelap connector spacing does not divide evenly into the span length, some spans may have more sidelap connectors than adjacent spans. For this reason, n_e and n_s may not be whole numbers.

6a: SPECIFIED BY SIDELAP CONNECTOR SPACING (SS)

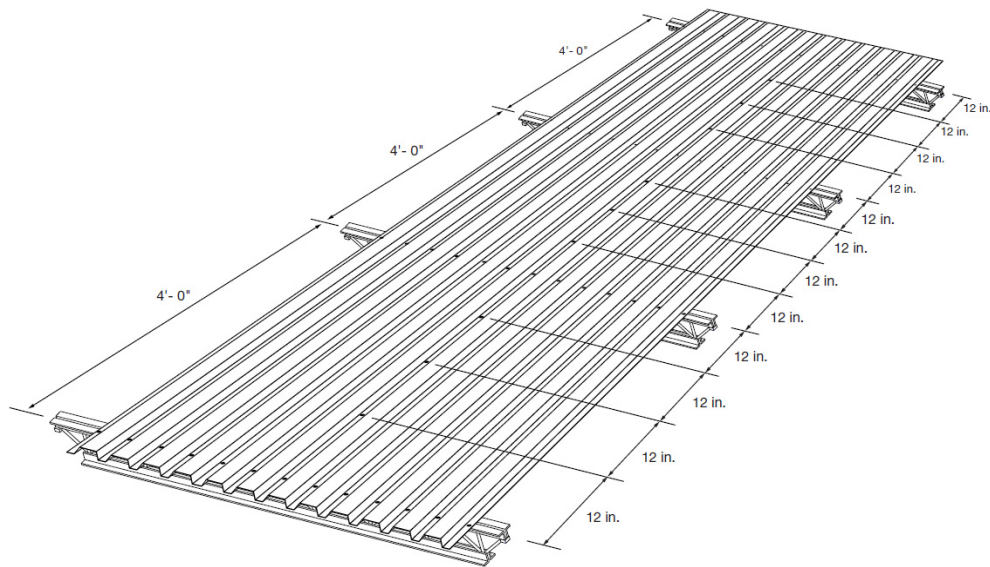

Example: A 4'-0" span specified with 3 sidelap connectors per span will have 3 sidelap connectors evenly spaced 12 in. from each joist/ beam line and each other making 4 equal 12 in. spaces per span. This convention of specifying sidelap connectors by the number of sidelap connectors per span considers each deck span independently as a discrete element.

6b: SPECIFIED BY NUMBER OF SIDELAP CONNECTORS PER SPAN (SPS)

FIGURE 6—EXAMPLE ILLUSTRATION OF SIDELAP CONNECTOR SPECIFICATION CONVENTIONS - SPACING OR NUMBER PER SPAN (REF. TABLE 12 FOR CONVERSION OF SIDELAP CONNECTOR SPACINGS FOR JOIST / BEAM SPAN COMBINATIONS)

Bar Joist (Open Web Joists) Applications

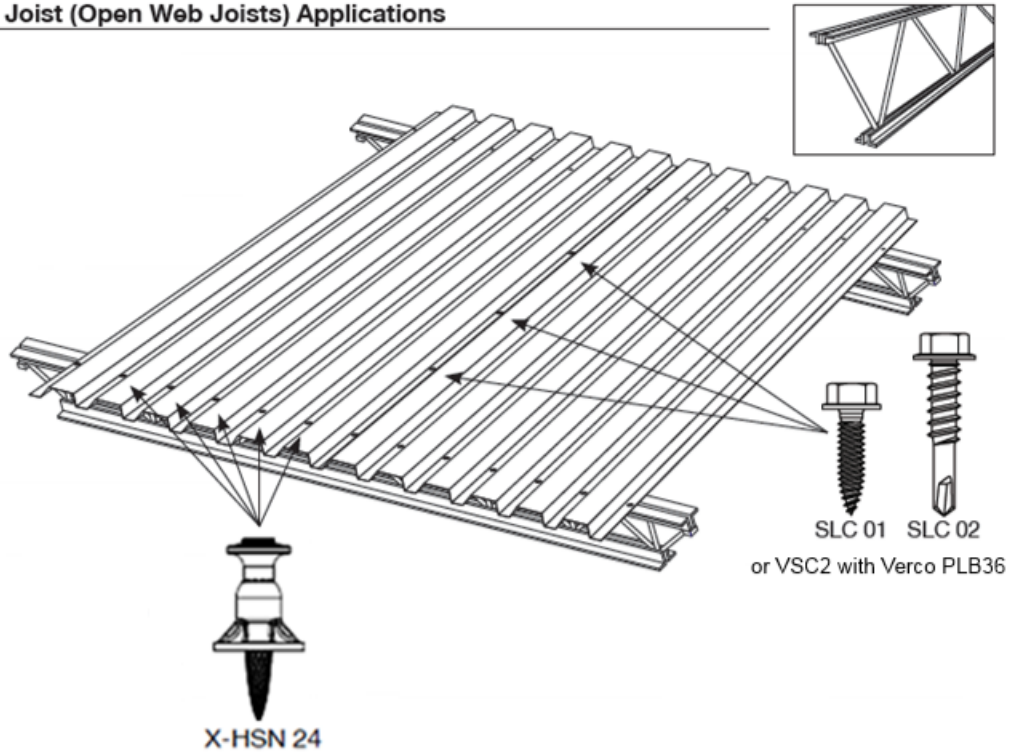

Structural Steel Applications

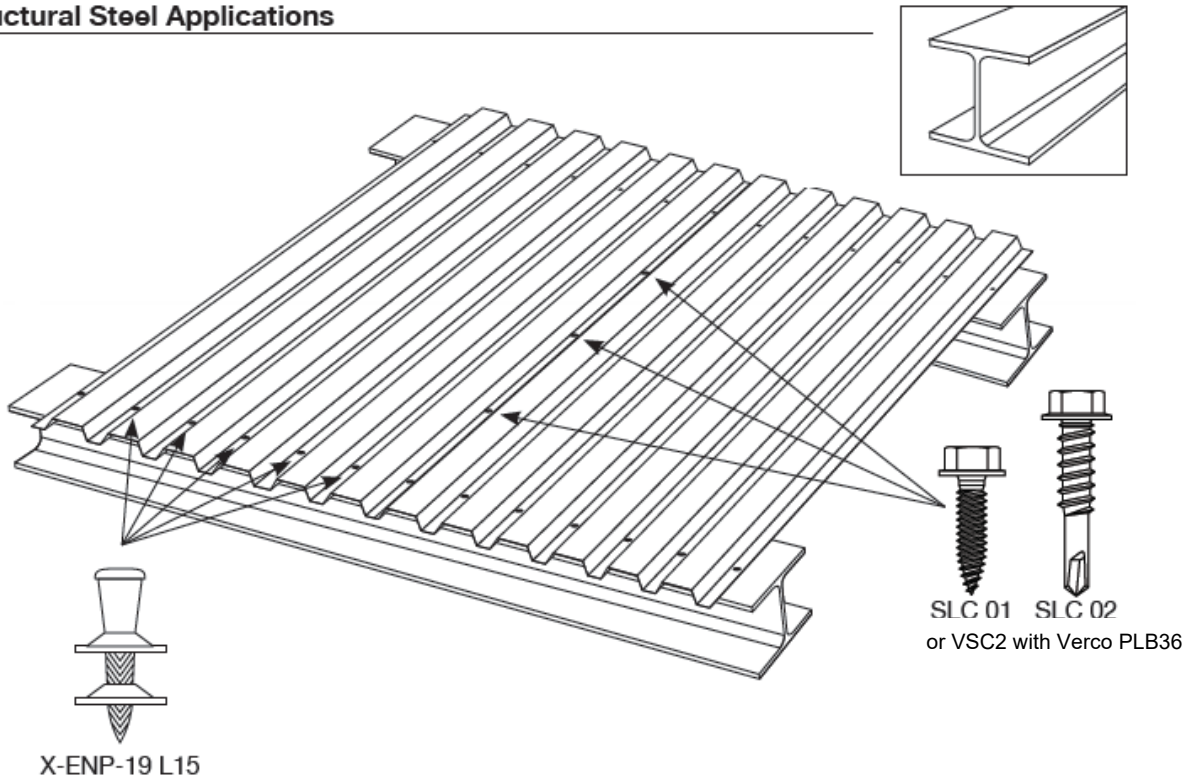
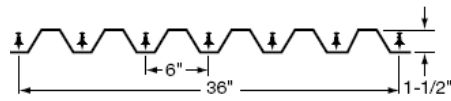

FIGURE 7—HILTI DECK FASTENER INSTALLATION OVERVIEW

Given:

Load Type: Seismic Design
 Support Span, L_v : 6'-0"
 No. of Spans: 3
 Total Length, L : 18'-0"
 Deck: No. 20 gage (0.0358 inch) 1 1/2" deep B-Deck ($F_y = 50$ ksi)
 Support Framing: Steel Bar Joist with 1/4" Thick Top Chord
 Frame Fastener: X-HSN 24
 Frame Fastener Pattern: 36/7
 Sidelap Fastener: S-SLC 02 M HWH
 Sidelap Fastener Spacing (SS): 12" o.c.



Problem:

Determine Allowable (ASD) Diaphragm Shear Strength ($\frac{S_{ni}}{\Omega}$) and Stiffness (G') for the given steel deck diaphragm.

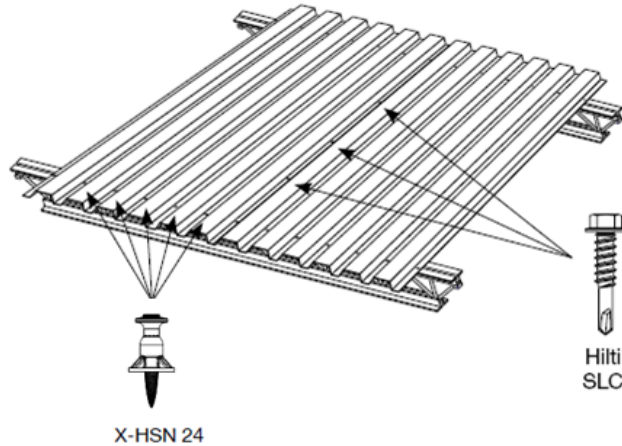

Step 1: Calculate Nominal Diaphragm Shear Strength Limited by Interior Panel Fasteners:

$$S_{ni} = \{2A(\lambda-1)+\beta\} \times \frac{P_{nf}}{L} = \{2 \times 1 \times (0.802-1)+16.99\} \times \frac{2,107}{18} = 1,942 \text{ plf}$$

AISI S310 Eq. D1-1

where:

$$A = 1$$

ESR-2776 Table 4

$$\lambda = 1 - \frac{D_d L_v}{240 \sqrt{t}} = 1 - \frac{1.5 \times 6}{240 \sqrt{0.0358}} = 0.802 \geq 0.7$$

AISI S310 Eq. D1-4a

$$\beta = n_s \alpha_s + 2n_p \alpha_p^2 + 4\alpha_e^2$$

AISI S310 Eq. D1-5

$$\alpha_p^2 = \left(\frac{1}{w^2}\right) \sum x_p^2$$

AISI S310 Eq. D1-7

$$\alpha_e^2 = \left(\frac{1}{w^2}\right) \sum x_e^2$$

AISI S310 Eq. D1-8

$$n_p = 2$$

$$\beta = n_s \alpha_s + 2n_p \alpha_p^2 + 4\alpha_e^2 = \frac{1}{w^2} \times \left[2 \times 2.0 \times \sum (x_p^2) + 4 \sum (x_e^2)\right] = 18 \times 0.598 + \frac{[2 \times 2 \times 1,008 + 4 \times 1,008]}{36^2} = 16.99$$

$$\sum (x_p^2) = \sum (x_e^2) = 1,008$$

ESR-2776 Table 4

$$\alpha_s = \frac{P_{ns}}{P_{nf}} = \frac{1,260}{2,107} = 0.598$$

AISI S310 Eq. D1-5

Step 2: Calculate Nominal Diaphragm Shear Strength Limited by Corner Fasteners:

$$S_{nc} = P_{nf} \times \sqrt{\frac{N^2 \times \beta^2}{L^2 \times N^2 + \beta^2}} = 2,107 \times \sqrt{\frac{2.00^2 \times 16.99^2}{18^2 \times 2.00^2 + 16.99^2}} = 1,798 \text{ plf}$$

AISI S310 Eq. D1-2

where:

$$N = 2.00$$

ESR-2776 Table 4

β = same as in Step 1

FIGURE 8—DIAPHRAGM DESIGN EXAMPLE

Step 3: Calculate Nominal Diaphragm Shear Strength Limited by Edge Fasteners:

$$S_{ne} = \frac{\{2 \alpha_1 + n_p \alpha_2\} P_{nf} + n_e P_{nfs}}{L} = \frac{\{2 \times 2 + 2 \times 2\} \times 2,107 + 18 \times 2,107}{18} = 3,043 \text{ plf} \quad \text{AISI S310 Eq. D1-3}$$

where:

$$\alpha_1 = \alpha_2 = 2 \quad \text{ESR-2776 Table 4}$$

$$P_{nf} = P_{nfs}$$

$$n_e = \frac{L \times 12}{SS} = \frac{18 \times 12}{12} = 18$$

Step 4: Calculate Nominal Diaphragm Shear Strength Limited by Edge Fasteners:

$$S_{np} = n_d \times P_{nf} \times \frac{1}{W_t} = 1 \times 2,107 \times \frac{1}{0.5} = 4,214 \text{ plf} \quad (\text{For fluted Panels}) \quad \text{AISI S310 Eq. D1-4a}$$

where:

$$n_d = 1 \quad \text{1 fastener per flute}$$

$$P_{nf} = 2,107 \text{ lbs} \quad \text{ESR-2776, Table 5}$$

$$W_t = 6" = 0.5 \text{ ft} \quad \text{Tributary width for "B" deck}$$

Step 5: Calculate Nominal Diaphragm Shear Strength Controlled By Connections and Adjusted by the Correlation Factor

$$S_{nf} = \min (S_{ni}, S_{nc}, S_{np} \text{ and } S_{ne})c = 1,798 \times 1.127 = 2,026 \text{ plf}$$

where:

$$c = 1.127 \quad \text{ESR-2776 Table 5}$$

Step 6: Calculate Allowable Diaphragm Shear Strength

$$\frac{S_{nf}}{\Omega_{nf}} = \frac{2,026}{2.30} = 881 \text{ plf}$$

where:

$$\Omega_{nf} = 2.30 \quad \text{ESR-2776 Table 8}$$

Step 7: Select Controlling Diaphragm Buckling Strength and Calculate Allowable Diaphragm Buckling Strength

$$S_{nb} = \min \left(\frac{S_{no}}{\Omega_{no}} \text{ \& } \frac{S_{ni}}{\Omega_{ni}} \right) = 2,350 \text{ plf} \quad \text{ESR-2776 Table 9}$$

Step 8: Determine Controlling Allowable Diaphragm Shear Strength

$$\frac{S_n}{\Omega} = \left(\frac{S_{nf}}{\Omega_{nf}}, \frac{S_{nb}}{\Omega_{nb}} \right) = 881 \text{ plf} \quad \text{AISI S310 Eq. D-1}$$

Step 9: Determine Diaphragm Stiffness:

$$G' = \left(\frac{Et}{2(1+\mu)\frac{s}{d} + \gamma_c D_n + C} \right) \text{K, kips/in.} \quad \text{AISI S310 Eq. D5.1.1-1}$$

$$G' = \left(\frac{Et}{2(1+\mu)\frac{s}{d} + \gamma_c D_n + C} \right) \text{K} = \frac{Et}{3.549 + 0.9D + C} = \frac{29,500 \times 0.0358}{3.549 + 0.9D_n + C} = 95.6 \text{ kips/in.}$$

$$F = \frac{1000}{G'} = \frac{1000}{95.6} = 10.46 \text{ micro-inches/lb}$$

where:

$$D_n = \frac{D}{L} = \frac{924}{18 \times 12} = 4.28 \quad \text{AISI S310 Eq. 1.4-1}$$

(Step 8 continued)

FIGURE 8—DIAPHRAGM DESIGN EXAMPLE (Continued)

D = 1,164 in.

ESR-2776 Table 4

$$C = \left(\frac{Et}{w}\right) \left(\frac{2L}{2\alpha_3 + n_p\alpha_4 + 2n_s\frac{S_f}{S_s}}\right) S_f = \left(\frac{29,500 \times 0.0358}{36}\right) \left(\frac{2 \times 18 \times 12}{2 \times 2 + 2 \times 2 + 2 \times 18 \times \frac{0.0066}{0.0159}}\right) 0.0066 = 3.65$$

AISI S310 Eq. D5.1.1-2

where:

$n_s = 18$, same as Step 3

$n_p = 2$

$\alpha_3 = \alpha_4 = 2$

ESR-2776 Table 4

$S_f = 0.0066$

ESR-2776 Table 6

$S_s = 0.0159$

ESR-2776 Table 6

NOTE: Straight-line interpolation between different steel deck thicknesses and steel deck strengths for the calculation of diaphragm shear strength values is permitted. For example, to calculate the allowable diaphragm shear strength, $\frac{S_n}{\Omega}$, for 80 ksi steel deck, the following formula would be used.

$$\frac{S_n}{\Omega} (80 \text{ ksi}) = \frac{S_n}{\Omega} (65 \text{ ksi}) + (80 \text{ ksi} - 65 \text{ ksi}) \times \left| \frac{\frac{S_n}{\Omega} (92 \text{ ksi}) - \frac{S_n}{\Omega} (65 \text{ ksi})}{92 - 65} \right|$$

where:

$\frac{S_n}{\Omega} (65 \text{ ksi})$ = Allowable diaphragm shear for 45 ksi steel deck as calculated per Section 4.1.2 of this report.

$\frac{S_n}{\Omega} (92 \text{ ksi})$ = Allowable diaphragm shear for 92 ksi steel deck as calculated per Section 4.1.2 of this report.

$\frac{S_n}{\Omega} (80 \text{ ksi})$ = Allowable diaphragm shear for 80 ksi steel deck.

Similarly, to calculate the allowable diaphragm shear, S_{ASD} , for 19 gauge (0.0418 in.) steel deck, the following formula would be used.

$$\frac{S_n}{\Omega} (19 \text{ Ga.}) = \frac{S_n}{\Omega} (20 \text{ Ga.}) + (0.0418 \text{ in.} - 0.0358 \text{ in.}) \times \frac{\frac{S_n}{\Omega} (18 \text{ Ga.}) - \frac{S_n}{\Omega} (20 \text{ Ga.})}{0.0474 \text{ in.} - 0.0358 \text{ in.}}$$

where:

$\frac{S_n}{\Omega} (20 \text{ Ga.})$ = Allowable diaphragm shear for 20 gauge (0.0358 in.) steel deck as calculated per Section 4.1.2 of this report.

$\frac{S_n}{\Omega} (18 \text{ Ga.})$ = Allowable diaphragm shear for 18 gauge (0.0474 in.) steel deck as calculated per Section 4.1.2 of this report.

$\frac{S_n}{\Omega} (19 \text{ Ga.})$ = Allowable diaphragm shear for 19 gauge (0.0418 in.) steel deck.

FIGURE 8—DIAPHRAGM DESIGN EXAMPLE (Continued)

DIVISION: 05 00 00—METALS
Section: 05 05 23—Metal Fastenings
Section: 05 31 00—Steel Decking

REPORT HOLDER:

HILTI, INC.

EVALUATION SUBJECT:

STEEL DECK DIAPHRAGMS ATTACHED WITH HILTI X-HSN 24 OR X-ENP-19 L15 POWDER-DRIVEN FRAME FASTENERS AND HILTI S-SLC 01 M HWH OR S-SLC 02 M HWH SIDELAP CONNECTORS, OR VERCO DECKING VSC2 SIDELAP CONNECTION

1.0 REPORT PURPOSE AND SCOPE**Purpose:**

The purpose of this evaluation report supplement is to indicate that Steel Deck Diaphragms attached with Hilti X-HSN 24 or X-ENP-19 L15 Powder-Driven Frame Fasteners and Hilti S-SLC 01 M HWH Or S-SLC 02 M HWH Sidelap Connectors, or Verco Decking VSC2 Sidelap Connection, described in ICC-ES evaluation report [ESR-2776](#), have also been evaluated for compliance with the code noted below as adopted by the Los Angeles Department of Building and Safety (LADBS).

Applicable code edition:2023 *City of Los Angeles Building Code* (LABC)**2.0 CONCLUSIONS**

The Steel Deck Diaphragms attached with Hilti X-HSN 24 Or X-ENP-19 L15 Powder-Driven Frame Fasteners and Hilti S-SLC 01 M HWH or S-SLC 02 M HWH Sidelap Connectors, or Verco Decking VSC2 Sidelap Connection, described in Sections 2.0 through 7.0 of the evaluation report [ESR-2776](#), comply with LABC Chapter 22, and are subjected to the conditions of use described in this supplement.

3.0 CONDITIONS OF USE

The Steel Deck Diaphragms attached with Hilti X-HSN 24 Or X-ENP-19 L15 Powder-Driven Frame Fasteners and Hilti S-SLC 01 M HWH or S-SLC 02 M HWH Sidelap Connectors, or Verco Decking VSC2 Sidelap Connection, described in this evaluation report supplement must comply with all of the following conditions:

- All applicable sections in the evaluation report [ESR-2776](#).
- The design, installation, conditions of use and identification are in accordance with the 2021 *International Building Code*® (IBC) provisions noted in the evaluation report [ESR-2776](#).
- The design, installation and inspection are in accordance with additional requirements of LABC Chapters 16 and 17, as applicable.
- Diaphragm shear strength values in the evaluation report must not be increased for load combinations that include wind or seismic loads.
- For diaphragms that are used to provide wall anchorage, the adequacy of the steel deck panel end and side seam connections must be verified by a design professional to the satisfaction of the code official.

This supplement expires concurrently with the evaluation report, reissued April 2023 and revised November 2023.

DIVISION: 05 00 00—METALS
Section: 05 05 23—Metal Fastenings
Section: 05 31 00—Steel Decking

REPORT HOLDER:

HILTI, INC.

EVALUATION SUBJECT:

STEEL DECK DIAPHRAGMS ATTACHED WITH HILTI X-HSN 24 OR X-ENP-19 L15 POWDER-DRIVEN FRAME FASTENERS AND HILTI S-SLC 01 M HWH OR S-SLC 02 M HWH SIDELAP CONNECTORS, OR VERCO DECKING VSC2 SIDELAP CONNECTION

1.0 REPORT PURPOSE AND SCOPE**Purpose:**

The purpose of this evaluation report supplement is to indicate that Hilti's X-HSN 24 and X-ENP-19 L15 powder-driven frame fasteners and Hilti's S-SLC 01 M HWH and S-SLC 02 M HWH sidelap connectors, described in ICC-ES evaluation report ESR-2776, have also been evaluated for compliance with the code noted below.

Applicable code edition:2023 *Florida Building Code—Building***2.0 CONCLUSIONS**

The Hilti's X-HSN 24 and X-ENP-19 L15 powder-driven fasteners and Hilti's S-SLC 01 M HWH and S-SLC 02 M HWH sidelap connectors, described in Sections 2.0 through 7.0 of ICC-ES evaluation report ESR-2776, comply with the *Florida Building Code—Building*. The design requirements must be determined in accordance with *Florida Building Code—Building*. The installation requirements noted in ICC-ES evaluation report ESR-2776 for the 2021 *International Building Code*® (IBC) meet the requirements of the *Florida Building Code—Building*.

Use of the powder-driven fasteners and sidelap connectors has also been found to be in compliance with the High-Velocity Hurricane Zone provisions of the *Florida Building Code—Building* and must comply with the following Condition of Use:

When the powder-driven fasteners and sidelap connectors are used with 22 gage or less (thinner) steel decking, the steel decking must have minimum G90 galvanizing in accordance with Section 2222.6.1 of the FBC.

For products falling under Florida Rule 61G20-3, verification that the report holder's quality-assurance program is audited by a quality-assurance entity approved by the Florida Building Commission for the type of inspections being conducted is the responsibility of an approved validation entity (or the code official, when the report holder does not possess an approval by the Commission).

This supplement expires concurrently with the evaluation report, reissued April 2023 and revised November 2023.