

METAL PIPE	
TYPE	MAX. DIA.
STEEL PIPE (SCH. 10 OR HEAVIER)	30"
CAST IRON PIPE	30"
COPPER PIPE	6"
STEEL CONDUIT	6"
EMT	4"

1 METAL PIPE THROUGH CONCRETE OVER METAL DECKING (3-HR.)
E.3.4 NOT TO SCALE

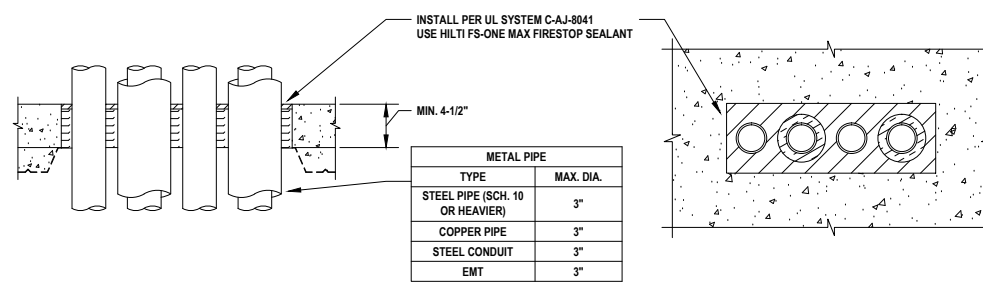

METAL PIPE	
TYPE	MAX. DIA.
STEEL PIPE (SCH. 10 OR HEAVIER)	3"
COPPER PIPE	3"
STEEL CONDUIT	3"
EMT	3"

2 MULTIPLE METAL PIPES THROUGH CONCRETE OVER METAL DECKING (3-HR.)
E.3.4 NOT TO SCALE

- Notes:
- Refer to the following specifications for firestopping.
 - 07 84 00 Firestopping
 - 07 84 13 Penetration Firestopping
 - 22 00 00 Plumbing
 - 23 00 00 HVAC
 - 26 00 00 Electrical
 - 27 06 37 Communication

For Quality Control requirements, refer to the Quality Control portion of the specification.
2. Details shown are typical details, containing general information only. Always refer to the full UL system detail for complete system requirements. If field conditions do not match requirements of details, approved alternate details shall be utilized. Design requirements, field conditions and dimensions need to be verified for compliance with the details, including but not limited to the following:

- * Fire Rating (F-Rating)
- * Temperature Rating (T-Rating)
- * Leakage Rating (L-Rating)
- * Water Rating (W-Rating)
- * Annular Space
- * Percent Fill
- * Movement
- * Type and thickness of fire-rated construction.

3. If alternate details matching the field conditions are not available, manufacturer's engineering judgment drawings are acceptable. Contact Hilti Inc. for alternative systems or Engineering Judgment (800-879-8000) Drawings shall follow the International Firestop Council (IFC) Guidelines for Evaluating Firestop Systems Engineering Judgments.

4. References:
- * 2013 Underwriter's Laboratories Fire Resistance Directory, Volumes 1 & 2
 - * NFPA 101 Life Safety Code
 - * NFPA 70 - National Electric Code
 - * All governing local and regional building codes
5. Firestop System installation must meet requirements of ASTM E-814 (UL 1479) tested assemblies that provide a fire rating equal to that of construction being penetrated.
6. All rated through-penetration assemblies shall be prominently labeled with a Hilti Firestop Label equipped with a QR code with the following information:
- * Warning! - Do Not Disturb
 - * Through Penetration Firestop System
 - * UL System # * Product(s) used
 - * Hourly Rating (F-Rating)
 - * Installation Date
 - * Contractor's Name
7. For outlet boxes requiring protection, use only Wall Opening Protective Materials, category CLIV as classified by Underwriter's Laboratories, Fire Resistance Directory (Volume 1.)

<Notes to designer (delete this note after reading and replace with title block information)>
 1. Any modification to these details could result in an application/system not meeting the UL or Intertek Classification or the intended temperature or fire ratings.
 2. Details shown are up to date as of February 2015.
 3. For additional information on the details, refer to the most current "Underwriter's Laboratories Fire Resistance Directory (volume 2.)"

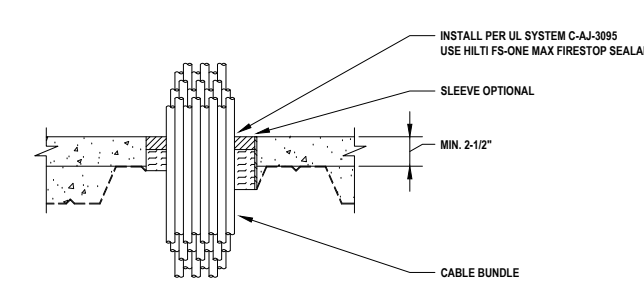

CABLE BUNDLE CONSISTS OF:			
TYPE	MAX.	TYPE	MAX.
TELEPHONE CABLE WITH PVC JACKET	300 PAIR NO. 24 AWG	METAL-CLAD CABLE	3/4" NO. 12 AWG
POWER CABLE WITH PVC JACKET (COPPER CONDUCTOR)	500 KCMIL	COPPER CONDUCTOR SER CABLE WITH PVC JACKET	3/4" (+GROUND) 2/0 AWG
POWER CABLE WITH PVC JACKET (ALUMINUM OR COPPER CONDUCTOR)	350 KCMIL	COAXIAL CABLE WITH FLUORINATED ETHYLENE JACKET	RG/U
POWER CABLE WITH PVC JACKET	7/8" NO. 12 AWG	CABLE WITH PVC JACKET	3/4" NO. 6 AWG
FIBER OPTIC CABLE (24 FIBER)	1/2" DIA.	SINGLE OR MULTIPLE CONDUCTOR TYPE MI CABLE (MIN. 1/8" SEPARATION BETWEEN MI CABLES AND ANY OTHER TYPES OF CABLE)	1-1/4" DIA.

3 CABLE BUNDLE THROUGH CONCRETE OVER METAL DECKING (3-HR.)
E.3.4 NOT TO SCALE

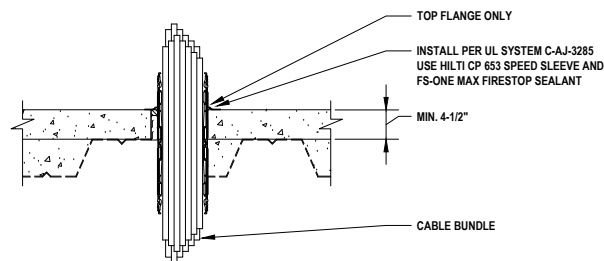

CABLE BUNDLE CONSISTS OF:			
TYPE	MAX.	TYPE	MAX.
TELEPHONE CABLE WITH PVC JACKET	100 PAIR NO. 24 AWG	FIBER OPTIC CABLE (24 FIBER) WITH PVC OR PE JACKET AND INSULATION	1/2" DIA.
COPPER CONDUCTOR CONTROL CABLE WITH PVC OR XLPE JACKET AND INSULATION	7/8" NO. 12 AWG	SHIELDED PRINTER CABLE WITH PVC JACKET	20/8" NO. 22 AWG
TYPE RHH GROUND CABLE	4/0 AWG	POWER OR NON-POWER LIMITED FIRE ALARM CABLE WITH OR WITHOUT METAL JACKET (MAN. BY AFC CABLE SYSTEMS, INC.)	2/8" NO. 18 AWG
COMPUTER CABLE	4 PAIR NO. 22 AWG CAT 6	S-VIDEO CABLE CONSISTING OF TWO MAX. 24 AWG 75 OHM COAX OR TWISTED PAIR CABLE WITH PE INSULATION AND PVC JACKET	1/4" DIA.
COAXIAL CABLE	RG 6/U		

4 CABLE BUNDLE THROUGH CONCRETE OVER METAL DECKING (3-HR.)
E.3.4 NOT TO SCALE

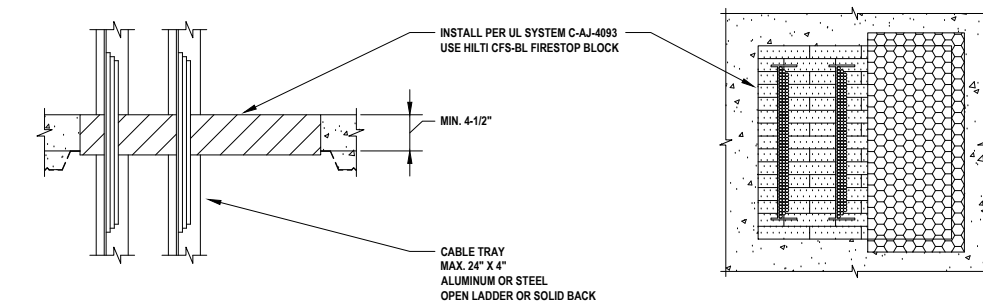

CABLE BUNDLE CONSISTS OF:			
TYPE	MAX.	TYPE	MAX.
COPPER CONDUCTOR CABLE WITH PVC JACKET	7/8" NO. 12 AWG	SINGLE CONDUCTOR POWER CABLE WITH PVC JACKET	500 KCMIL
TELEPHONE CABLE WITH PVC JACKET	300 PAIR NO. 24 AWG	FIBER OPTIC CABLE WITH PVC JACKET	24
SINGLE CONDUCTOR POWER CABLE WITH PVC JACKET	350 KCMIL		

5 MULTIPLE CABLE TRAYS THROUGH CONCRETE OVER METAL DECKING (3-HR.)
E.3.4 NOT TO SCALE

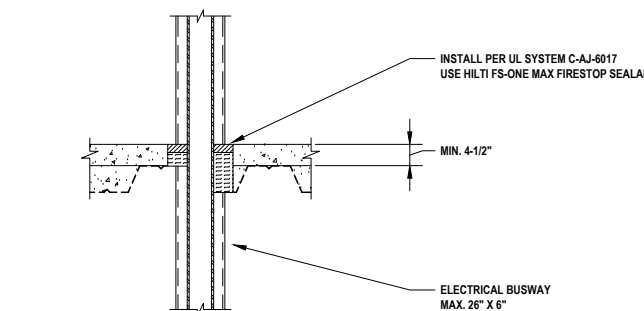

6 ELECTRICAL BUSWAY THROUGH CONCRETE OVER METAL DECKING (3-HR.)
E.3.4 NOT TO SCALE

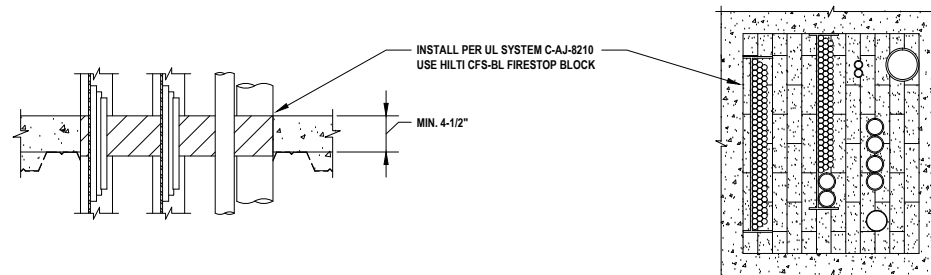

7 MULTIPLE PENETRATIONS THROUGH CONCRETE OVER METAL DECKING (3-HR.)
E.3.4 NOT TO SCALE

JOB NUMBER: _____

CHECKED: _____

ISSUE DATE: _____

REVISIONS: _____

CONTENTS: _____

ELECTRICAL PENETRATIONS CONCRETE OVER METAL DECK 3 HR.

SHEET NAME: _____

E.3.4

SHEET NUMBER: _____

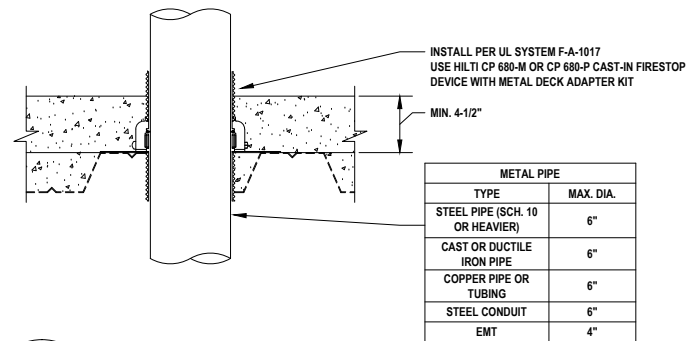

1
E.3.5
METAL PIPE THROUGH CONCRETE OVER METAL DECKING (3-HR.)
NOT TO SCALE

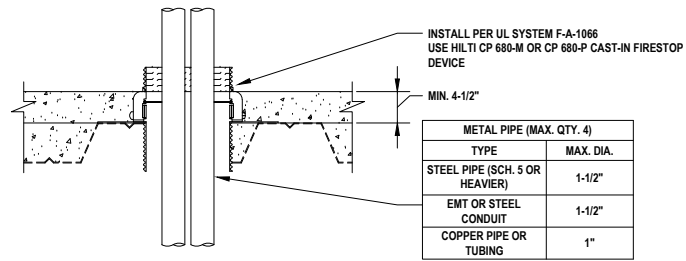

2
E.3.5
MULTIPLE METAL PIPES THROUGH CONCRETE OVER METAL DECKING (3-HR.)
NOT TO SCALE

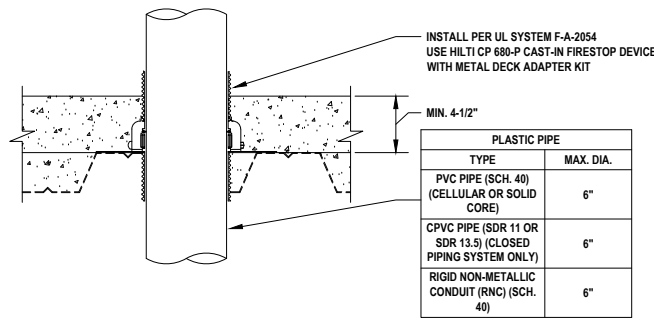

3
E.3.5
PLASTIC PIPE THROUGH CONCRETE OVER METAL DECKING (3-HR.)
NOT TO SCALE

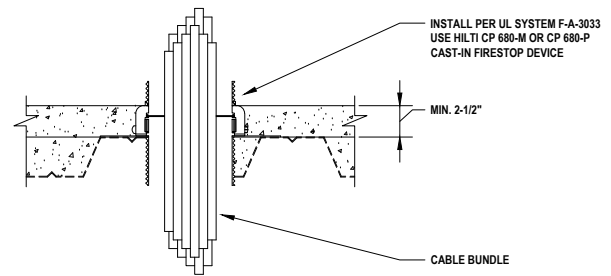

4
E.3.5
CABLE BUNDLE THROUGH CONCRETE OVER METAL DECKING (3-HR.)
NOT TO SCALE

CABLE BUNDLE CONSISTS OF:			
TYPE	MAX.	TYPE	MAX.
TELEPHONE CABLE WITH PVC JACKET	300 PAIR NO. 24 AWG	FIBER OPTIC CABLE (24 FIBER)	1/2" DIA.
POWER CABLE WITH PVC JACKET	750 KCMIL	METAL-CLAD CABLE	3/4" NO. 12 AWG
POWER CABLE WITH PVC JACKET	7/8" NO. 12 AWG		

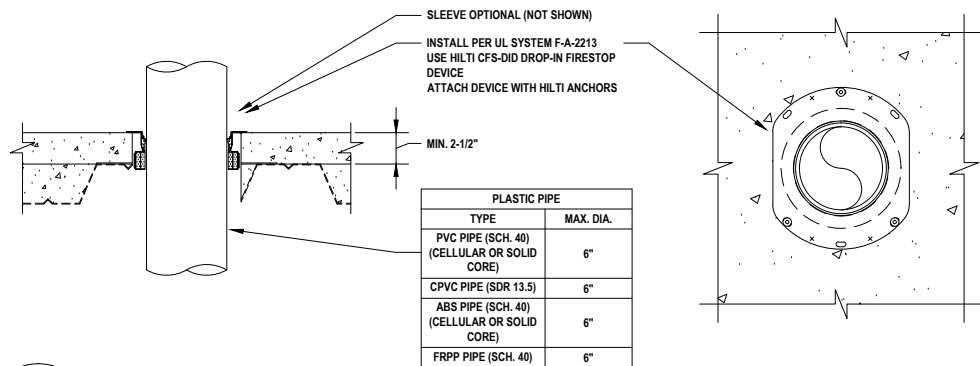

5
E.3.5
PLASTIC PIPE THROUGH CONCRETE OVER METAL DECKING (3-HR.)
NOT TO SCALE

Notes:

- Refer to the following specifications for firestopping.
 - 07 84 00 Firestopping
 - 07 84 13 Penetration Firestopping
 - 22 00 00 Plumbing
 - 23 00 00 HVAC
 - 26 00 00 Electrical
 - 27 06 37 Communication

For Quality Control requirements, refer to the Quality Control portion of the specification.

2. Details shown are typical details, containing general information only. Always refer to the full UL system detail for complete system requirements. If field conditions do not match requirements of details, approved alternate details shall be utilized. Design requirements, field conditions and dimensions need to be verified for compliance with the details, including but not limited to the following:

- * Fire Rating (F-Rating)
- * Temperature Rating (T-Rating)
- * Leakage Rating (L-Rating)
- * Water Rating (W-Rating)
- * Annular Space
- * Percent Fill
- * Movement
- * Type and thickness of fire-rated construction.

3. If alternate details matching the field conditions are not available, manufacturer's engineering judgment drawings are acceptable. Contact Hilti Inc. for alternative systems or Engineering Judgment (800-879-8000) Drawings shall follow the International Firestop Council (IFC) Guidelines for Evaluating Firestop Systems Engineering Judgments.

4. References:
- * 2013 Underwriter's Laboratories Fire Resistance Directory, Volumes 1 & 2
 - * NFPA 101 Life Safety Code
 - * NFPA 70 - National Electric Code
 - * All governing local and regional building codes
5. Firestop System installation must meet requirements of ASTM E-814 (UL 1479) tested assemblies that provide a fire rating equal to that of construction being penetrated.
6. All rated through-penetration assemblies shall be prominently labeled with a Hilti Firestop Label equipped with a QR code with the following information:
- * Warning! - Do Not Disturb
 - * Through Penetration Firestop System
 - * UL System # * Product(s) used
 - * Hourly Rating (F-Rating)
 - * Installation Date
 - * Contractor's Name

7. For outlet boxes requiring protection, use only Wall Opening Protective Materials, category CLIV as classified by Underwriter's Laboratories, Fire Resistance Directory (Volume 1.)

<Notes to designer (delete this note after reading and replace with title block information)>
 1. Any modification to these details could result in an application/system not meeting the UL or Intertek Classification or the intended temperature or fire ratings.
 2. Details shown are up to date as of February 2015.
 3. For additional information on the details, refer to the most current "Underwriter's Laboratories Fire Resistance Directory (volume 2.)"

JOB NUMBER: _____

CHECKED: _____

ISSUE DATE: _____

REVISIONS: _____

CONTENTS: _____

ELECTRICAL PENETRATIONS
CONCRETE OVER METAL DECK
3 HR.

SHEET NAME: _____

E.3.5

SHEET NUMBER: _____