



Classified by
Underwriters Laboratories, Inc.
to UL 1479 and CAN/ULC-S115

System No. F-A-5032

FA 5032

ANSI/UL1479 (ASTM E814)	CAN/ULC S115
F Rating — 2 Hr	F Rating — 2 Hr
T Rating — 0 and 1 Hr (See Item 3)	FT Rating — 0 and 1 Hr (See Item 3)
	FH Rating — 2 Hr
	FTH Rating — 0 and 1 Hr (See Item 3)

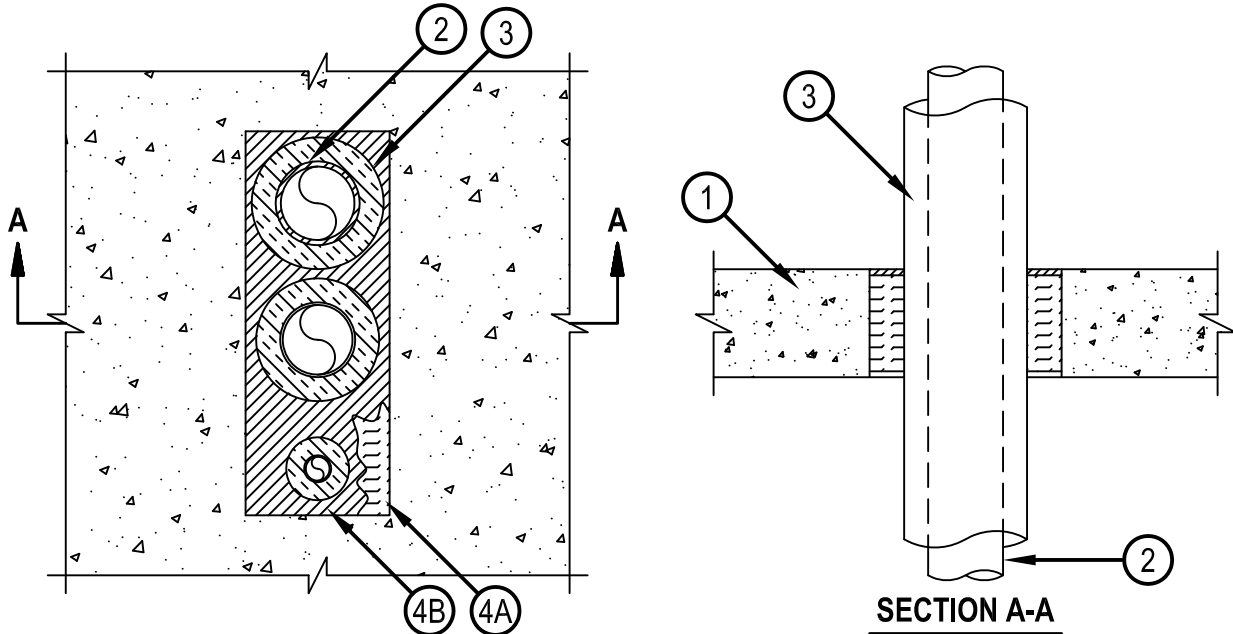

- Floor or Wall Assembly — Min 4-1/2 in. (114 mm) thick reinforced normal weight (100-150 pcf or 1600-2400 kg/m³) concrete. Max size of opening is 96 in.2 (619 mm²) with a max dimension of 16 in. (406 mm).
- Through-Penetrants — Max three metallic penetrants installed within the opening. Penetrants to be rigidly supported on both sides of the floor assembly. The following types and sizes of metallic penetrants may be used:
 - Steel Pipe — Nom 3 in. diam (or smaller) Schedule 5 (or heavier) steel pipe.
 - Iron Pipe — Nom 3 in. diam (or smaller) cast or ductile iron pipe.
 - Copper Tubing — Nom 3 in. diam (or smaller) Type L (or heavier) copper tubing.
 - Copper Pipe — Nom 3 in. diam (or smaller) Regular (or heavier) copper pipe.
- Pipe Covering* — One of the following types of pipe covering shall be used on each penetrant:
 - Nom 1 in. (25 mm) thick (or thinner) hollow cylindrical heavy density glass fiber units jacketed on the outside with an all service jacket. Longitudinal joints sealed with metal fasteners or factory-applied self-sealing lap tape. Transverse joints secured with metal fasteners or with butt strip tape supplied with the product. The annular space between the insulated penetrants and between the insulated penetrants and the periphery of the opening shall be min 1/4 in. (6 mm) to max 2 in.
See Pipe and Equipment Covering Materials (BRGU) category in the Building Materials Directory for names of manufacturers. Any pipe covering material meeting the above specifications and bearing the UL Classification Marking with a Flame Spread Index of 25 or less and a Smoke Developed Index of 50 or less may be used.
 - Tube Insulation - Plastics+ — Nom 1 in. thick acrylonitrile butadiene/polyvinyl chloride (AB/PVC) flexible foam furnished in the form of tubing. The annular space between the insulated penetrants and between the insulated penetrants and the periphery of the opening shall be min 1/4 in. (6 mm) to max 2 in.
See Plastics (QMFZ2) category in the Plastics Recognized Component Directory for names of manufacturers. Any Recognized Component tube insulation material meeting the above specifications and having a UL 94 Flammability Classification of 94-5A may be used.

When pipe covering is less than 1 in. (25 mm) thick, the T Rating is 0 Hr.



Hilti Firestop Systems

Reproduced by HILTI, Inc. Courtesy of
Underwriters Laboratories, Inc.
December 27, 2013

4. Firestop System — The firestop system shall consist of the following:

- A. Packing Material — Min 4 in. (102 mm) thickness of 4 pcf (64 kg/m³) mineral wool batt insulation tightly packed into the opening as a permanent form. Packing material to be recessed from top surface of floor to accommodate the required thickness of fill material.
- B. Fill, Void or Cavity Material — Sealant* — Min 1/4 in. (6 mm) thickness of fill material applied within the annulus flush with the top surface of the floor.

HILTI CONSTRUCTION CHEMICALS, DIV OF HILTI INC — CP604, CFS-S SIL GG or CFS-S SIL SL Sealant

*Bearing the UL Classification Mark

