



All loading and design criteria supplied by customer is assumed accurate. Only the stated Design Assumptions were considered, and must be verified by the responsible Engineer of Record (EOR). The basis of Hilti component and connection design is the published data in the current Hilti Technical Guide, including material and cross-section properties, allowable load values, factors of safety, methods of calculation, and limiting factors. The EOR must verify suitability for any specific application, and the capacity of the supportive structure to receive the shown configuration and associated reaction loads. Modification to components and/or design may alter performance and must be evaluated by the EOR.

TYPICAL DETAIL TYPE:
CABLE TRAY SUPPORT

TYPICAL DETAIL DESCRIPTION:
CANTILEVER SINGLE - VERTICAL

DESIGNED BY: KL	REVIEWED BY: AJV
DRAWN BY: GAB	ISSUE DATE: 02 JAN 15

REVISIONS:

NO.	DESCRIPTION:	DATE:
A	ORIGINAL ISSUE	02 JAN 15

TYPICAL DETAIL NOMENCLATURE:
CT-C08-S

DRAWING NUMBER: 01	SHEET: 1/1
-----------------------	---------------

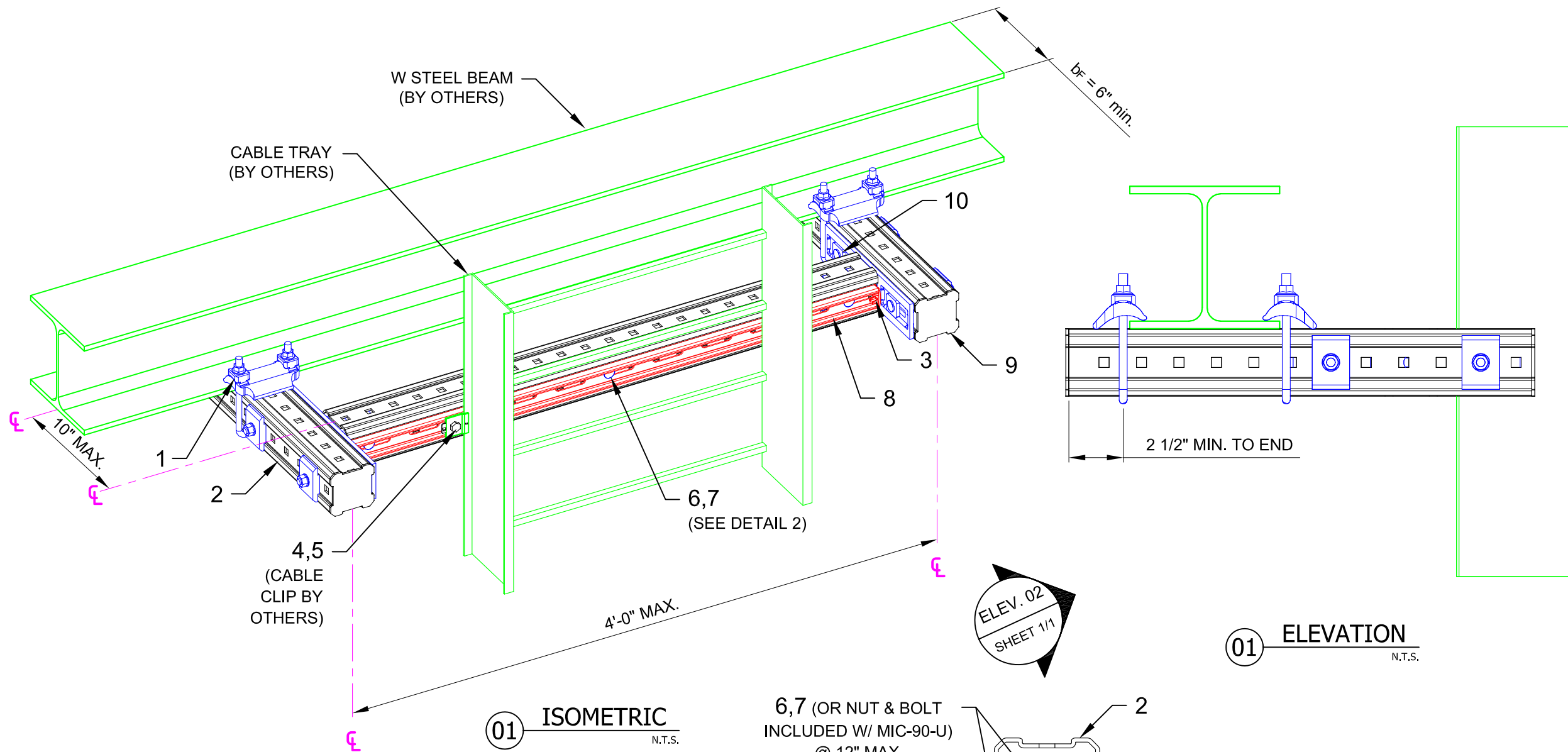

ELEV. 02
SHEET 1/1

01 ELEVATION
N.T.S.

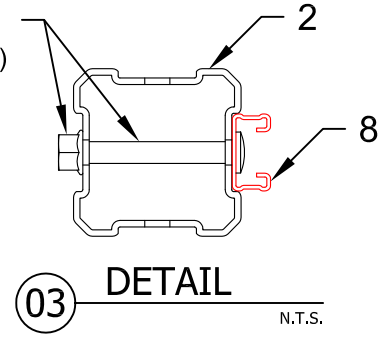

03 DETAIL
N.T.S.

No.	Unit Qty	Unit	Description	Box Qty	# Boxes Needed	Item No.
1	4	EA	BEAM CLAMP MI-DGC 90	4	1	233860
2	AS REQ'D	EA	GIRDER MI-90 3M	1	AS REQ'D	304798
3	2	EA	CHANNEL END CAP MEK RED	50	1	244886
4	2	EA	HEX HEAD BOLT HDG 0.375in x LENGTH AS REQUIRED	VARIES	AS REQ'D	SPECIAL
5	2	EA	WING NUT MQM-F3/8"-F	25	1	304136
6	1	EA	ONEHAND SCREW MIA-OH90	10	1	304889
7	1	EA	PREVAIL TORQUE HEX NUT M12-F-SL-WVS 3/4"	100	1	382897
8	AS REQ'D	EA	STRUT MS-1316-12/HDG 9'-10" (3M)	1	AS REQ'D	407569
9	4	EA	GIRDER END CAP MIA-EC90	25	1	432077
10	2	EA	CONNECTOR MIC-90-L	2	1	304805

- NOTE(S):
- PRELIMINARY NOT FOR CONSTRUCTION
 - DESIGN ASSUMPTIONS:
 - DESIGN LOADS (STATIC, U.N.O.):
DL: 1200 lbs.
 - LATERAL LOADS NOT CONSIDERED**
 - CORROSION RESISTANCE REQD.: HDG
 - REFER TO COMPONENT MANUFACTURER'S IFUs FOR REQUIRED INSTALLATION INFO.
 - E.O.R. MUST BE NOTIFIED OF ANY DEVIATIONS FROM EXISTING/ NEW SUBSTRATE CONDITIONS SHOWN HEREIN TO VALIDATE ACCEPTANCE OF THIS HILTI DESIGN PRIOR TO INSTALLATION.
 - MAX. ASSUMED DEAD LOAD OUT-PLANE ECCENTRICITY = 4 IN.