



All loading and design criteria supplied by customer is assumed accurate. Only the stated Design Assumptions were considered, and must be verified by the responsible Engineer of Record (EOR). The basis of Hilti component and connection design is the published data in the current Hilti Technical Guide, including material and cross-section properties, allowable load values, factors of safety, methods of calculation, and limiting factors. The EOR must verify suitability for any specific application, and the capacity of the supportive structure to receive the shown configuration and associated reaction loads. Modification to components and/or design may alter performance and must be evaluated by the EOR.

TYPICAL DETAIL TYPE:
PIPE SUPPORT

TYPICAL DETAIL DESCRIPTION:
GOALPOST - MULTI

DESIGNED BY: KL	REVIEWED BY: AJV
--------------------	---------------------

DRAWN BY: HAM	ISSUE DATE: 09 DEC 14
------------------	--------------------------

REVISIONS:

NO.	DESCRIPTION:	DATE:
A	ORIGINAL ISSUE	09 DEC 14

TYPICAL DETAIL NOMENCLATURE:
P-GP41-C

DRAWING NUMBER: 01	SHEET: 1/1
------------------------------	----------------------

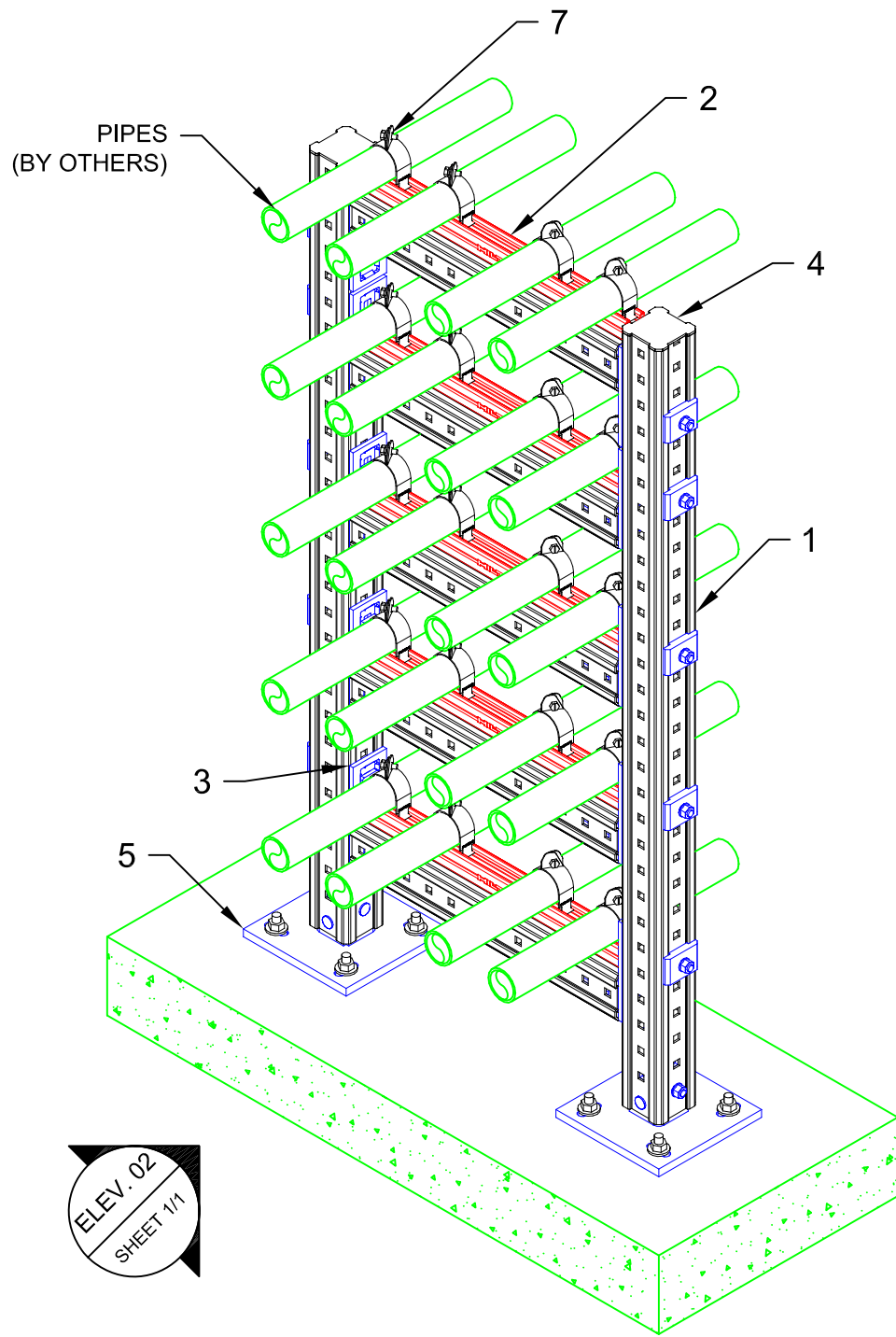

01 ISOMETRIC
N.T.S.

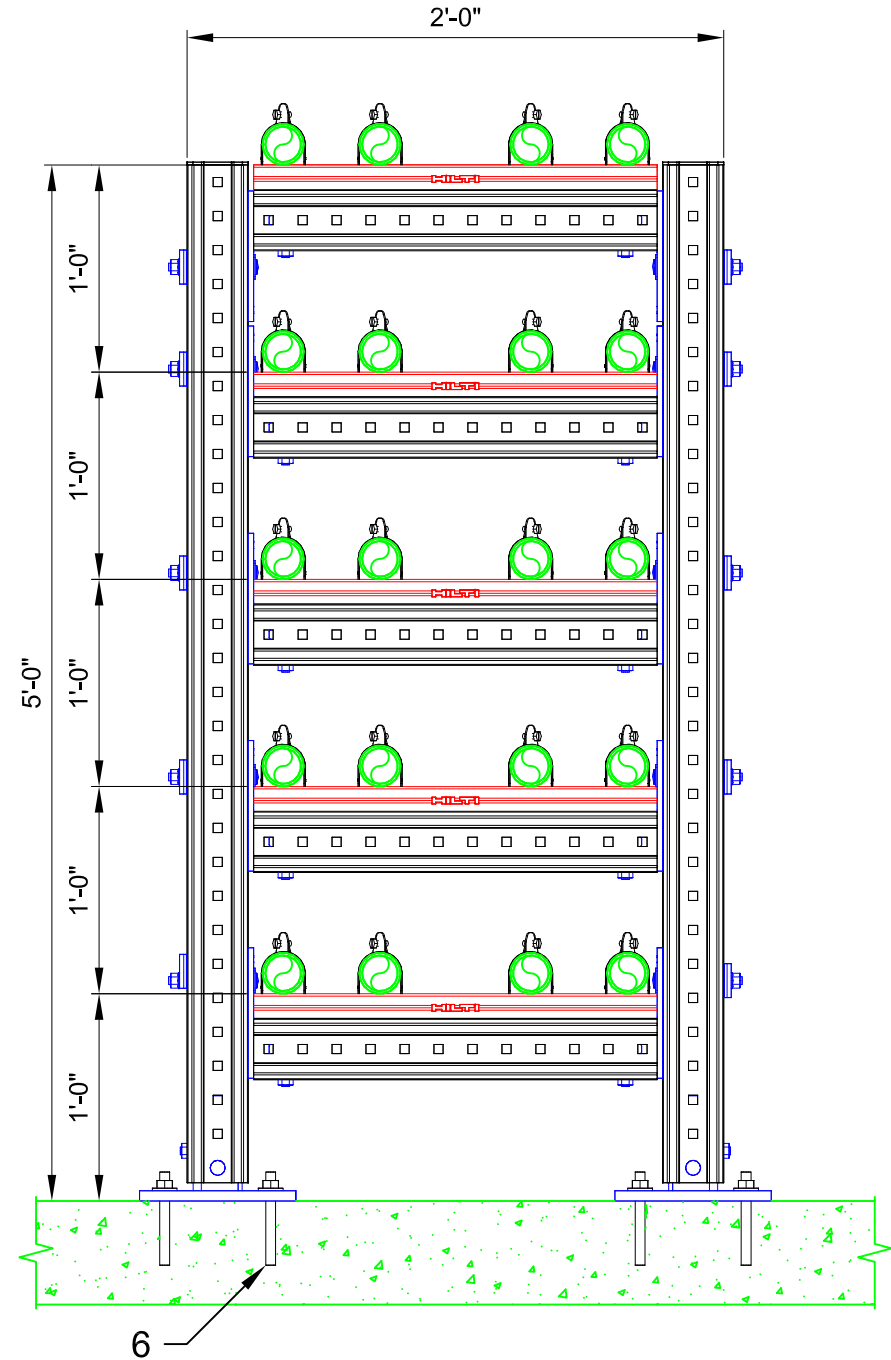

02 ELEVATION
N.T.S.

No.	Unit Qty	Unit	Description	Box Qty	# Boxes Needed	Item No.
1	AS REQ'D	EA	GIRDER MI-90 3M	1	AS REQ'D	304798
2	AS REQ'D	EA	STRUT HS-158-12/HDG 10'	1	AS REQ'D	407570
3	10	EA	CONNECTOR MIC-90-U	4	3	304803
4	2	EA	GIRDER END CAP MIA-EC90	25	1	432077
5	2	EA	CONNECTOR MIC-C90-D CONCRETE	2	1	304827
6	8	EA	USE KB3 OR KB-TZ AS APPROPRIATE	VARIES	VARIES	VARIES
7	20	EA	MH-R45 STRUT CLAMP	VARIES	VARIES	VARIES

NOTE(S):

- PRELIMINARY NOT FOR CONSTRUCTION
- DESIGN ASSUMPTIONS:
 - DESIGN LOADS (STATIC, U.N.O.):
DL: SELF WEIGHT
PIPE LOAD: 2" SCH. 40 PIPE WITH 2 1/2" INSULATION.
 - LATERAL LOADS NOT CONSIDERED
 - BUILDING CODE: IBC 2012
 - CORROSION RESISTANCE REQ'D.: HDG
 - MAX. SUPPORT SPACING = 10'-0"
- ALL LOADS ASSUMED TO ACT AT CENTER OF PIPE(S), U.N.O.
- REFER TO COMPONENT MANUFACTURER'S IFUs FOR REQUIRED INSTALLATION INFO.
- E.O.R. MUST BE NOTIFIED OF ANY DEVIATIONS FROM EXISTING/ NEW SUBSTRATE CONDITIONS SHOWN HEREIN TO VALIDATE ACCEPTANCE OF THIS HILTI DESIGN PRIOR TO INSTALLATION.

\\hilti.com\us\TEAM\Installations\Projects\TYPICAL LIBRARY\PIPING (P)\CAD\IP-GP41-C.dwg, 12/29/2014, 3:02:02 PM

