



Classified by  
Underwriters Laboratories, Inc.  
to UL 2079 and CAN/ULC-S115

# System No. HW-D-0872

HWD 0872

ANSI/UL2079	CAN/ULC S115
Assembly Ratings — 1 and 2 Hr (See Item 2)	F Rating — 1 and 2 Hr (See Item 2)
Nominal Joint Widths — 7/8, 1 or 1-5/8 In (See Item 3)	F Rating — 1 and 2 Hr (See Item 2)
Class II or III Movement Capabilities — 62% Compression or Extension, 86 Compression or Extension or 92% Compression only (See Item 3)	FH Rating — 1 and 2 Hr (See Item 2)
L Rating at Ambient —1 CFM/Lin Ft (See Item 1C)	FTH Rating — 1 and 2 Hr (See Item 2)
L Rating at 400°F — Less than 1 CFM/Lin Ft (See Item 1C)	Nominal Joint Widths – 22, 25 or 41 mm (See Item 3)
	Class II or III Movement Capabilities — 62% Compression or Extension, 86 Compression or Extension or 92% Compression only (See Item 3)
	L Rating at Ambient —1.55 L/s/m (See Item 1C)
	L Rating at 204°F — Less than 1.55 L/s/m (See Item 1C)

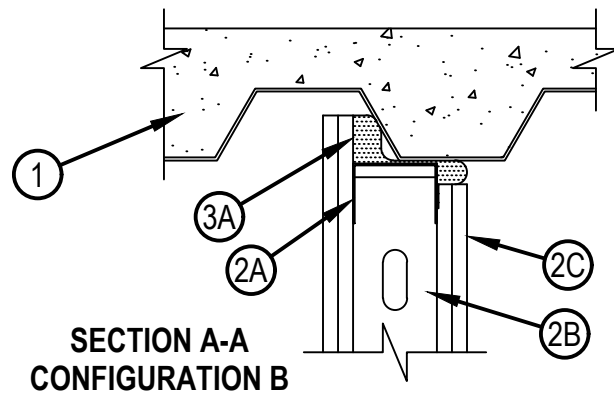
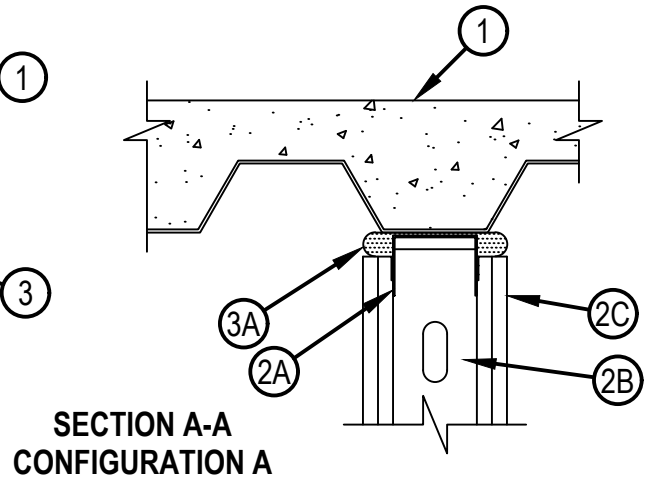
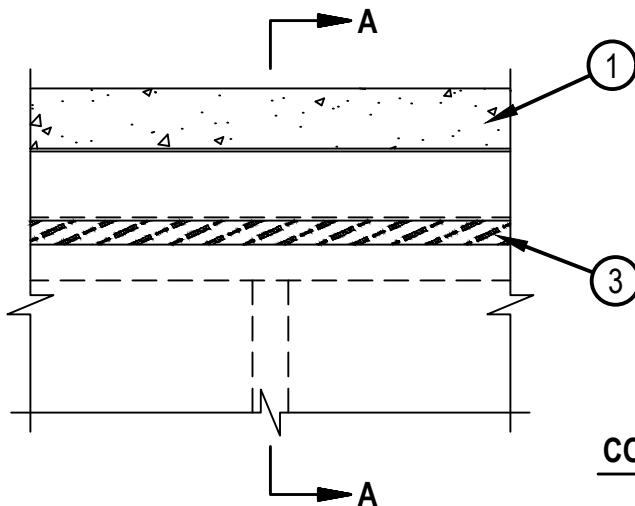

Reproduced by HILTI, Inc. Courtesy of  
Underwriters Laboratories, Inc.  
November 18, 2024

1. Floor Assembly — The fire-rated fluted steel deck/concrete floor assembly shall be constructed of the materials and in the manner described in the individual D700 or D900 Floor-Ceiling Design in the UL Fire Resistance Directory. The hourly fire rating of the floor assembly shall be equal to or greater than the hourly fire rating of the wall assembly. The floor assembly shall include the following construction features:
  - A. Steel Floor And Form Units\* — Max 3 in. (76 mm) deep galv fluted floor units.
  - B. Concrete — Min 2-1/2 in. (64 mm) thick reinforced (100-150 pcf or 1600-2400 kg/m<sup>3</sup>) concrete, as measured from the top plane of the floor units.
  - C. Spray-Applied Fire Resistive Materials\* — (Optional, Not Shown) — Prior to the installation of the steel ceiling runners and Fill, Void or Cavity Material (Item 3A), the steel floor units may be sprayed with the thickness of material specified in the individual D700 or D900 Series Design. L Ratings are not applicable when spray-applied fire resistive material is used.
    - GCP APPLIED TECHNOLOGIES INC — Types MK-6-HY or MK-10HB
    - ISOLATEK INTERNATIONAL — Type 300

## Configuration A

2. Wall Assembly — The 1 or 2 h fire-rated gypsum board /steel stud wall assembly shall be constructed of the materials and in the manner specified in the individual U400, V400 or W400 Series Wall and Partition Design in the UL Fire Resistance Directory and shall include the following construction features:
  - A. Steel Floor and Ceiling Runners — Floor and ceiling runners of wall assembly shall consist of min No. 25 gauge galv steel channels sized to accommodate steel studs (Item 2B). Flange height of ceiling runner shall be min 1/4 in. (6 mm) greater than max extended joint width. Ceiling runner installed parallel to direction of fluted steel deck, centered under the valley of the deck and secured to steel deck with masonry anchors or steel fasteners spaced max 24 in. (610 mm) OC. Secure ceiling runner after optional spray-applied fire resistive material is used.
    - A1. Light Gauge Framing\* — Slotted Ceiling Runner — As an alternate to the ceiling runner in Item 2A, slotted ceiling runner to consist of galv steel channel with slotted flanges sized to accommodate steel studs (Item 2B). Slotted ceiling runner secured to steel deck with masonry anchors or steel fasteners spaced max 24 in. (610 mm) OC. Secure ceiling runner after optional spray-applied fire resistive material is used.
      - CEMCO, LLC — CST
      - CLARKDIETRICH BUILDING SYSTEMS — Types SLT, SLT-H
      - MARINO/WARE, DIV OF WARE INDUSTRIES INC — Type SLT
      - METAL-LITE INC — The System
      - SCAFCO STEEL STUD MANUFACTURING CO — Slotted Track
      - TELLING INDUSTRIES L L C — True-Action Deflection Track
  - B. Steel Attachment Clips — (Optional — Not Shown) — When spray applied fire resistive material is used, ceiling runner may be secured to deck with Z-shaped clips formed from min 1 in. (25 mm) long strips of min 20 ga galv steel. Length of clips should not exceed the width (thickness) of the wall. Clips to be sized to extend through the thickness of the spray-applied fire-resistive material on the bottom of the steel deck with 1-1/2 or 2 in. (38 or 51 mm) long upper and lower legs. Legs of clips fastened to valleys of steel deck (prior to application of spray-applied fire-resistive materials) and top of ceiling runner with steel masonry anchors, steel fasteners or welds. Clips spaced max 24 in. (610 mm) OC.
  - C. Studs — Steel studs to be min 3-1/2 in. (89 mm) wide. Studs cut 3/4 to 1 in. (19 to 25 mm) less in length than assembly height with bottom nesting in and resting on floor runner and with top nesting in ceiling runner without attachment. When slotted ceiling runner (Item 2A1) is used, steel studs secured to slotted ceiling runner with No. 8 by 1/2 in. (13 mm) long wafer head steel screws at mid-height of slot on each side of wall. Stud spacing not to exceed 24 in. (610 mm) OC.
  - D. Gypsum Board\* — For 1 hr assembly, one layer of 5/8 in. (16 mm) thick gypsum board is required in the individual Wall and Partition Design. For 2 hr assembly, two layers of 5/8 in. (16 mm) thick gypsum board is required in the individual Wall and Partition Design. The screws attaching the gypsum board to studs at the top of the wall shall be located 3-1/2 in. (89 mm) to 5-1/2 in. (138 mm) below the bottom edge of the ceiling runner.

The hourly ratings of the joint system are dependent on the hourly rating of the wall.



3. Joint System — Max separation between the bottom of steel floor unit, or spray-applied fire resistive material, and top of wall is 7/8 in. (22 mm), 1 in (25 mm), or 1-1/2 in (38 mm). See Item 3-Table 1 for more details. The joint system consists of the following:
- A. Fill, Void or Cavity Material\* — Top Track Seal — Factory supplied foam seal installed over the ceiling runner (Item 2A) prior to attachment to underside of floor assembly or steel attachment clips (Item 2B) in accordance with the installation instructions.  
HILTI CONSTRUCTION CHEMICALS, DIV OF HILTI INC — CFS-TTS MD OS or CFS-TTS MD 600 Firestop Top Track Seal

## Configuration B

2. Wall Assembly — The 1 or 2 h fire-rated gypsum board /steel stud wall assembly shall be constructed of the materials and in the manner specified in the individual U400, V400 or W400 Series Wall and Partition Design in the UL Fire Resistance Directory and shall include the following construction features:
- A. Steel Floor and Ceiling Runners — Floor and ceiling runners of wall assembly shall consist of min No. 25 gauge galv steel channels sized to accommodate steel studs (Item 2B). Flange height of ceiling runner shall be min 1/4 in. (6 mm) greater than max extended joint width. Ceiling runner installed parallel to direction of fluted steel deck, offset under the valley of the deck to extend a max 1-1/2 in. (38 mm) into area of flute and secured to steel deck with masonry anchors or steel fasteners spaced max 24 in. (610 mm) OC. Secure ceiling runner after optional spray-applied fire resistive material is used.
  - A1. Light Gauge Framing\* — Slotted Ceiling Runner — As an alternate to the ceiling runner in Item 2A, slotted ceiling runner to consist of galv steel channel with slotted flanges sized to accommodate steel studs (Item 2B). Slotted ceiling runner secured to steel deck masonry anchors or steel fasteners spaced max 24 in. (610 mm) OC. Secure ceiling runner after optional spray-applied fire resistive material is used.  
CEMCO, LLC — CST  
CLARKDIETRICH BUILDING SYSTEMS — Types SLT, SLT-H  
MARINO/WARE, DIV OF WARE INDUSTRIES INC — Type SLT  
METAL-LITE INC — The System  
SCAFCO STEEL STUD MANUFACTURING CO — Slotted Track  
TELLING INDUSTRIES L L C — True-Action Deflection Track
  - B. Steel Attachment Clips — (Optional — Not Shown) — When spray applied fire resistive material is used, ceiling runner may be secured to deck with Z-shaped clips formed from min 1 in. (25 mm) long strips of min 20 ga galv steel. Length of clips should not exceed the width (thickness) of the wall. Clips to be sized to extend through the thickness of the spray-applied fire-resistive material on the bottom of the steel deck with 1-1/2 or 2 in. (38 or 51 mm) long upper and lower legs. Legs of clips fastened to valleys of steel deck (prior to application of spray-applied fire-resistive materials) and top of ceiling runner with steel masonry anchors, steel fasteners or welds. Clips spaced max 24 in. (610 mm) OC.
  - C. Studs — Steel studs to be min 3-1/2 in. (64 mm) wide. Studs cut 3/4 to 1 in. (19 to 25 mm) less in length than assembly height with bottom nesting in and resting on floor runner and with top nesting in ceiling runner without attachment. When slotted ceiling runner (Item 2A1) is used, steel studs secured to slotted ceiling runner with No. 8 by 1/2 in. (13 mm) long wafer head steel screws at mid-height of slot on each side of wall. Stud spacing not to exceed 24 in. (610 mm) OC.
  - D. Gypsum Board\* — For 1 hr assembly, one layer of 5/8 in. (16 mm) thick gypsum board is required in the individual Wall and Partition Design. For 2 hr assembly, two layers of 5/8 in. (16 mm) thick gypsum board is required in the individual Wall and Partition Design. The screws attaching the gypsum board to studs at the top of the wall shall be located 3-1/2 in. (89 mm) to 5-1/2 in. (138 mm) below the bottom edge of the ceiling runner.

The hourly ratings of the joint system are dependent on the hourly rating of the wall.

3. Joint System — When max separation between the bottom of steel floor unit, or spray-applied fire resistive material, and top of wall is 7/8 in. (22 mm), 1 in (25 mm), or 1-1/2 in (38 mm). See Table 1 for more details. The joint system consists of the following :



# System No. HW-D-0872

HW-D-0872

Table 1

Max Nom Joint Width, In. (mm)	Max Movement Capabilities, (% of nominal)		Max Movement, in. (mm)
7/8 (22)	Compression	86%	3/4 (19)
	Extension	86%	5/8 (16)
1 (25)	Compression	62%	5/8 (16)
	Extension	62%	5/8 (16)
1-5/8 (41)	Compression	92%	1-1/2 (38)
	Extension	0%	N/A

As an alternative to the movement percentages above, the joint system may move freely without restriction to the percentage of movement within the range of a min 1/8 in. (3.2 mm) to max 1-5/8in. (41 mm) joint width.

A. Fill, Void or Cavity Material\* — Top Track Seal — Factory supplied foam seal installed over the ceiling runner (Item 2A) prior to attachment to underside of floor assembly or steel attachment clips (Item 2B) in accordance with the installation instructions. Where ceiling runner is offset under the flute, Top Track Seal to be pushed upwards into flute as drywall runs past.

HILTI CONSTRUCTION CHEMICALS, DIV OF HILTI INC — CFS-TTS MD OS or CFS-TTS MD 600 Firestop Top Track Seal

\* Indicates such products shall bear the UL or cUL Certification Mark for jurisdictions employing the UL or cUL Certification (such as Canada), respectively.



**Hilti Firestop Systems**

Reproduced by HILTI, Inc. Courtesy of  
Underwriters Laboratories, Inc.  
November 18, 2024