



Classified by
Underwriters Laboratories, Inc.
to UL 1479

System No. C-AJ-2835

ANSI/UL1479 (ASTM E814)

F Rating - 1, 2, or 3 Hr (See Item 2)

T Rating - 0, 1-1/2, and 2 Hr (See Item 1A and 2)

L Rating at Ambient — Less Than 1 CFM/ft²

L Rating at 400°F — Less Than 1 CFM/ft²

CAJ 2835

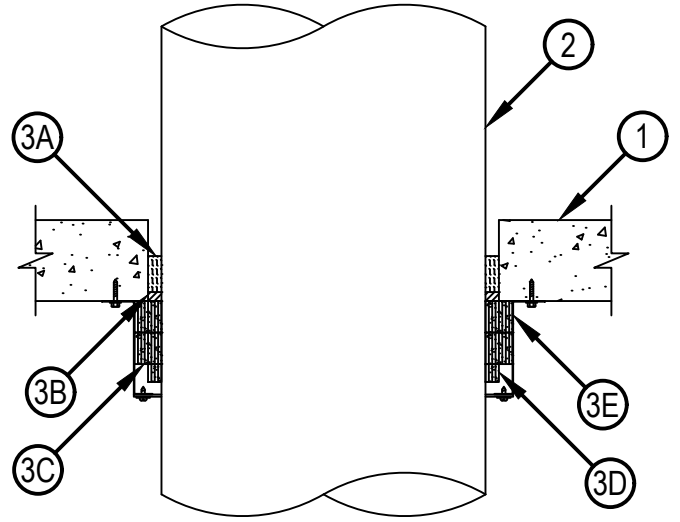
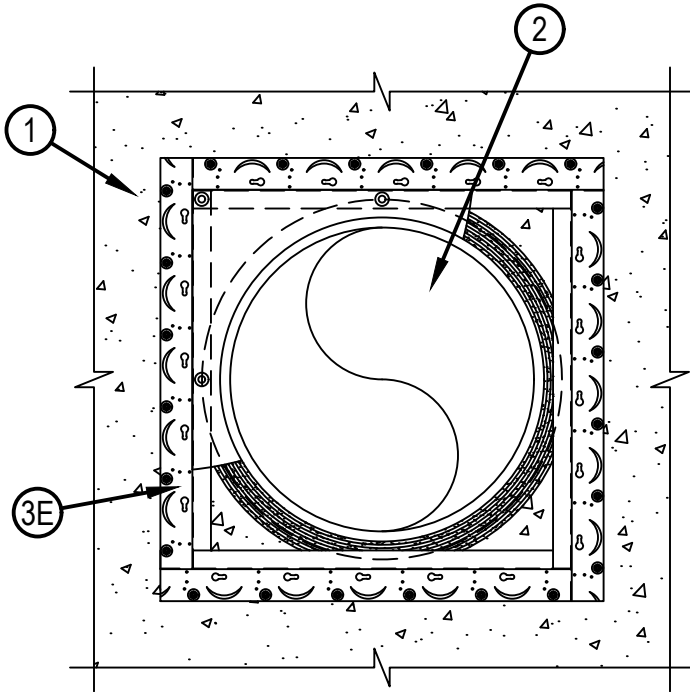

Reproduced by HILTI, Inc. Courtesy of
Underwriters Laboratories, Inc.
August 07, 2019

System No. C-AJ-2835

System tested with a minimum pressure differential of 2.5 Pa between the exposed and unexposed surfaces with the higher pressure on the exposed side.

1. Floor or Wall Assembly — Min 4-1/2 in. (114 mm) thick reinforced lightweight or normal weight (100-150 pcf) (1600-2400 kg/m³) concrete. Wall may also be constructed of any UL Classified Concrete Blocks*. Max diameter of opening is 20 in. (508 mm). See Concrete Blocks (CAZT) in the Fire Resistance Directory for names of manufacturers.
- 1A. Sleeve — (Optional. Not Shown) - Nom 20 in. (508 mm) diam (or smaller) Schedule 10 steel pipe sleeve, or min. 24 ga sheet metal sleeve, or Schedule 40 PVC pipe sleeve cast or grouted into floor or wall assembly, flush with floor or wall surfaces. The F and T Ratings are 0 Hr when the steel pipe sleeve is used. Otherwise, the F and T Ratings of the firestop system are as specified in the table below.
2. Through Penetrants — One nonmetallic pipe to be installed concentrically or eccentrically within the firestop system. Annular space between pipe and periphery of opening to be min 1/4 in. (6 mm) to max 1-1/2 in. (38 mm). The F and T ratings, and the firestop method are dependent on the size and/or type of pipe as shown in the tables below. The following types and sizes of nonmetallic pipes may be used:
 - A. Polyvinyl Chloride (PVC) Pipe — Nom 18 in. (457 mm) diam (or smaller) Schedule 40 solid core PVC for use in closed (process or supply) or vented (drain, waste or vent) piping systems.
 - B. Chlorinated Polyvinyl Chloride (CPVC) Pipe — Nom 18 in. (457 mm) diam (or smaller) Schedule 40 CPVC pipe for use in closed (process or supply) or vented (drain, waste or vent) piping systems.
 - C. Chlorinated Polyvinyl Chloride (CPVC) Pipe — Nom 18 in. (457 mm) diam (or smaller) Schedule 40 Corzan CPVC pipe for use in closed (process or supply) or vented (drain, waste or vent) piping systems.
 - D. Chlorinated Polyvinyl Chloride (CPVC) Pipe — Nom 18 in. (457 mm) diam (or smaller) Schedule 80 Corzan CPVC pipe for use in closed (process or supply) piping systems only.

Pipe Type	Nom. Pipe Diam., In. (mm)	F-Rating, Hr.	T-Rating, Hr.
PVC	Greater than 14 (356)	2	2
PVC	14 (356) or smaller	3	2-3/4
CPVC	Greater than 14 (356)	2	1-1/2
CPVC	14 (356) or smaller	3	1-1/2

Nom. Pipe Diam., In. (mm)	Required number of wrap strips (Item 3C)	Required number of attachment clips (Item 3F)
Greater than 14 (356)	3C2	3F2
14 (356) or smaller	3C1	3F1



3. Firestop System — The firestop system shall consist of the following:

A. Packing or Forming Materials — Min 2 in. (51 mm) thickness of min 4 pcf (64 kg/m³) mineral wool batt insulation tightly packed into the opening as a permanent form. Packing material to be recessed from the bottom surface of floor or both surfaces of wall to accommodate the required thickness of sealant (Item 3B).

B. Fill, Void or Cavity Material* — Min 1/2 in. (13 mm) thickness of sealant applied within the annulus, flush with bottom surface of floor or with both surfaces of wall. In systems with sleeves (Item 1A), for L Rating, a bead of sealant shall be applied at sleeve to concrete interface at top or bottom side of floor or both sides of wall.

HILTI CONSTRUCTION CHEMICALS, DIV OF HILTI INC — FS-ONE MAX Intumescent Sealant

C1. Fill, Void or Cavity Material* — For nonmetallic pipes 14 in. (356 mm) or smaller. Wrap Strip - Two stacks of six layers of intumescent wrap strip are continuously wrapped around the pipe with ends held in place with masking or aluminum tape. Butted ends in successive layers shall be offset. Wrap strip butted tightly against bottom surface of floor or both surfaces of wall.

C2. Fill, Void or Cavity Material* — For nonmetallic pipes greater than 14 in. (356 mm). Wrap Strip - Two stacks of eight layers of intumescent wrap strip are continuously wrapped around the pipe with ends held in place with masking or aluminum tape. Butted ends in successive layers shall be offset. Wrap strip butted tightly against bottom surface of floor or both surfaces of wall.

HILTI CONSTRUCTION CHEMICALS, DIV OF HILTI INC — CP648-E W45/1-3/4" Firestop Wrap Strip

D. Fill, Void or Cavity Material* — Wrap Strip - Four layers of intumescent wrap strip are continuously wrapped around the pipe with ends held in place with masking or aluminum tape. Butted ends in successive layers shall be offset. Wrap strip butted tightly against double stack of wrap strip (Item 3C) at bottom surface of floor or both surfaces of wall.

HILTI CONSTRUCTION CHEMICALS, DIV OF HILTI INC — CP48-E W25/1" Firestop Wrap Strip

E. Firestop Device* — Z-frame (four pieces) cut to a length equal to the OD of the double stack wrap strip and installed in point contact with the wrap strip (Item 3C) at the four sides to form a 5 in. (127 mm) deep rectangular enclosure around the wrap strip material. The 2 in. (51 mm) leg of each piece of Z-frame fastened to the floor or wall through each of the round 3/8 in. (9.5 mm) diam pre-made holes in outer edge of Z-frame with 3/16 in. (4.8 mm) by 1-1/4 in. (32 mm) long steel concrete screw anchors in conjunction with 1 in. (25 mm) diam fender washers. The four pieces of Z-frame are butted at the four corners. Z-frame enclosure installed at bottom of floor or both sides of wall.

HILTI CONSTRUCTION CHEMICALS, DIV OF HILTI INC — CP 675T Z-Frame

F1. Attachment Clip* — (Not shown) At each corner of the Z frame enclosure the butting pieces of Z-frame shall be secured with one CP 643N attachment clip centered at mid-depth of Z-frame. Each leg of clip is attached to the Z-frame with a min 3/4 in. (19 mm) long steel screw and 3/4 in. (19 mm) diam. steel washer.

HILTI CONSTRUCTION CHEMICALS, DIV OF HILTI INC — CP 643N anchor clips

F2. Attachment Clip* — (Not shown) At each corner of the Z frame enclosure the butting pieces of Z-frame shall be secured with two CP 643N attachment clips, one centered at mid-depth of Z-frame, and one located at end of Z-frame furthest from the floor or wall assembly. Each leg of clip is attached to the Z-frame with a min 3/4 in. (19 mm) long steel screw and 3/4 in. (19 mm) diam. steel washer.

HILTI CONSTRUCTION CHEMICALS, DIV OF HILTI INC — CP 643N anchor clips

G1. Cover Plate — (Not shown) A min 24 ga sheet steel cover secured to the 1 in. (25 mm) legs of Z-frame to close off the bottom of the enclosure. Cover plate to be two pieces with a 1 in. (25 mm) overlap at the seam. For pipes 12 in. (305 mm) or smaller, cover plate secured with min three 3/4 in. (19 mm) long sheet metal screws equally spaced at each side, with a fastener at each corner and at each seam, For pipes greater than 12 in. (305 mm) cover plate secured with min five 3/4 in. (19 mm) long sheet metal screws and min 3/4 in. (19 mm) diam steel washers equally spaced at each side, with a fastener at each corner and at each seam. Cover plate sized to the OD of the Z-frame enclosure and to within 1/4 in. (6 mm) of the penetrant contour.

G2. Composite Sheet* — (Not shown) As an alternate to the cover plate (Item 3G1), cover plate may consist of Hilti CFS-COS Firestop Composite Sheet. Composite sheet cover plate secured to the 1 in. (25 mm) legs of Z-frame to close off the bottom of the enclosure. Cover plate to be two pieces with a 1 in. (25 mm) overlap at the seam. Cover plate secured with min five 3/4 in. (19 mm) long sheet metal screws and min 3/4 in. (19 mm) diam steel washers equally spaced at each side, with a fastener at each corner and at each seam, Cover plate sized to the OD of the Z-frame enclosure and to within 1/4 in. (6 mm) of the penetrant contour.

HILTI CONSTRUCTION CHEMICALS, DIV OF HILTI INC — Hilti CFS-COS Firestop Composite Sheet

* Indicates such products shall bear the UL or cUL Certification Mark for jurisdictions employing the UL or cUL Certification (such as Canada), respectively.

