

Design No. HI/BPF 120-23
Perimeter Fire Barrier System
 Hilti, Inc.
Edge of Slab QuickSeal CFS-EOS QS
ASTM E2307, CAN/ULC-S115

Table 1

	Edge of Slab Quick Seal, CFS-EOS QS
F-Rating	2 Hour
T-Rating	52 Minute
L-Rating	< 2.0 SCFM/LF
Cycling (Class IV) Vertical	-7.5%

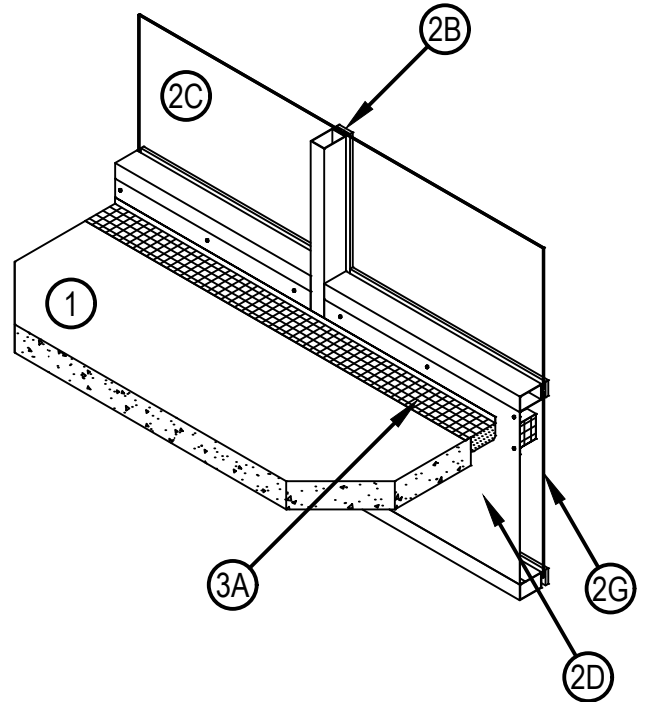
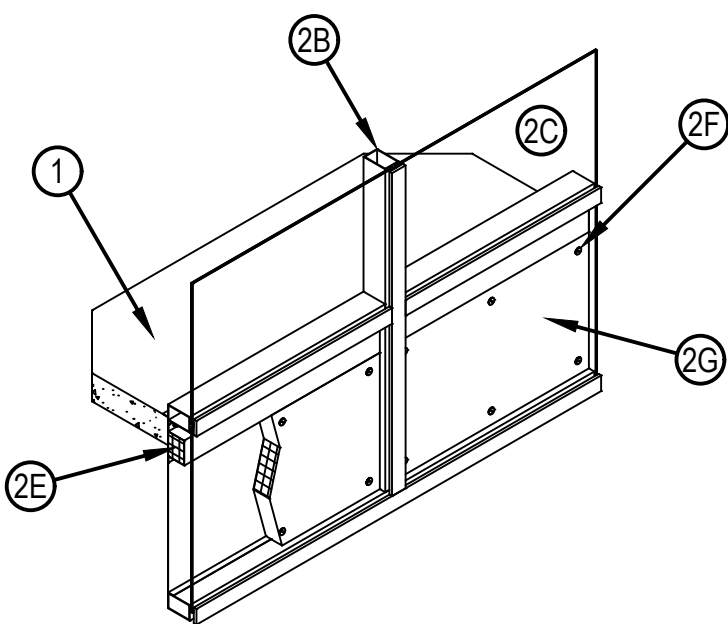

Table 2

Product	Allowable Joint Width	
	Minimum	Maximum
CFS-EOS QS Small	1-1/2 in.	3 in.
CFS-EOS QS Medium	2 in.	4 in.
CFS-EOS QS Large	3 in.	5 in.

1. **CONCRETE FLOOR ASSEMBLY:** 2 hour rated concrete floor assembly made from either lightweight or normal weight concrete with a density of 100 to 150 pcf, having a min. thickness of 4-1/2 in. at the joint face. When a longitudinal recess (blockout) is required to contain an architectural joint system, increase concrete floor assembly thickness to maintain a min. thickness of 4-1/2 in. and accommodate depth of blockout formed in the concrete: blockout width unrestricted.
2. **CURTAIN WALL ASSEMBLY:** The curtain wall assembly shall incorporate the following construction features:
 - A. **MOUNTING ATTACHMENT (Not Shown)** – Attach aluminum framing (Item 2B) to the structural framing with min. 1/2 in. thick aluminum anchor brackets according to the curtain wall manufacturer's instructions. Connect the mounting attachments to the joint face of the concrete floor assembly (Item 1) according to the curtain wall manufacturer's instructions.
 - B. **ALUMINUM FRAMING** – Use hollow rectangular aluminum extruded tubing with min. overall dimensions of 0.100 in. thick, 5-1/4 in. deep and 2-1/2 in. wide. Locate mullions (vertical aluminum framing) min. 60 in. oc and transoms (horizontal aluminum framing) min. 32-1/2 in. oc. For the spandrel region, locate the bottom of the upper transom (horizontal aluminum framing) min. 3 in. above the concrete floor assembly (Item 1).
 - C. **GLASS PANELS** – Size and install into aluminum framing (Item 2B) in accordance with the curtain wall manufacturer's instructions. Use min. 1/4 in. thick, clear, heat strengthened (HS) or tempered glass with height and width sized accordingly for the aluminum framing (Item 2B) spacing. OC spacing shall allow glass to be secured to the aluminum framing (Item 2B) between the notched shoulders. Secure glass panels with a thermal break (rubber extrusion), pressure bar (aluminum extrusion), min. 1/4-20 × 5/8 in. long screws, and a snap face (aluminum extrusion).
 - D. **STEEL BACKPAN:** Install min 22 Ga, galvanized steel backpan with 2 in. lip flush with interior face of framing and attached to mullions and the transom above the floor-line with 3/4 in. long No 10 self-drilling, self-tapping steel screws spaced a max. of 8 in. oc. Apply pressure sensitive aluminum foil faced taped around the periphery of the backpan sealing to the adjacent aluminum framing.
 - E. **BACKPAN STIFFENER:** Secure min. 18 Ga, galvanized, hat-shaped, stiffener placed horizontally, stuffed with nominal 3 in thick 8 pcf density mineral wool batt insulation (faced or unfaced), and measuring 4 in. wide by 3 in. deep and having 1 in. flanges secured to the backpan with No. 10 sheet metal screws max. 12 in. oc. Position the top of the lower flange of the stiffener 2 in. below the top of the floor.
 - F. **IMPALING PINS:** Size and install min. 12 GA steel pins a min 1/2 in. longer than the thickness of the curtain wall insulation. Attach pins to the back pan (Item 2D) in at max. 12 in. oc vertical and horizontal spacing.
 - G. **CURTAIN WALL INSULATION:** Use only mineral wool certified by an approved third party, bearing a listing label, meeting the following requirements:
 - Fill the cavity of the steel backpan (Item 2D) with a min. 3 in. thick, 8 pcf, mineral wool curtain wall insulation, tightly fit, compress at least 1/8 in. in all directions.
3. **PERIMETER JOINT PROTECTION:** Do not exceed a 5 in. nominal joint width (joint width at installation) (per Table 2). Incorporate the following construction features for the perimeter joint protection (also known as perimeter fire barrier system):
 - A. **CERTIFIED MANUFACTURER:** Hilti Corporation
CERTIFIED PRODUCT: Edge of Slab QuickSeal CFS-EOS QS
Compress the appropriately sized Edge of Slab QuickSeal product (per Table 2) into the perimeter joint opening. Remove paper from adhesive and adhere flaps to top side of concrete floor and front face of backpan. Splices (butt joints) in the length of Edge of Slab QuickSeal are to be tightly compressed together (minimum 1/4 in. compression). At each vertical mullion, center and install an additional 12 in. length strip of CFS-EOS QS up against bottom of perimeter joint protection with flaps (facing down) adhered to concrete floor and back pan.
 - B. **CERTIFIED MANUFACTURER:** Hilti Corporation
 - C. **CERTIFIED PRODUCT:** Edge of Slab Waterstop CFS-EOS WS
(Optional, Not Shown) Use only Hilti Corporation CFS-EOS WS bearing an Intertek Certified Label. Apply 2mm wet thickness over any seams and overlap a min 1 in. onto Edge of Slab QuickSeal, the adjacent curtain wall assembly and concrete floor slab assembly.



D. JOINT COVER (Not Shown)

Install minimum 0.05 in. (1.29 mm) thick aluminum L-shaped joint cover extending the entire length of the Edge of Slab QuickSeal CFS-EOS QS. The vertical leg of the joint cover must be a minimum of 2.5 in. high and the horizontal leg must extend a minimum 1 in. beyond the joint. Joint cover to be continuously connected to transom via integrated keying function per curtain wall manufacturer's instructions.

* Before testing, the test specimen was subjected to -3/8 in. (-7.5%) vertical movement based on a 5 in. nominal joint width through a min. of 100 times at 30 cpm, followed by a min. of 400 cycles at 10 cpm.



Hilti Firestop Systems

Reproduced by HILTI, Inc.
Courtesy of Intertek Group
December 27, 2019

Intertek