



Classified by
Underwriters Laboratories, Inc.
to CAN/ULC-S115

System No. F-A-2347

F Rating — 2 Hr

FT Ratings — 0 and 1/2 Hr (See Item 3)

FH Rating — 0 Hr

FTH Rating — 0 Hr



FA 2347

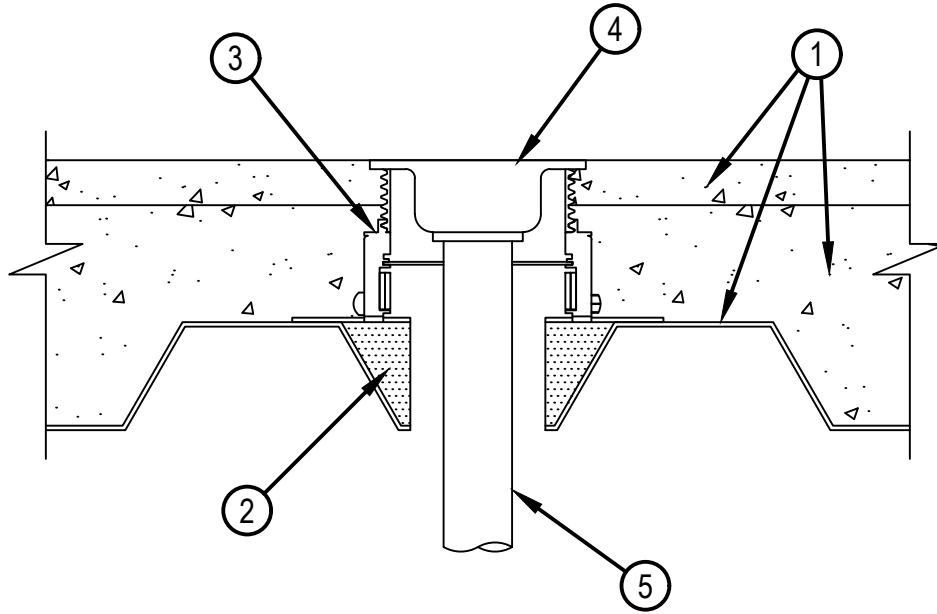

Hilti Firestop Systems

Reproduced by HILTI, Inc. Courtesy of
Underwriters Laboratories, Inc.
December 08, 2020

System No. F-A-2347



FA 2347

System tested with a pressure differential of 50 Pa between the exposed and the unexposed surfaces with the higher pressure on the exposed side.

1. Floor Assembly — The fire rated concrete and steel floor assembly shall be constructed of the materials and in the manner specified in the individual D700 or D900 Series designs in the UL Fire Resistance Directory and as summarized below:
 - A. Concrete — Min 3-3/4 in. (95 mm) thick reinforced lightweight or normal weight (100-150 pcf or 1600-2400 kg/m³) concrete.
 - A1. Concrete — Min 2-1/2 in. (64 mm) thick reinforced lightweight or normal weight (100-150 pcf or 1600-2400 kg/m³) concrete, with a min 1-1/4 in. (32 mm) thickness of concrete or grout topping extending min 24 in. (610 mm) beyond periphery of drain flange.
 - B. Steel Floor and Form Units* — Max 3 in. (76 mm) deep galv steel fluted units as specified in the individual Floor-Ceiling Design.
 - C. Spray-Applied Fire Resistive Material — (Optional. Not Shown.) Steel floor units may be sprayed with the type and thickness of fire resistive material indicated in the individual D700 Series Design.UNITED STATES MINERAL PRODUCTS CO, DBA ISOLATEK INTERNATIONAL — Type 300
GCP APPLIED TECHNOLOGIES INC — MK-6/HY+
2. Firestop Device* — Cast in place firestop device platform installed prior to concrete placement in floor assembly. The CFS-CID MD PLT firestop device platform is screwed to the fluted deck with one fastener at each corner in accordance with manufacturer installation instructions. The firestop device platform is sized for nominal 2 and 3 in. (51 and 76 mm) deep fluted decks.
HILTI CONSTRUCTION CHEMICALS, DIV OF HILTI INC — CFS-CID MD PLT W2" and W3"
3. Firestop Device* — Cast in place firestop device installed over firestop device platform prior to concrete placement in floor assembly. The CFS-CID MD Firestop Device is set onto and screwed to the firestop device platform (Item 2) in accordance with manufacturer installation instructions. The 2.5" height devices are intended for a 2.5 in. (64 mm) concrete topping over the fluted deck and shall be used with the Hilti provided extension. The 4" height devices are intended for concrete toppings greater than 2.5 in. (64 mm) thick. The device extension shall be cut to project min 1/2 in. (13 mm) above the top surface of the firestop device such that it extends to the underside of the drain body flange.
HILTI CONSTRUCTION CHEMICALS, DIV OF HILTI INC — CFS-CID MD PX 4"/2.5", CFS-CID MD PX 4"/4", CFS-CID MD P 4"/2.5" and CFS-CID MD P 4"/4"
The FT Rating is 0 hr when the CFS-CID-MD P device is used and 1/2 hr when the CFS-CID-MD PX device is used.
4. Shower/Floor Drain — Flanged PVC body drain sized to accommodate drain pipe. Flange of drain shall be embedded within the concrete floor (Item 1A) or concrete/grout topping (Item 1A1). Drain provided with polished brass or chromed steel shower drain or floor drain strainer grouted into drain body. PVC drain body inserted into firestop device with the drain flange resting on the top edge of device or device extension prior to pour of concrete floor or installation of topping material. PVC drain body cemented to drain piping (Item 5).
5. Drain Piping — Nom 2 in. (51 mm) diam Schedule 40 solid core polyvinyl chloride (PVC) drain piping and fittings use in vented (drain, waste or vent) piping system.

* Indicates such products shall bear the UL or cUL Certification Mark for jurisdictions employing the UL or cUL Certification (such as Canada), respectively.



Reproduced by HILTI, Inc. Courtesy of
Underwriters Laboratories, Inc.
December 08, 2020