



All loading and design criteria supplied by customer is assumed accurate. Only the stated Design Assumptions were considered, and must be verified by the responsible Engineer of Record (EOR). The basis of Hilti component and connection design is the published data in the current Hilti Technical Guide, including material and cross-section properties, allowable load values, factors of safety, methods of calculation, and limiting factors. The EOR must verify suitability for any specific application, and the capacity of the supportive structure to receive the shown configuration and associated reaction loads. Modification to components and/or design may alter performance and must be evaluated by the EOR.

PROJECT NAME:

TYPICAL DETAILS

SERVICE REQUEST DESCRIPTION:

CABLE TRAY CANTILEVER STEEL

DESIGNED BY:
AJV

REVIEWED BY:
ISE

DRAWN BY:
GAB

ISSUE DATE:
22 DEC 14

REVISIONS:

NO.	DESCRIPTION:	DATE:
A	ORIGINAL ISSUE	22 DEC 14
-		
-		
-		
-		
-		
-		
-		
-		
-		
-		
-		
-		
-		
-		
-		
-		
-		
-		
-		

SERVICE REQUEST NUMBER:

TD-CT-C05-S

DRAWING NUMBER:

01

SHEET:

1/1

Maximum "L1" (in)	Allowable Vertical Load (lbs)	Allowable Transverse Load (lbs)	Allowable Longitudinal Load (lbs)
48	214	0	0
48	214	64	0
48	214	0	64
60	142	0	0
60	142	42	0
60	142	0	42
72	107	0	0
72	107	32	0
72	107	0	32

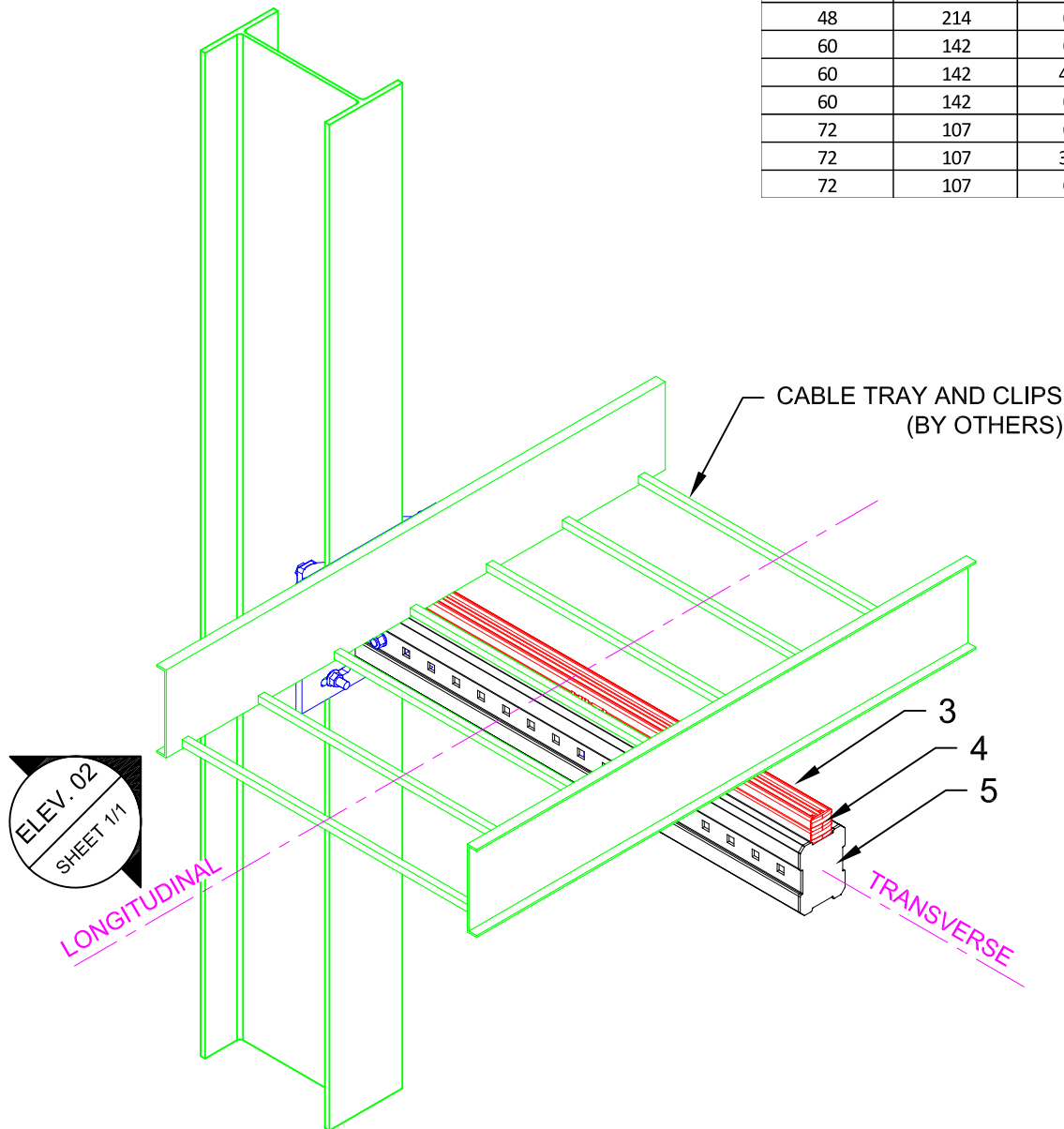

01 ISOMETRIC
N.T.S.

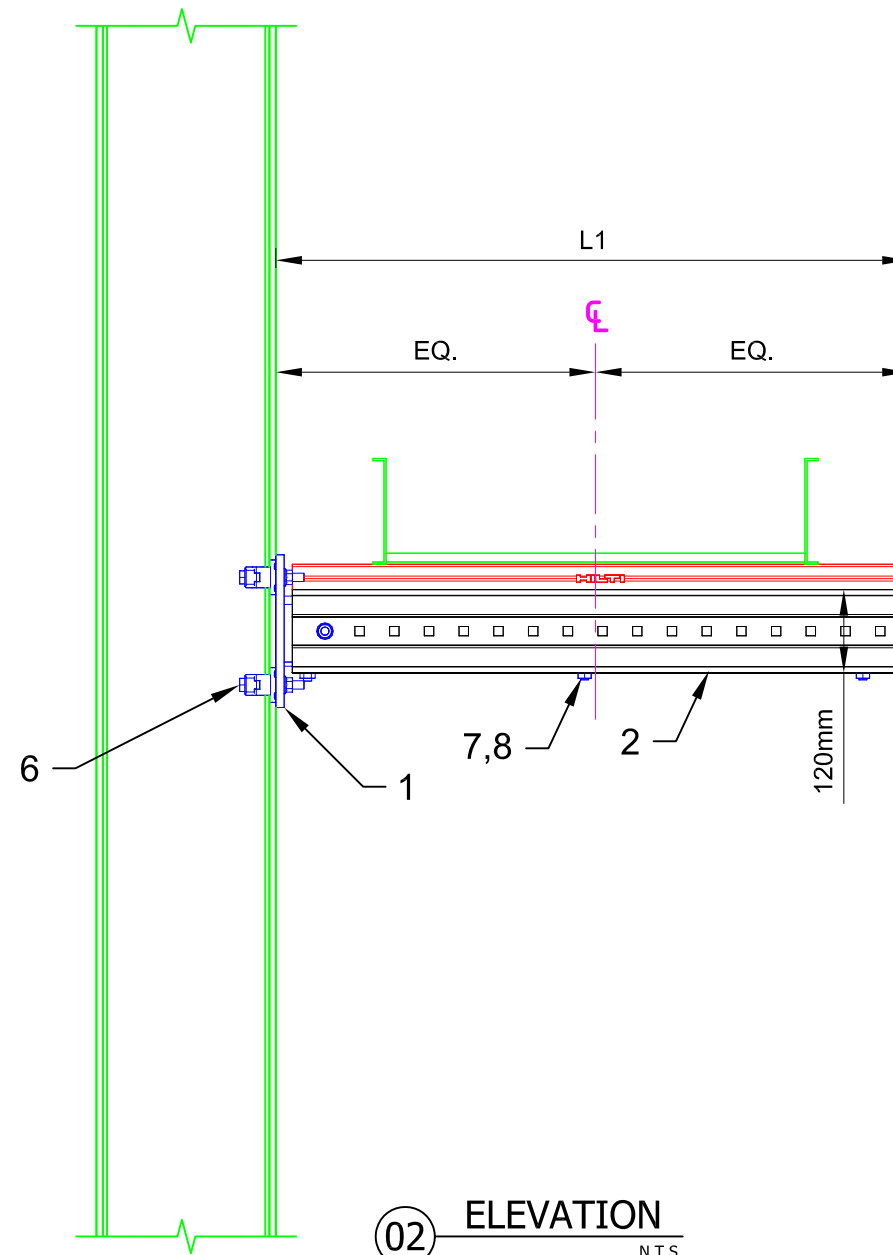

02 ELEVATION
N.T.S.

MIC-S120-X

Beam Width Table

X	'B' Width	Item No.
A	2.9 to 6.5	304818
B	6.5 to 9.2	304819
C	9.2 to 11.8	304820

MIC-SX-MA

Beam Width Table

X	'B' Width	Item No.
A	2.9 to 6.5	304815
B	6.5 to 9.2	304816
C	9.2 to 11.8	304817

No.	Unit Qty	Unit	Description	Box Qty	# Boxes Needed	Item No.
1	1	EA	CONNECTOR MIC-S120-X STEEL (SEE TABLE)	2	1	VARIABLE
2	AS REQ'D	EA	GIRDER MI-120 3M	1	AS REQ'D	304800
3	AS REQ'D	EA	STRUT HS-158-12/HDG 10'	1	AS REQ'D	407570
4	2	EA	CHANNEL END CAP MEK RED	50	1	244886
5	1	EA	GIRDER END CAP MIA-EC120	25	1	432078
6	4	EA	BEAM CLAMP MI-SGC-M12	16	1	233859
7	3	EA	ONEHAND SCREW MIA-OH120	10	1	304890
8	3	EA	PREVAIL TORQUE HEX NUT M12-F-SL-WS 3/4"	100	1	382897

NOTE(S):

1. ALLOWABLE LOADS CONSIDER APPROPRIATE LOAD FACTORS AND LOAD COMBINATIONS PER APPLICABLE CODES AND STANDARDS.
2. ALL LOADS ASSUMED TO ACT AT HORIZONTAL \bar{C} OF CABLE TRAY WHICH IS SITTING DIRECTLY ON TOP OF MI GIRDER, U.N.O.
3. VERTICAL LOAD APPLIED WITH ONE HORIZONTAL LOAD AT A TIME.
4. CABLE TRAY HORIZONTAL OFFSET FROM MI POST \bar{C} = 0"