



Classified by
Underwriters Laboratories, Inc.
to UL 2079 and CAN/ULC-S115

System No. FF-D-1013

Assembly Rating - 2 Hr

Nominal Joint Width - 3-1/2 in.

Class II Movement Capabilities - 14% Compression or Extension

FFD 1013

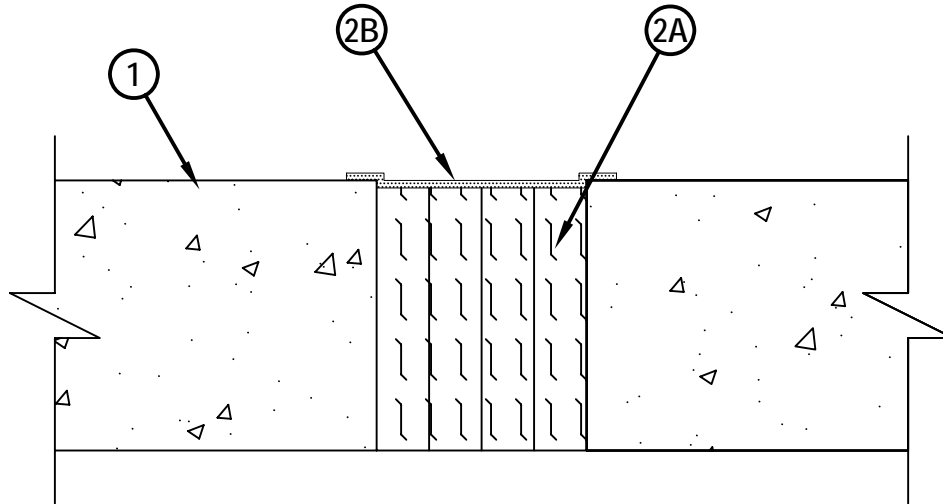

1. Floor Assembly — Min 4-1/2 in. (114 mm) thick reinforced lightweight or normal weight (100 - 150 pcf or 1600 - 2400 kg/m³) structural concrete.
2. Joint System — Max width of joint (at time of installation of joint system) is 3-1/2 in. (89 mm). The joint system is designed to accommodate a max 14 percent compression or extension from its installed width. The joint system shall consist of the following:
 - A. Packing Material — Min 4 pcf (64 kg/m³) mineral wool batt insulation installed in joint opening as a permanent form. Pieces of batt cut to min width of 4-3/8 in. (111 mm) and installed edge-first into joint opening, parallel with joint direction, such that batt sections are compressed min 42 percent in thickness and that the compressed batt sections are recessed from top surface of the floor as required to accommodate the required thickness of fill material. Adjoining lengths of batt to be tightly-butted with butted seams spaced min 24 in. (610 mm) apart along the length of the joint.
 - B. Fill, Void or Cavity Material* — Sealant — Min 1/8 in. (3.2 mm) wet thickness of fill material applied within the joint, flush with top surface of floor and lapping a min 1/2 in. (13 mm) onto the top surface of the floor.

HILTI CONSTRUCTION CHEMICALS, DIV OF HILTI INC — CP672 Firestop Spray or CFS-SP WB Firestop Joint Spray

*Bearing the UL Classification Mark



Hilti Firestop Systems

Reproduced by HILTI, Inc. Courtesy of
Underwriters Laboratories, Inc.

June 04, 2010