

Design No. HI/BPF 120-10
PERIMETER FIRE BARRIERS
Firestop Joint Spray CFS-SP WB
ASTM E 2307

Table 1.

	Firestop Joint Spray CFS-SP WB	Silicone Joint Spray CFS-SP SIL
F-Rating	2 Hour	2 Hour
T-Rating	45 Minute	45 Minute
Application Thickness	1/8 in. wet film (1/16 in. dry)	2 mm (0.08 in.) wet film

Static Joint
L-Rating <1.0 SCFM/LF at Ambient Conditions

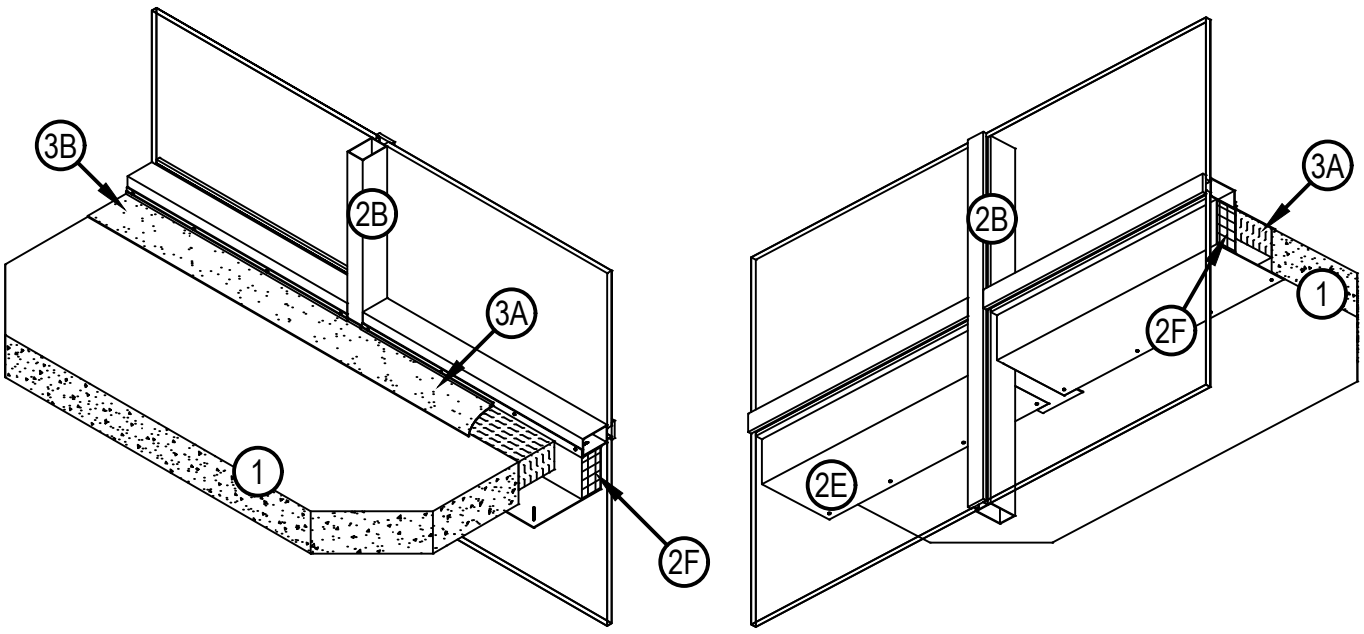

1. CONCRETE FLOOR ASSEMBLY: 2 hour rated concrete floor assembly made from either lightweight or normal weight concrete with a density of 100 to 150 pcf, having a min. thickness of 6 in. at the joint face. When a longitudinal recess (blockout) is required to contain an architectural joint system, increase concrete floor assembly thickness to maintain a min. thickness of 6 in. and accommodate depth of blockout formed in the concrete: blockout width unrestricted.
2. CURTAIN WALL ASSEMBLY: The curtain wall assembly shall incorporate the following construction features:
 - A. Mounting Attachment (Not shown): Attach aluminum framing (Item 2B) to the structural framing according to the curtain wall manufacturer's instructions. Connect the mounting attachments to the joint face of the concrete floor assembly (Item 1) according to the curtain wall manufacturer's instructions.
 - B. Aluminum Framing: Use hollow rectangular aluminum extruded tubing with min. overall dimensions of 0.100 in. thick, 4 in. high and 2-1/2 in. wide. Locate mullions (vertical aluminum framing) min. 60 in. oc. Locate the transom (horizontal aluminum framing) such that the bottom surface of the transom is at the same height as the top surface of the floor assembly.
 - C. Glass Panels: Sized and installed into aluminum framing (Item 2B) in accordance with the curtain wall manufacturer's instructions. Use min. 1/4 in. thick, clear, heat strengthened (HS) or tempered glass with a max. width and height less than the aluminum framing (Item 2B) oc spacing. OC spacing shall allow glass to be secured to the aluminum framing (Item 2B) between the notched shoulders. Secure glass panels with a thermal break (rubber extrusion), pressure bar (aluminum extrusion), min. 1/4-20 by 5/8 in. long screws, and a snap face (aluminum extrusion).
 - D. Aluminum Anchor Brackets (Not shown): Use min. 1/2 in. thick aluminum anchor brackets to serve as part of the mounting attachment (Item 2A) rigidly secured to the aluminum framing (Item 2B) and the concrete floor assembly (Item 1).
 - E. Galvanized Sheet Metal Pan: Attach 18 GA galvanized steel section to the aluminum framing with No. 10 self-drilling sheet metal screws at 12 in. oc and to the concrete slab with Hilti Kwik HUS-EZ 1/4 in. x 1 7/8 in. steel concrete anchors, also 12 in. oc. The galvanized steel pan shall be formed such that it has a min. 1 in. lip for which to secure the pan to the aluminum framing, can contain min. 3 in. thick min. 6 in. tall curtain wall insulation (Item 2F), and a bottom leg long enough to overlap the concrete floor assembly min. 1 in. to secure the pan to the floor assembly (Item 1). Install 18 GA galvanized steel plates min. 4-1/2 in. in width, centered at the aluminum mullions such that there is continuous coverage below the joint. Install Hilti CFS-S SIL GG Firestop Silicone along the edges of the metal pan that are in contact with the aluminum members of the curtain wall assembly.
 - F. Curtain Wall Insulation: Fill the cavity of the metal pan (Item 2E) with nominal 3 in. thick, min 6 in. tall, 8 pcf density, mineral wool batt insulation. Tightly fit, compress at least 1/8 in. in all directions. Use only Intertek certified products meeting the above min. requirements.
3. PERIMETER JOINT PROTECTION: Do not exceed a 4 in. nominal joint width (joint width at installation). Incorporate the following construction features for the perimeter joint protection (also known as perimeter fire barrier system):
 - A. Packing Material: Use only mineral wool bearing an Intertek certified product label and meeting the following min. requirements. Insert min. 12 in. long, min. 2 in. tall, 4-pcf density, mineral wool batt insulation packing material compressed into the joint to 25% into bottom of pan centered at each mullion. Use min. 4 in. tall, 4-pcf density, mineral wool batt insulation and cut packing material width to achieve 25% compression when installed in the nominal joint width and use no more than two adjacent strips. Install insulation with the fibers running parallel to the edge of concrete floor assembly (Item 1) and curtain wall assembly (Item 2A). Tightly compress together splices (butt joints) in the lengths of packing material by using min. 1/4 in. compression per piece of packing material. Use only Intertek certified products meeting the above min. requirements. Locate the top surface of the packing material flush with the top surface of the concrete floor assembly (Item 1).
 - B. CERTIFIED MANUFACTURER: Hilti Corporation
CERTIFIED PRODUCT: Firestop Joint Spray CFS-SP WB or Silicone Joint Spray CFS-SP SIL
Fill, Void, or Cavity Material: Apply over the packing material (Item 3A) as discussed below.
Apply at the thickness specified in Table 1 and overlap the material 1/2 in. onto the adjacent curtain wall assembly and concrete floor slab assembly. When the spraying process is stopped and the applied liquid cures to an elastomeric film before application is restarted, overlap the edge of the cured material at least 1/8 in. with the spray. Reference Product Section of the Intertek Directory for more details on the Listed product.