



Classified by
Underwriters Laboratories, Inc.
to UL 2079 and CAN/ULC-S115

System No. HW-D-0084

HWD 0084

ANSI/UL2079	CAN/ULC S115
Assembly Rating — 1 and 2 Hr (See Items 2 & 3)	F Rating — 1 and 2 Hr (See Items 2 & 3)
Nominal Joint Width - 3/4 In.	FT Rating — 1 and 2 Hr (See Items 2 & 3)
Class II Movement Capabilities - 33% Compression or Extension	FH Rating — 1 and 2 Hr (See Items 2 & 3)
	FTH Rating — 1 and 2 Hr (See Items 2 & 3)
	Nominal Joint Width - 3/4 In.
	Class II Movement Capabilities - 33% Compression or Extension

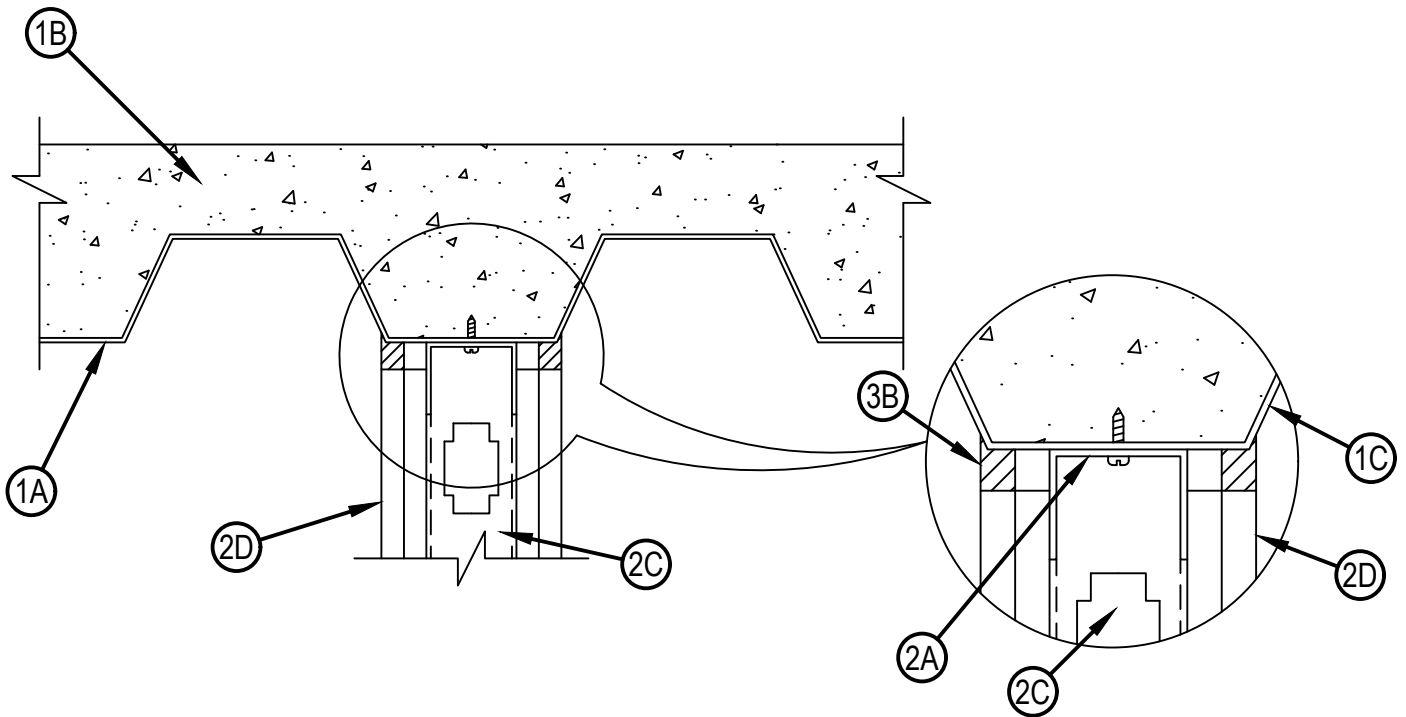

Reproduced by HILTI, Inc. Courtesy of
Underwriters Laboratories, Inc.
June 22, 2023

System No. HW-D-0084

HWD 0084

1. Floor Assembly — The fire-rated fluted steel floor unit/concrete assembly floor assembly shall be constructed of the materials and in the manner described in the individual D700 or D900 Series Floor-Ceiling Design in the Fire Resistance Directory and shall include the following construction features:
 - A. Steel Floor and Form Units* — Max 3 in. (76 mm) deep galv. steel fluted floor units.
 - B. Concrete — Min 2-1/2 in. (64 mm) thick reinforced concrete, as measured from the top plane of the floor units.
 - C. Spray-Applied Fire Resistive Materials — (Optional, Not Shown) — Prior to or after the installation of the ceiling runner and Fill, Void or Cavity Materials (Item 3), the steel floor units may be sprayed with a min 5/16 in. (8 mm) thickness to a max 11/16 in. (17 mm) thickness of fire resistive material.
 - GCP APPLIED TECHNOLOGIES INC — Type MK-6/HY
- 1A. Roof Assembly — (Not Shown) — As an alternate to the floor assembly, a fire rated fluted steel deck roof assembly may be used. The roof assembly shall be constructed of the materials and in the manner described in the individual P900 Series Roof-Ceiling Design in the UL Fire Resistance Directory. The hourly rating of the roof assembly shall be equal to or greater than the hourly rating of the wall assembly. The roof assembly shall include the following construction features:
 - A. Steel Roof Deck — Max 3 in. (76 mm) deep galv steel fluted roof deck.
 - B. Roof Insulation — Min 2-1/4 in. (57 mm) thick poured insulating concrete, as measured from the top plane of the floor units.
- 1B. Roof Assembly — As an alternate to Items 1 and 1A, a fire rated protected fluted steel deck roof assembly may be used. The roof assembly shall be constructed of the materials and in the manner described in the individual P700 Series Roof-Ceiling Design in the UL Fire Resistance Directory. The hourly rating of the roof assembly shall be equal to or greater than the hourly rating of the wall assembly. The roof assembly shall include the following construction features:
 - A. Steel Roof Deck — Max 3 in. (76 mm) deep galv steel fluted roof deck.
 - B. Spray—Applied Fire Resistive Materials* — (Not Shown)—Prior to or after the installation of the steel ceiling runners, Forming Material and Fill, Void or Cavity Material (Items 2A, 3A, 3B), the roof assembly shall be sprayed with the type and thickness of fire resistive material indicated in the individual P700 Series design.
2. Wall Assembly — The 1 or 2 h fire-rated gypsum board /steel stud wall assembly shall be constructed of the materials and in the manner specified in the individual U400 or V400 Series Wall and Partition Design in the UL Fire Resistance Directory and shall include the following construction features:
 - A. Steel Floor and Ceiling Runners — Floor and ceiling runners of wall assembly shall consist of min No. 25 gauge galv steel channels sized to accommodate steel studs (Item 2C). Ceiling runner to be provided with min. 2 in. (51 mm) flanges. Ceiling runner installed parallel to direction of fluted steel deck, centered beneath valley, and secured with steel masonry anchors, steel fasteners or welds spaced 24 in. (610 mm) OC. before or after optional spray-applied fire resistive material is used. The use of welds to secure the ceiling runner may only be used prior to the installation of the optional spray-applied material.
 - A1. Light Gauge Framing*-Slotted Ceiling Runner — As an alternate to the ceiling runner in Item 2A, slotted ceiling runner to consist of galv steel channel with slotted flanges sized to accommodate steel studs (Item 2C). Slotted ceiling runner installed parallel to direction of fluted steel deck, centered beneath valley, secured with steel masonry anchors, steel fasteners or welds spaced 24 in. (610 mm) OC. before or after optional spray-applied fire resistive material is used. The use of welds to secure the ceiling runner may only be used prior to the installation of the optional spray-applied material.

BRADY CONSTRUCTION INNOVATIONS INC, DBA SLIPTRACK SYSTEMS — SLP-TRK
CEMCO, LLC — CST
CLARKDIETRICH BUILDING SYSTEMS — Type SLT, SLT-H
MARINO/WARE, DIV OF WARE INDUSTRIES INC — Type SLT
METAL-LITE INC — The System
RAM SALES L L C — RAM Slotted Track
SCAFCO STEEL STUD MANUFACTURING CO
TELLING INDUSTRIES L L C — True-Action Deflection Track

A2. Light Gauge Framing* - Vertical Deflection Ceiling Runner — As an alternate to the ceiling runners in Items 2A and 2A1, vertical deflection ceiling runner to consist of galv steel channel with slotted vertical deflection clips mechanically fastened within runner. Slotted clips, provided with step bushings, for permanent fastening of steel studs. Flanges sized to accommodate steel studs (Item 2C). Vertical deflection ceiling runner installed parallel to direction of fluted steel deck, centered beneath valley, and secured with steel masonry anchors, steel fasteners or welds spaced 24 in. (610 mm) OC. before or after optional spray-applied fire resistive material is used. The use of welds to secure the ceiling runner may only be used prior to the installation of the optional spray-applied material.

THE STEEL NETWORK INC — VertiTrack VTD250, VTD362, VTD400, VTD600 and VTD800

A3. Light Gauge Framing* - Notched Ceiling Runner — As an alternate to the ceiling runners in Items 2A through 2A3, notched ceiling runners to consist of C-shaped galv steel channel with notched return flanges sized to accommodate steel studs (Item 2C). Notched ceiling runner installed parallel to direction of fluted steel deck, centered beneath valley, and secured with steel masonry anchors, steel fasteners or welds spaced 24 in. (610 mm) OC. before or after optional spray-applied fire resistive material is used. The use of welds to secure the ceiling runner may only be used prior to the installation of the optional spray-applied material.

OLMAR SUPPLY INC — Type SCR

B. Steel Attachment Clips — (Optional - Not Shown) - When spray applied fireproofing is used ceiling runner may be secured to deck with Z-shaped clips formed from min. 1 in. (25 mm) long strips of min 20 ga galv steel. Length of clips should not exceed the width (thickness) of the wall. Clips to be sized to extend through the thickness of the spray-applied fire-resistive material on the bottom of the steel deck with 1-1/2 or 2 in. (38 or 51 mm) long upper and lower legs. Legs of clips fastened to valleys of steel deck (prior to application of spray-applied fire-resistive materials) and top of ceiling runner with masonry anchors, steel fasteners or welds. Clips spaced max 24 in. (610 mm) OC.

C. Studs — Steel studs to be min 2-1/2 in. (64 mm) wide. Studs cut 1/2 to 3/4 in. (13 to 19 mm) less in length than assembly height with bottom nesting in and resting on floor runner and with top nesting in ceiling runner without attachment. When slotted ceiling runner (Item 2A1) is used, steel studs secured to slotted ceiling runner with No. 8 by 1/2 in. (13 mm) long wafer head steel screws at midheight of slot on each side of wall. Stud spacing not to exceed 24 in. (610 mm) OC. When vertical deflection ceiling runner (Item 2A2) is used, steel studs secured to slotted vertical deflection clips, through the bushings, with steel screws at midheight of each slot. Stud spacing not to exceed 24 in. (610 mm) OC.

D. Gypsum Board* — Gypsum board installed to a min total thickness 5/8 or 1-1/4 in. (16 or 32 mm) on each side of wall, for 1 or 2 hr fire resistance rated walls, respectively. Wall to be constructed as specified in the individual U400 or V400 Series Design in the UL Fire Resistance Directory, except that a max 3/4 in. (19 mm) gap shall be maintained between the top of gypsum board and bottom of steel deck. The screws attaching the gypsum board to the studs at the top of the first layer shall be located 4 in. (102 mm) from the steel deck valleys. The screws attaching the second layer to the steel studs shall be installed into the studs 3-1/2 in. (89 mm) below the valleys of the steel deck. The hourly fire rating of the joint system is dependent on the hourly ratings of the walls.

3. Fill, Void or Cavity Material* - Sealant — Max separation between the bottom of floor or roof and top of wall is 3/4 in. (19 mm). The joint system is designed to accommodate a max 33 percent compression or extension from its installed width. Fill material installed on each side of wall between the top of the gypsum board and the bottom of the steel deck. Min 5/8 in. (16 mm) thickness plus a 1/4 in. (6 mm) crown required for 1 hr fire rated system. Min 1-1/4 in. (32 mm) thickness installed flush with surface of wall required for 2 Hr fire rated system.

HILTI CONSTRUCTION CHEMICALS, DIV OF HILTI INC — CP601S Elastomeric Firestop Sealant or CFS-S SIL GG Sealant

* Indicates such products shall bear the UL or cUL Certification Mark for jurisdictions employing the UL or cUL Certification (such as Canada), respectively.

