



Classified by
Underwriters Laboratories, Inc.
to UL 2079 and CAN/ULC-S115

System No. HW-D-0342

HWD 0342

ANSI/UL2079	CAN/ULC S115
Assembly Rating — 2 Hr	F Rating — 2 Hr
Nominal Joint Width - 1 In.	FT Rating — 2 Hr
Class II Movement Capabilities — 8% Compression and Extension	FH Rating — 2 Hr
L Rating At Ambient — Less Than 1 CFM/lin ft	FTH Rating — 2 Hr
L Rating At 400°F — Less Than 1 CFM/lin ft	Nominal Joint Width - 1 In.
	Class II Movement Capabilities — 8% Compression and Extension
	L Rating At Ambient — Less Than 1 CFM/lin ft
	L Rating At 400°F — Less Than 1 CFM/lin ft

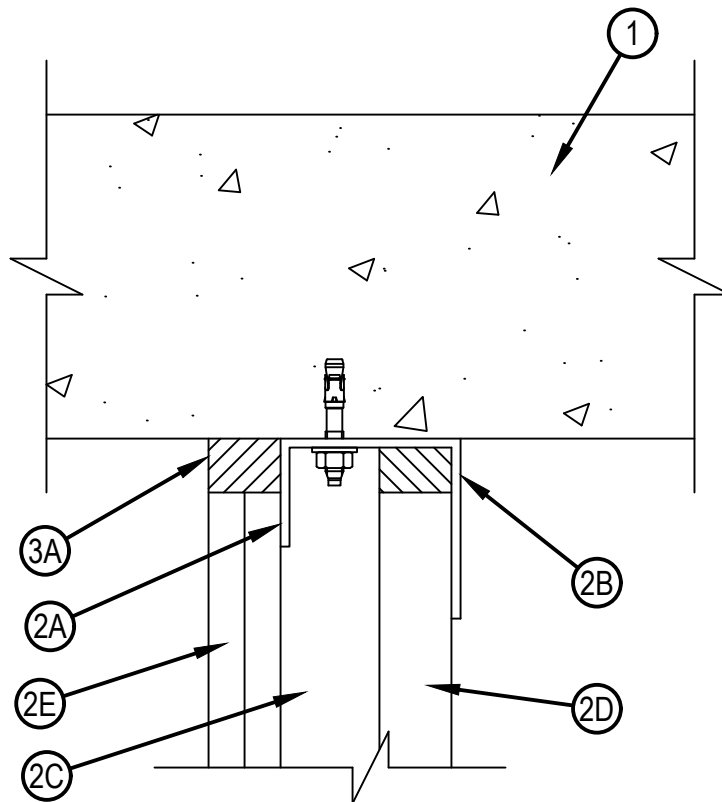

Reproduced by HILTI, Inc. Courtesy of
Underwriters Laboratories, Inc.
June 27, 2023

1. Floor Assembly — Min 2-1/2 in. (64 mm) thick reinforced lightweight or normal weight (100-150 pcf or 1600-2400 kg/m³) structural concrete. Floor may also be constructed of any 6 in. (152 mm) thick UL Classified hollow-core Precast Concrete Units*. See Precast Concrete Units category in the Fire Resistance Directory for names of manufactures.
2. Shaft Wall Assembly — The 2 hr fire-rated gypsum board /steel stud shaft wall assembly shall be constructed of the materials and in the manner described in the individual U400, V400 or W400 Series Wall and Partition Design in the UL Fire Resistance Directory and shall include the following construction features:
 - A. Floor and Ceiling Runners — J-shaped runner, 2-1/2 in. (64 mm) wide with unequal legs of min 1-1/4 in. (32 mm) and 2 in. (51 mm), fabricated from min 24 MSG galv steel. Runners positioned with short leg toward finished side of wall. Runners attached to structural supports with steel fasteners located not greater than 2 in. (51 mm) from ends and not greater than 24 in. (610 mm) OC.
 - B. Light Gauge Framing* - Slotted Ceiling Track — (Optional) Slotted ceiling track shall consist of galv steel channels with slotted flanges. Slotted ceiling track sized to accommodate steel "C-H" studs (Items 2C). Attached to concrete at ceiling with steel fasteners spaced max 24 in. (610 mm) OC.
CEMCO, LLC — CST
BRADY CONSTRUCTION INNOVATIONS INC, DBA SLIPTRACK SYSTEMS — SLP-TRK
MARINO/WARE, DIV OF WARE INDUSTRIES INC — Type SLT
 - B1. Light Gauge Framing Members* — (Optional Not Shown) - As an option, the steel studs (Item 2C) may incorporate vertical deflection clips for attachment to the ceiling runner (Item 2A) in accordance with the manufacturer's instructions.
THE STEEL NETWORK INC — VertiClip SLD 150.
 - C. Steel Studs — C-H-shaped studs, 2-1/2 in. (64 mm) wide by 1-1/2 in. (38 mm) deep, fabricated from min 25 MSG galv steel, cut to lengths 3/8 to 1/2 in. (10 to 13 mm) less than floor to ceiling height and spaced 24 in. (610 mm) OC. Studs nest in floor runner at bottom and J runner or slotted ceiling track at top. After installation of gypsum board liner panels (Item 2D), studs secured to flange of floor runner on finished side of wall only with No. 6 by 1/2 in. (13 mm) long self-drilling, self-tapping steel screws. Studs secured to flange of slotted ceiling track on finished side of wall only with No. 8 by 1/2 in. (13 mm) long self-drilling, self-tapping wafer head steel screws at slot midheight.
 - D. Gypsum Board* — 1 in. (25 mm) thick by 24 in. (610 mm) wide gypsum board liner panels as specified in the individual U400 or V400-Series design. Panels cut 1 in. (25 mm) less in length than floor to ceiling height. Vertical edges inserted in "H"-shaped section of "C-H" studs. At the ends of the assembly, the free edge of the end panels are attached to the long leg of vertical J-runners (Item 2A) with 1-5/8 in. (41 mm) long Type S steel screws spaced max 12 in. (305 mm) OC.
 - E. Gypsum Board* — Gypsum board sheets, 1/2 or 5/8 in. (13 or 16 mm) thick, applied vertically or horizontally in two layers on finished side of wall as specified in the individual U400 or V400-Series design. A max 1 in. (25 mm) gap shall be maintained between the top of the gypsum board and the bottom surface of the concrete floor. The screws attaching the gypsum board layers to the C-H studs shall be located 1 in. (25 mm) below the bottom of the J-runner or slotted ceiling track. No gypsum board attachment screws are to penetrate the ceiling J-runner and slotted ceiling track.
3. Joint System — Max separation between top of liner panel (Item 2D) and between top of gypsum board sheets (Item 2E) at time of installation of joint system is 1 in. (25 mm). The joint system is designed to accommodate a maximum 8 percent compression and extension from its installed width. The joint system consists of the following:
 - A. Fill, Void or Cavity Material* - Sealant — Min 1 in. (25 mm) depth of sealant to be installed to fill linear gap between top of gypsum board liner panel (Item 2D) and top inside surface of ceiling J-runner or slotted ceiling track prior to installation of gypsum board (Item 2E) on finished side of wall. Min 1 in. (25 mm) depth of sealant to be installed to fill linear gap between top of gypsum board sheets (Item 2E) and bottom of concrete floor.
HILTI CONSTRUCTION CHEMICALS, DIV OF HILTI INC — CP 606, CFS-S SIL GG

* Indicates such products shall bear the UL or cUL Certification Mark for jurisdictions employing the UL or cUL Certification (such as Canada), respectively.

