



Classified by  
Underwriters Laboratories, Inc.  
to UL 2079 and CAN/ULC-S115

# System No. HW-D-0528

HW-D-0528

ANSI/UL2079	CAN/ULC S115
Assembly Rating — 1 Hr (See Item 2)	F Rating — 1 Hr
Nominal Joint Width - 2 In.	FT Rating — 1 Hr
Class II Movement Capabilities - 100% Compression or Extension	FH Rating — 1 Hr
	FTH Rating — 1 Hr
	Nominal Joint Width - 2 In.
	Class II and III Movement Capabilities — 100% Compression or Extension

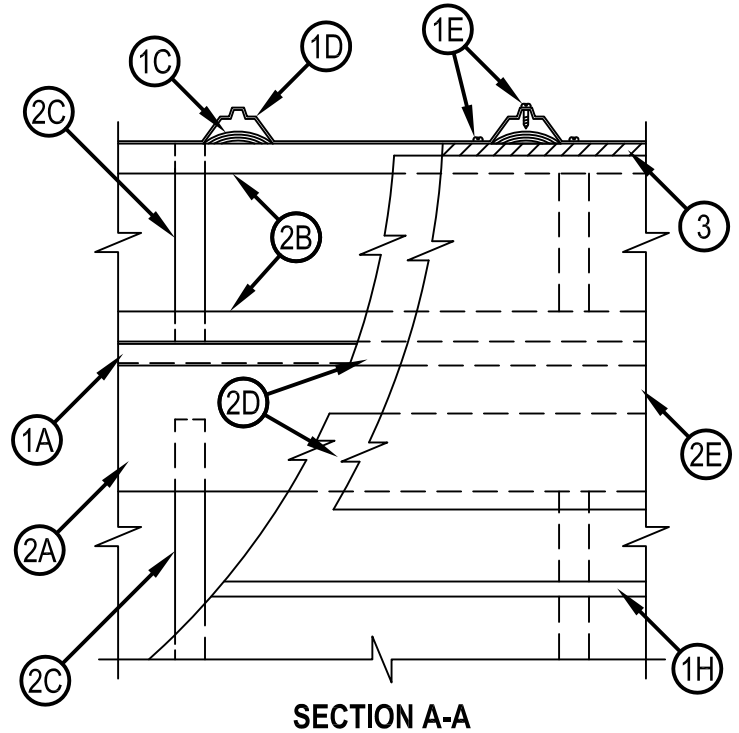
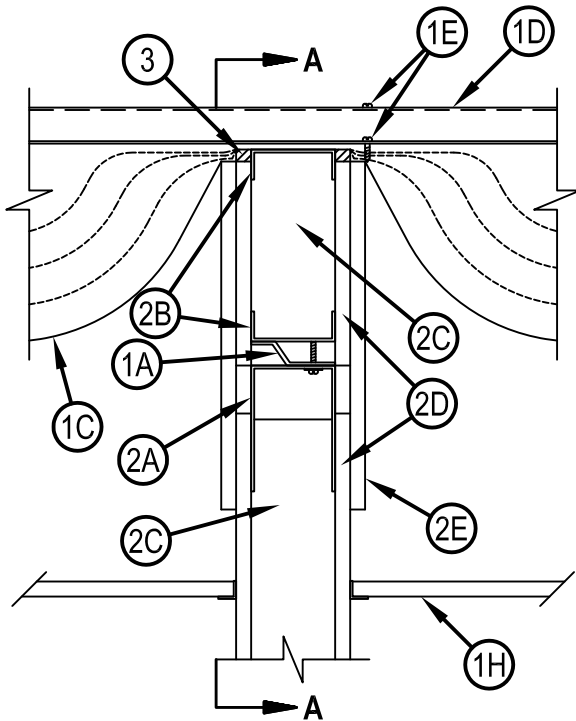

1. Roof-Ceiling Assembly — The fire rated roof-ceiling assembly shall be constructed of the materials and in the manner described in the individual P200 or P500 Series Roof-Ceiling Designs in the UL Fire Resistance Directory and shall include the following construction features:

- A. Purlin — Min 16 ga coated steel. Max spacing as specified in the individual Roof-Ceiling Design.
- B. Lateral Bracing — (Not Shown) - As required.
- C. Batts and Blankets\* - Insulation — Any faced compressible glass-fiber blanket insulation having a min 6 in. (152 mm) thickness before compression and a min density of 0.6 pcf (9.6 kg/m<sup>3</sup>). Insulation draped over purlins prior to installation of panel clips (Item 1F) and/or metal roof deck panels (Item 1D). Side edges of the batts shall be butted or overlapped a max of 3 in. (76 mm). See Batts and Blankets (BZJZ) category in the UL Fire Resistance Directory or Batts and Blankets (BKNV) category in the UL Building Materials Directory for names of manufacturers.
- D. Metal Roof Deck Panels\* — Min 26 ga coated steel. Panels continuous over two or more spans. Roof panel end laps, if required, centered over purlins with min 3 in. (76 mm) panel overlap as specified in the individual Roof-Ceiling Design. A line of tube sealant or tape sealant may be used at panel end and side laps. See Metal Roof Deck Panels (TJPV) category in the UL Roofing Materials and Systems Directory for names of manufacturers.
- E. Fasteners — Fasteners used for panel-to-purlin and panel-to-panel connections to be self-tapping, hex-head, plated steel or stainless steel screws with either an integral or a separate steel washer fitted with a compressible sealing washer. Fastener type, length, pilot hole diam and spacing to be as specified in the individual Roof-Ceiling Design.

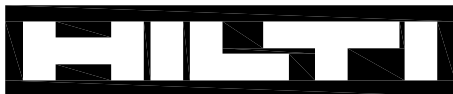

**Hilti Firestop Systems**

Reproduced by HILTI, Inc. Courtesy of  
Underwriters Laboratories, Inc.  
January 28, 2015

- F. Roof Deck Fasteners\* - Panel Clips — (Not Shown) - Panel clips used for panel-to-purlin connections to be secured to purlin through insulation as specified in the individual Roof-Ceiling Design.  
See Roof Deck Fasteners (TLSX) category in the UL Roofing Materials and Systems Directory for names of manufacturers.
- G. Thermal Spacer Blocks — (Not Shown) - Expanded polystyrene strips cut to fit between panel clips (Item 1F) as specified in the individual Roof-Ceiling Design. Thermal spacer blocks, when used, are to be installed between insulation (Item 1C) and metal roof deck panels (Item 1D) over purlins.
- H. Ceiling Membrane — The Steel Framing Members\*, Acoustical Material\*, Gypsum Board\* and other ceiling membrane components shall be as specified in the individual Roof-Ceiling Design.
2. Wall Assembly — The 1 h fire-rated gypsum board/steel stud wall assembly shall be constructed of the materials and in the manner specified in the individual U400 or V400 Series Wall and Partition Design in the UL Fire Resistance Directory and shall include the following construction features:
- A. Ceiling Deflection Channel — U-shaped channel formed from min 16 ga steel sized to accommodate steel studs (Item 2C) and provided with 5 in. (127 mm) flanges. Deflection channel installed parallel with and aligned with web of purlin and secured to bottom flange of purlin with min No. 14 self-tapping, hex-head, plated steel or stainless steel screws spaced max 24 in. (610 mm) OC.
- B. Steel Floor and Ceiling Runners — Floor runner of the wall assembly and the floor and ceiling runners of the cripple wall above the wall assembly shall consist of min 1-1/4 in. (32 mm) deep min 25 ga galv steel channels sized to accommodate steel studs (Item 2C). Floor runner of cripple wall aligned with and resting atop flange of purlin. Ceiling runner of cripple wall installed to compress insulation (Item 1C) to min thickness of 3/8 in. (10 mm) by wedging lengths of stud (Item 2C) between the runners. Steel studs of cripple wall attached to web of purlin with steel screws driven through opposite side of purlin web.
- C. Studs — Steel studs to be min 3-1/2 in. (89 mm) wide. Studs cut max 2 in. (51 mm) less in length than assembly height with bottom nesting in and resting on the floor runner and with top nesting in ceiling deflection channel without attachment. Width of stud to be equal to or greater than width of purlin flange. Stud spacing not to exceed 24 in. (610 mm) O.C. Studs of cripple wall cut to length as required to compress insulation (Item 1C) to min thickness of 3/8 in. (10 mm) and spaced max 24 in. (610 mm) OC.
- D. Gypsum Board\* — Min 5/8 in. (16 mm) thick gypsum board sheets installed on each side of wall. Wall to be constructed as specified in the individual U400 or V400 Series Design in the UL Fire Resistance Directory except that a max 2 in. wide gap shall be maintained between the gypsum board of the wall assembly below the purlin and the gypsum board of the cripple wall. Top edge of gypsum board of wall assembly to be max 2 in. (51 mm) below top of ceiling deflection channel. Bottom edge of gypsum board of cripple wall to be flush with top of ceiling deflection channel. Screws securing gypsum board to steel studs of wall assembly to be located 2-1/4 in. to 2-1/2 in. (57 to 64 mm) below flange of ceiling deflection channel. Screws securing gypsum board of cripple wall to be driven into web of purlin and into studs and runners of cripple wall. No screws are to be driven into flanges of ceiling deflection channel.
- E. Gypsum Board\* — Min 5/8 in. (16 mm) thick "rip strip" of gypsum board installed to cover first layer of gypsum board on cripple wall and to lap min 3 in. (76 mm) onto gypsum board of wall assembly on each side of wall. The "rip strip" of gypsum board is to be the same material used for the wall assembly and is to be secured to the web of purlin and into studs and runners of the cripple wall. No screws are to be driven into flanges of ceiling deflection channel. Joints of "rip strip" to be offset from joints of gypsum board on wall assembly.  
Max separation between top of wall assembly gypsum board and bottom of cripple wall gypsum board (at time of installation of joint system) is 2 in. (51 mm). The joint system is designed to accommodate a max 100 percent compression or extension from its installed width.
3. Fill, Void or Cavity Material\* — Sealant — Min 5/8 in. (16 mm) thickness of fill material installed to fill any gap between top of cripple wall gypsum board and insulation (Item 1C) or purlin flange on each side of the wall.  
HILTI CONSTRUCTION CHEMICALS, DIV OF HILTI INC — CP601S, CFS-S SIL GG, CP606, FS-ONE Sealant or FS-ONE MAX Intumescent Sealant.

\* Indicates such products shall bear the UL or cUL Certification Mark for jurisdictions employing the UL or cUL Certification (such as Canada), respectively.

