



Classified by
Underwriters Laboratories, Inc.
to UL 2079 and CAN/ULC-S115

System No. HW-D-0571

HWD 0571

ANSI/UL2079	CAN/ULC S115
Assembly Ratings — 1 and 2 Hr (See Item 2)	F Ratings — 1 and 2 Hr (See Item 2)
Nominal Joint Width - 1-1/2 In.	FT Ratings — 1 and 2 Hr (See Item 2)
Class II Movement Capabilities — 50% Compression and Extension	FH Ratings — 1 and 2 Hr (See Item 2)
L Rating At Ambient — Less Than 1 CFM/Lin Ft	FTH Ratings — 1 and 2 Hr (See Item 2)
L Rating At 400°F — Less Than 1 CFM/Lin Ft	Nominal Joint Width - 1-1/2 In.
	Class II Movement Capabilities — 50% Compression and Extension
	L Rating At Ambient — Less Than 1 CFM/Lin Ft
	L Rating At 400°F — Less Than 1 CFM/Lin Ft

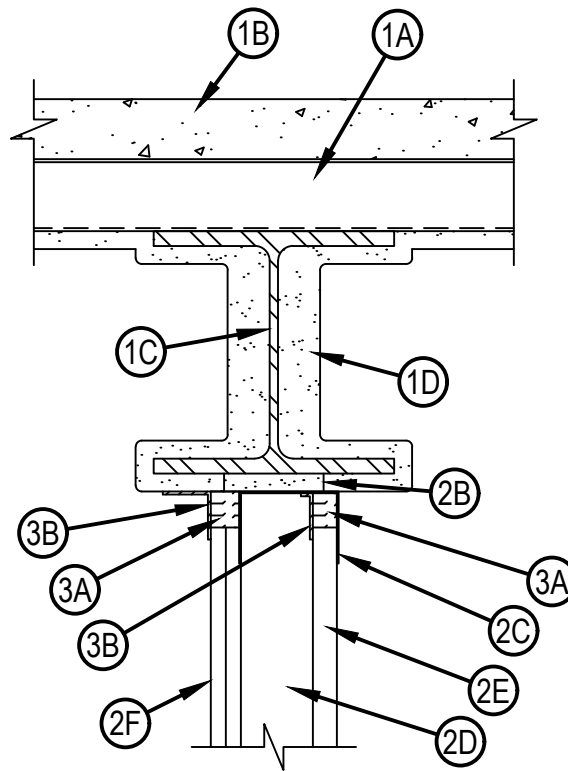

Reproduced by HILTI, Inc. Courtesy of
Underwriters Laboratories, Inc.
June 26, 2023

System No. HW-D-0571

HWD 0571

1. Floor Assembly — The fire-rated fluted steel deck/concrete floor assembly shall be constructed of the materials and in the manner described in the individual D700, D800 or D900 Series Floor-Ceiling Design in the UL Fire Resistance Directory and shall include the following construction features:
- A. Steel Floor And Floor Units* — Max 3 in. (76 mm) deep galv steel fluted floor units.
 - B. Concrete — Min 2-1/2 in. (64 mm) thick lightweight or normal weight (100-150 pcf or 1600-2400 kg/m³) concrete, as measured from the top plane of the floor units.
 - C. Structural Steel Support — Steel beam, as specified in the individual D700, D800, or D900 Series Floor-Ceiling Design, used to support steel floor units. Steel beam centered over and parallel with wall assembly.
 - D. Spray-Applied Fire Resistive Material* — After installation of the steel attachment clips (Item 2B), steel floor units and structural steel support to be sprayed with the min thickness of material specified in the individual D700, D800, or D900 Series Design. The flutes of the steel floor units are to be filled with material across the entire top flange of the steel beam. Additional material shall be applied to the web of the steel beam on each side of the wall. For a 1 hr Assembly Rating, the total thickness of material applied to each side of the steel beam web shall be 13/16 in. (21 mm). For a 2 hr Assembly Rating, the total thickness of material applied to each side of the steel beam web shall be 1-3/8 in. (35 mm).
- GCP APPLIED TECHNOLOGIES INC — Type MK-6/HY, MK-10HB
- D1. Spray-Applied Fire Resistive Material* — After installation of the steel attachment clips (Item 2B), steel floor units and structural steel support to be sprayed with the min thickness of material specified in the individual D700, D800, or D900 Series Design. The flutes of the steel floor units are to be filled with material across the entire top flange of the steel beam. Additional material shall be applied to the web of the steel beam on each side of the wall. For a 1 hr Assembly Rating, the total thickness of material applied to each side of the steel beam web shall be 11/16 in. (18 mm). For a 2 hr Assembly Rating, the total thickness of material applied to each side of the steel beam web shall be 1-1/2 in. (38 mm).
- ISOLATEK INTERNATIONAL — Type 300, Type 400, Type II
- 1A. Roof Assembly — As an alternate to the floor assembly, a fire rated fluted steel deck roof assembly may be used. The roof assembly shall be constructed of the materials and in the manner described in the individual P700 or P900 Series Roof-Ceiling Design in the UL Fire Resistance Directory. The hourly rating of the roof assembly shall be equal to or greater than the hourly rating of the wall assembly. The roof assembly shall include the following construction features as applicable:
- A. Steel Roof Deck — Max 3 in. (76 mm) deep galv steel fluted roof deck.
 - B. Roof Insulation — Min 2-1/4 in. (57 mm) thick poured insulating concrete, as measured from the top plane of the steel roof deck.
 - C. Structural Steel Support — Steel beam, as specified in the individual Roof-Ceiling Design, used to support steel roof deck. Steel beam centered over and parallel with wall assembly.
 - D. Spray-Applied Fire Resistive Material* — After installation of the steel attachment clips (Item 2B), steel roof deck (P700 series) and structural steel support to be sprayed with the min thickness of material specified in the individual Roof-Ceiling Design. In addition, the flutes of the steel deck are to be filled with material across the entire top flange of the steel beam. Additional material shall be applied to the web of the steel beam on each side of the wall. For a 1 hr Assembly Rating, the total thickness of material applied to each side of the steel beam web shall be 13/16 in. (21 mm). For a 2 hr Assembly Rating, the total thickness of material applied to each side of the steel beam web shall be 1-3/8 in. (35 mm).
- GCP APPLIED TECHNOLOGIES INC — Type MK-6/HY, MK-10HB
- D1. Spray-Applied Fire Resistive Material* — After installation of the steel attachment clips (Item 2B), roof deck (P700 series) and structural steel support to be sprayed with the min thickness of material specified in the individual Roof-Ceiling Design. In addition, the flutes of the roof deck are to be filled with material across the entire top flange of the steel beam on each side of the wall. For a 1 hr Assembly Rating, the total thickness of material applied to each side of the steel beam web shall be 11/16 in. (18 mm). For a 2 hr Assembly Rating, the total thickness of material applied to each side of the steel beam web shall be 1-1/2 in. (38 mm).
- ISOLATEK INTERNATIONAL — Type 300, Type 400 or Type II



Hilti Firestop Systems

Reproduced by HILTI, Inc. Courtesy of
Underwriters Laboratories, Inc.
June 26, 2023

2. Shaft Wall Assembly — The 1 hr or 2 hr fire rated gypsum board/steel stud shaft wall assembly shall be constructed of the materials and in the manner described in the individual U400 or V400 Series Wall and Partition Design in the UL Fire Resistance Directory and shall include the following construction features:

- A. Floor and Wall Runners — (Not Shown) - J-shaped runner, sized equal in width to steel studs (Item 2C), with unequal legs of 1 in. (25 mm) and 2 in. (51 mm), fabricated from 24 MSG galv steel. Runners positioned with short leg toward finished side of wall. Runners attached to floor with steel fasteners located not greater than 2 in. (51 mm) from ends and not greater than 24 in. (610 mm) OC.
- B. Steel Attachment Clips — Z-shaped clips formed from min 1 in. (25 mm) wide strips of min 20 ga galv steel. Length of clips should not exceed the width (thickness) of the wall. Clips to be sized to extend through the thickness of the spray-applied fire-resistive material on the bottom flange of the steel beam with 2 in. (51 mm) long upper and lower legs. Height of clips to be equal to the required thickness of spray-applied fireproofing material (Item 1D or 1D1) on the bottom flange of the steel beam. Legs of clips fastened to bottom of beam (prior to application of spray-applied fire-resistive materials) and top of ceiling runner with steel fasteners or welds. Clips spaced max 24 in. (610 mm) OC.
- C. Ceiling Runner — Ceiling runner of wall assembly shall consist of galv steel channel sized to accommodate steel studs (Item 2D). Flange height of ceiling runner shall be min 1/4 in. (6 mm) greater than max extended joint width. Ceiling runner to be positioned beneath and parallel with bottom flange of steel beam. Ceiling runner secured to steel attachment clips (Item 2B) with steel fasteners or welds spaced max 24 in. (610 mm) OC.
 - C1. Light Gauge Framing* - Slotted Ceiling Runner — As an alternate to the ceiling runner in Item 2B, slotted ceiling runner to consist of galv steel channel with slotted flanges sized to accommodate steel studs (Item 2C). Flange height of slotted ceiling runner shall be min 1/4 in. (6 mm) greater than max extended joint width. Slotted ceiling runner to be positioned beneath and parallel with bottom flange of steel beam. Slotted ceiling runner secured to steel attachment clips (Item 2B) with steel fasteners or welds spaced max 24 in. (610 mm) OC.
 - BRADY CONSTRUCTION INNOVATIONS INC, DBA SLIPTRACK SYSTEMS — SLP-TRK, SLPTRK325
 - CEMCO, LLC — CST
 - CLARKDIETRICH BUILDING SYSTEMS — Type SLT, SLT-H
 - MARINO/WARE, DIV OF WARE INDUSTRIES INC — Type SLT
 - METAL-LITE INC — The System
 - RAM SALES L L C — RAM Slotted Track
 - SCAFCO STEEL STUD MANUFACTURING CO — Slotted Track
 - TELLING INDUSTRIES L L C — True-Action Deflection Track
 - C2. Light Gauge Framing* — Slotted Ceiling Runner — As an alternate to the ceiling runner in Item 2C through 2C1, slotted ceiling runner to consist of galv steel channel, sized to accommodate steel studs (Item 2D). Flange height of slotted ceiling runner shall be 3-1/4 in. (83 mm) with 2 in. (51 mm) deep slots. Slotted ceiling runner to be positioned beneath and parallel with bottom flange of steel beam. Slotted ceiling runner secured to steel attachment clips (Item 2B) with steel fasteners or welds spaced max 24 in. (610 mm) OC.
 - SCAFCO STEEL STUD MANUFACTURING CO — Slotted Track-Type SDLT
- D. Steel Studs — C-H shaped studs, min 4 in. (102 mm) wide by 1-1/2 in. (38 mm) deep, fabricated from 25 MSG galv steel, cut to lengths 3/4 to 1 in. (19 to 25 mm) less than floor to ceiling height beneath coating on steel beam bottom flange and spaced 24 in. (610 mm) OC. When slotted ceiling runner specified in Item 2C2 is used the C-H-shaped studs cut in lengths 3/4 to 1-3/4 in. (19 to 44 mm) less than floor to ceiling height beneath coating on steel beam bottom flange and spaced 24 in. (610 mm) OC.
- E. Gypsum Board* — Nom 1 in. (25 mm) thick gypsum board liner panels. Panels cut 1-1/2 in. (38 mm) less in length than floor to ceiling height beneath coating on steel beam bottom flange. Vertical edges inserted in H-shaped section of C-H studs. At the ends of the assembly, the free edge of the end panels are attached to the long leg of vertical J-runners (Item 2A) with 1-5/8 in. (41 mm) long Type S steel screws spaced max 12 in. (305 mm) OC.
- F. Gypsum Board* — Nom 5/8 in. (16 mm) thick gypsum board applied vertically in one or two layers for 1 hr and 2 hr fire rated assemblies, respectively. Panels cut 1-1/2 in. (38 mm) less in length than floor to ceiling height beneath coating on steel beam bottom flange. The screws attaching the gypsum board layers to the C-H studs shall be located 1 to 1-1/2 in. (25 to 38 mm) below the bottom of the ceiling runner or slotted ceiling track. No gypsum board attachment screws are to penetrate the ceiling runner or slotted ceiling track.
 - The hourly ratings of the joint system are equal to the hourly fire rating of the wall.



System No. HW-D-0571

HW-D-0571

3. Joint System — Max separation between coating on steel beam bottom flange and top of gypsum board (at the time of installation of the joint system) is 1 1/2 in. (38 mm). The joint system is designed to accommodate a max 50 percent compression or extension from its installed width. The joint system consists of the following:

A. Forming Material* — Min 4 pcf (64 kg/m³) density mineral wool batt insulation cut to a thickness twice larger than the distance between the top of the gypsum board and the bottom of the coating on the steel beam bottom flange. Material compressed 50 percent and installed within ceiling runner above top of liner panel flush with the inside surface of the panel. Material compressed and installed on finished side of the wall between the top of the gypsum board and the bottom of the coating on the steel beam bottom flange, flush with the surface of the wall.

INDUSTRIAL INSULATION GROUP L L C — MinWool-1200 Safing

JOHNS MANVILLE — Safing

ROCK WOOL MANUFACTURING CO — Delta Board

ROCKWOOL — SAFE

THERMAFIBER INC — Type SAF

A1. Forming Material* - Strips — As an alternate to Item 2A, the strips are stacked to a height twice larger than the distance between the top of the gypsum board and the bottom of the coating on the steel beam bottom flange. Strips compressed 50 percent and installed within ceiling runner above top of liner panel flush with the inside surface of the panel. Strips compressed and installed on finished side of the wall between the top of the gypsum board and the bottom of the coating on the steel beam bottom flange, flush with the surface of the wall.

HILTI CONSTRUCTION CHEMICALS, DIV OF HILTI INC — CP 767 Speed Strips

B. Fill, Void or Cavity Material* — Min 1/16 in. (1.6 mm) dry thickness (1/8 in. or 3.2 mm wet thickness) of fill material sprayed or troweled within stud cavity and on finished side of the shaft wall to completely cover mineral wool forming material. Fill material to overlap a min of 1/2 in. (13 mm) onto gypsum board and ceiling runner within stud cavity. Fill material to overlap a min of 1/2 in. (13 mm) onto gypsum board and min 2 in. (51 mm) onto spray-applied fire resistive material (Item 1C) on the finished side of the wall.

HILTI CONSTRUCTION CHEMICALS, DIV OF HILTI INC — CFS-SP WB Firestop Joint Spray

* Indicates such products shall bear the UL or cUL Certification Mark for jurisdictions employing the UL or cUL Certification (such as Canada), respectively.



Hilti Firestop Systems

Reproduced by HILTI, Inc. Courtesy of
Underwriters Laboratories, Inc.
June 26, 2023